

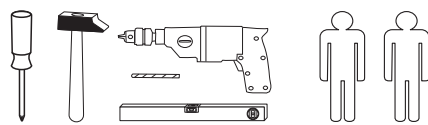

88844.327

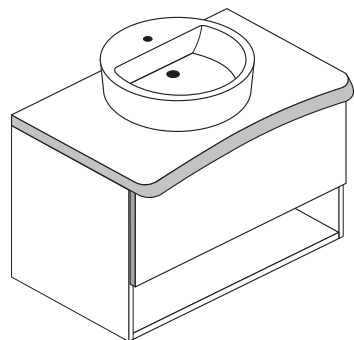

1 4 x 2802	2 4 x 2801	3 3,5 x 15 18 x 2804	4 8 x 30 8 x 2861	5 5,8 x 55 2 x 2840	6 8 x 30 2 x 2842
7 1 x 2881	8 1 x 2880	9 2 x 2865	10 Leim 1 x 2863	11 4 x 30 2 x 2830	12 4 x 2845
14 4 x 15 4 x 2810	15 21 x 25 mm 1 x 2529	16 3 x 13,5 4 x 1123	17 6,3 x 11 4 x 2815.1	18 6,3 x 16 8 x 2816	19 2 x 1121
20 1 x R 1 x L 5284.300	21 1 x R 1 x L 5285.300	22 2 x 1122	23 4 x 9 5 x 30 4 x 2 x		
24 Silikon 1 x 1970					

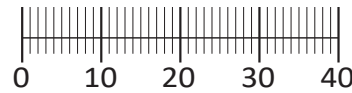

Das beigefügte Wandbefestigungsmaterial (Dübel und Schrauben) eignet sich nur für festes Mauerwerk (z.B.: Beton- oder Ziegelwände). Für andere Wandaufbauten sind eventuell Spezialdübel und andere Schrauben notwendig. Ziehen Sie gegebenenfalls eine Fachkraft zu Rate.

De begeleidende wandmontage hardware (pluggen en schroeven) is alleen geschikt voor massief metselwerk (bijvoorbeeld beton of bakstenen muren). Voor andere muur structuren zijn eventueel bijzondere ankerbouten en andere noodzakelijke. Draai indien nodig, een deskundige.

Приложенный материал для крепления к стене (дюбели и винты) пригоден только для жестких кладок (например, бетонные или кирпичные стены). Для других настенных конструкций необходимы смотря по обстоятельствам специальные дюбели и другие винты. При необходимости проконсультируйтесь у специалиста.

Le mur d'accompagnement matériel de montage (chevilles et les vis) ne convient que pour la maçonnerie solide (par exemple en béton ou des murs de briques). Pour les structures de mur d'autres sont peut-être spéciale boulons d'ancrage et d'autres nécessaires. Serrer le cas échéant, un expert.

Załączony materiał do mocowania do ściany (kolki rozprężne i wkręty) nadaje się tylko do ścian murowanych (np. z betonu lub cegiel). Do ścian wykonanych w innych technologiach konieczne być mogą specjalne kolki rozprężne i inne wkręty. W razie potrzeby skorzystaj z fachowej pomocy

Il muro di accompagnamento hardware di montaggio (tasselli e viti) è'e adatto solo per muratura piena (ad esempio calcestruzzo o muratura). Per le altre strutture murarie sono forse speciali bulloni di ancoraggio e necessari di altri. Serrare se necessario, un esperto.

The accompanying wall mounting hardware (anchors and screws) is suitable only for solid masonry (eg concrete or brick walls). For other wall structures are possibly special anchor bolts and other necessary. Tighten if necessary, an expert.

Ekteki duvara sabit montaj malzemeleri (dübel ve vidalar), sadece sağlam duvarlar için (örnek: beton veya tuğla) elverişlidir. Başka duvarlar için özel dübeller ve farklı vidalar gerekebilir. Gerektiğinde bir uzmana danışınız.

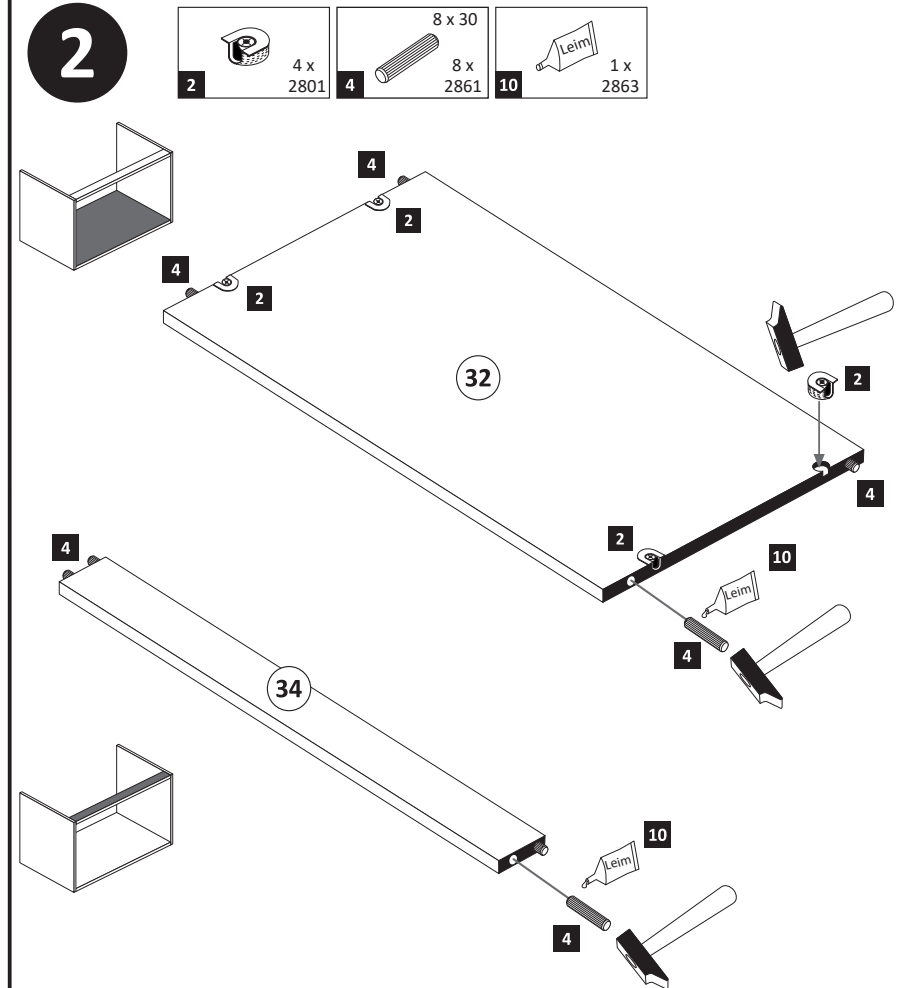
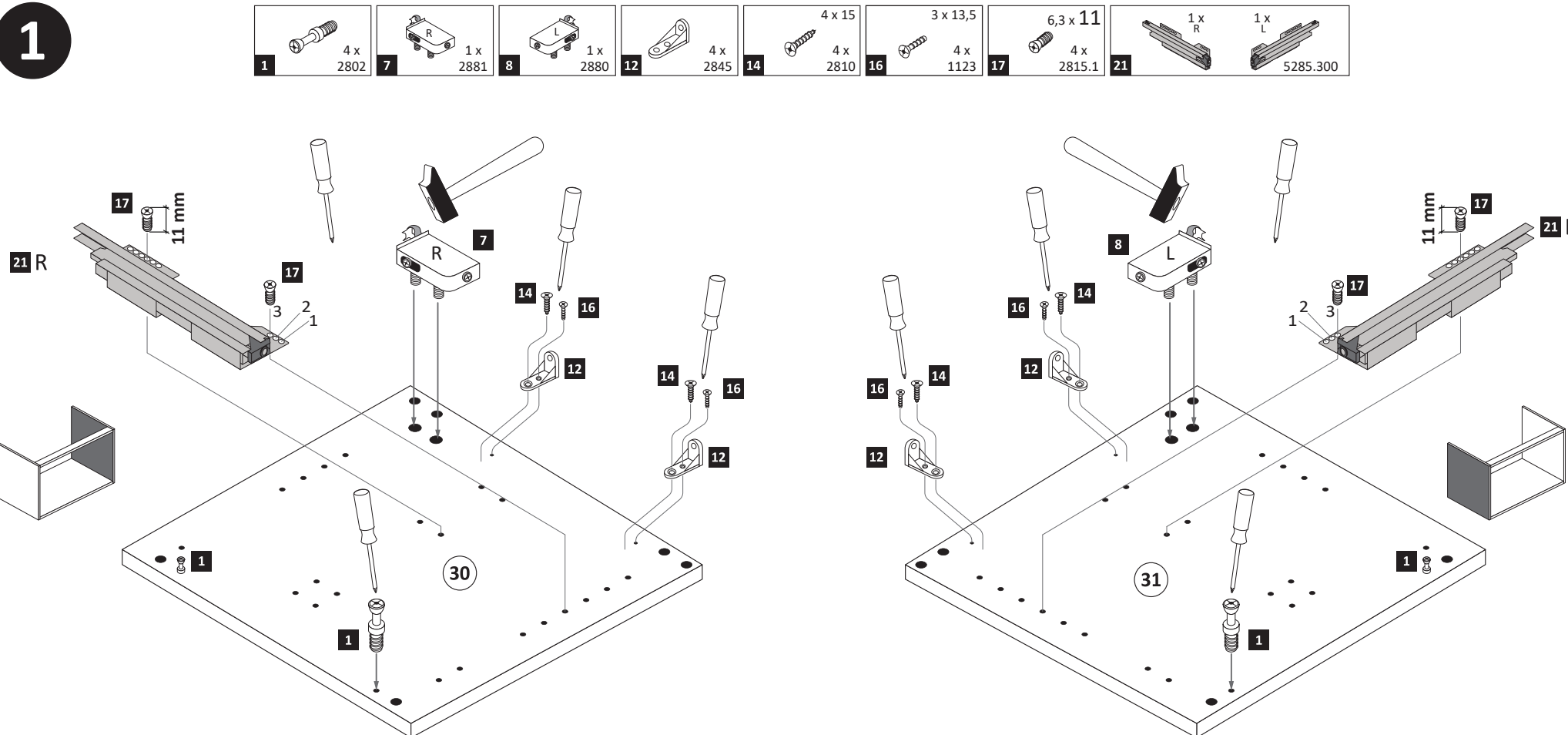
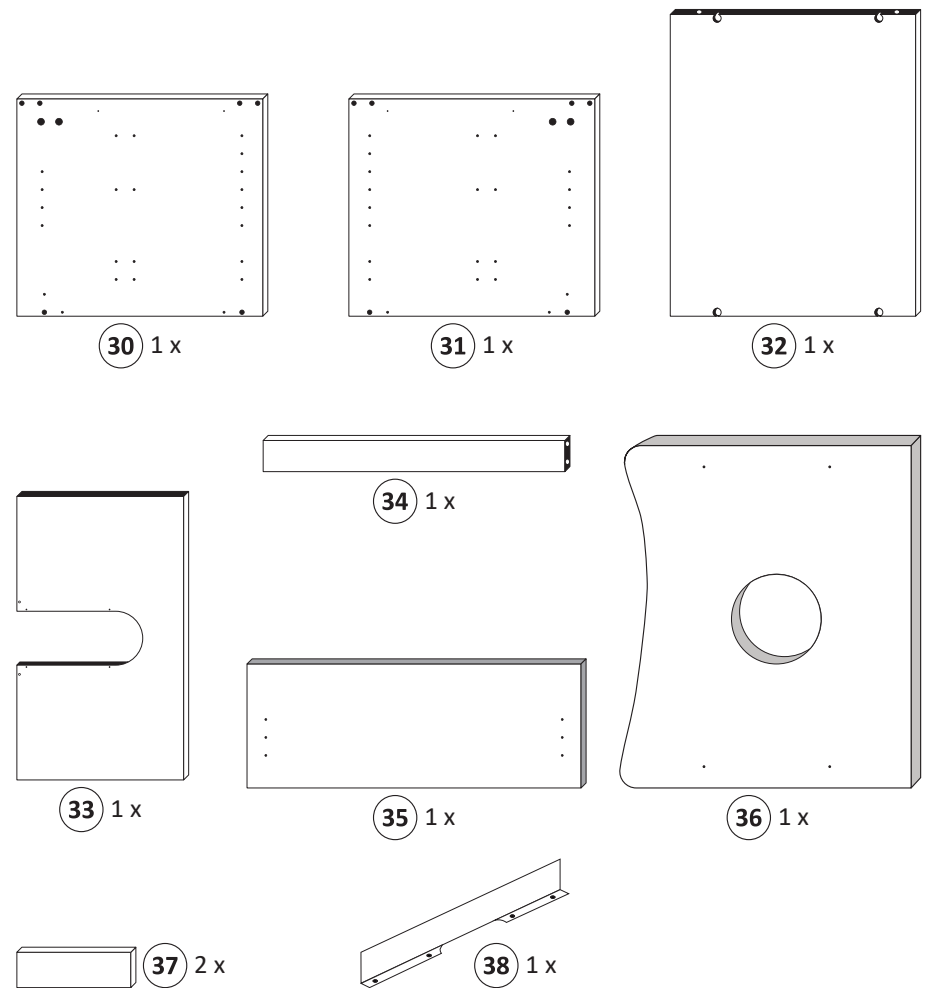

3

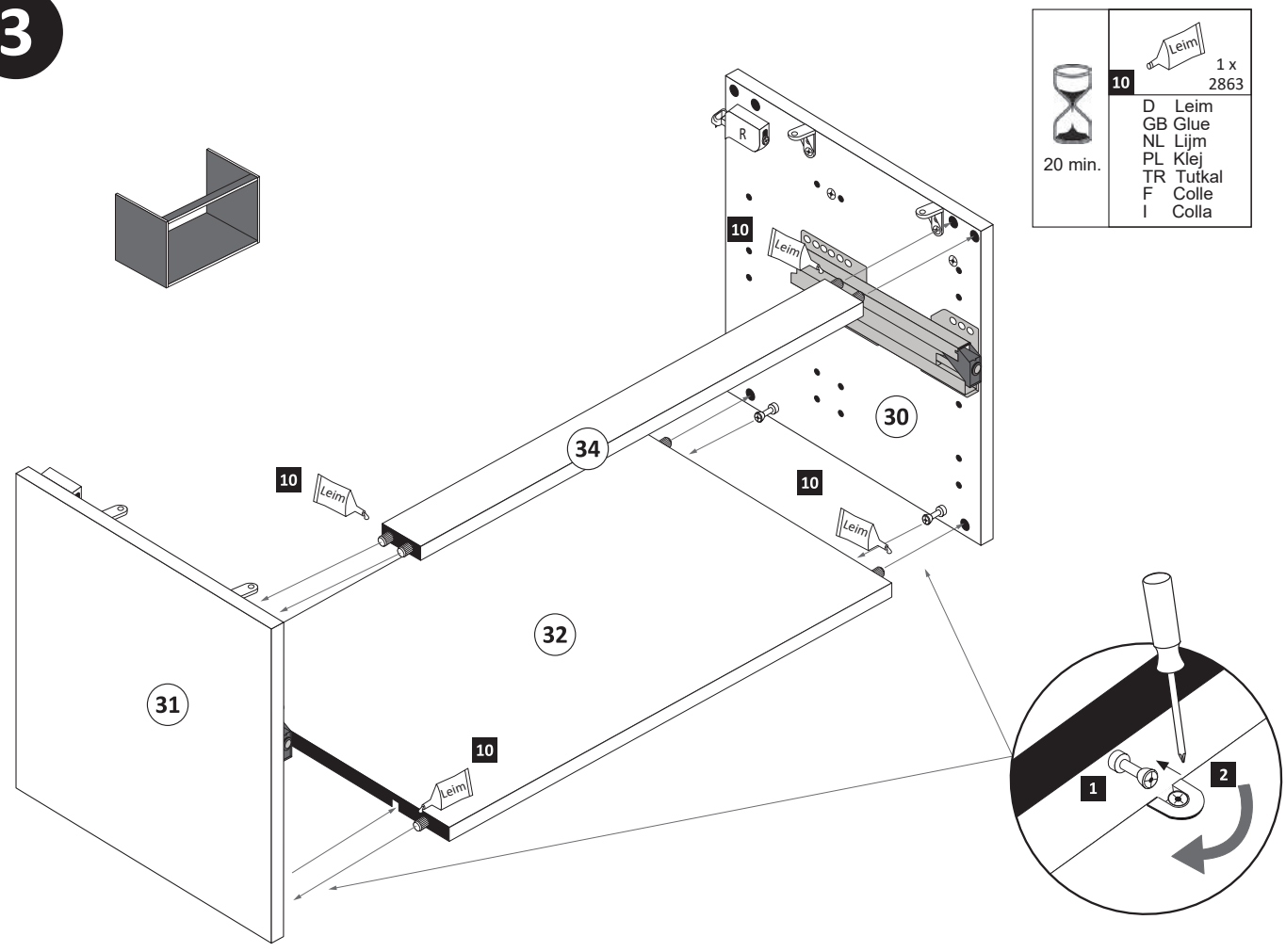

	20 min.
	1 x 2863
	D Leim
	GB Glue
	NL Lijm
	PL Klej
	TR Tutkal
	F Colle
	I Colla

4

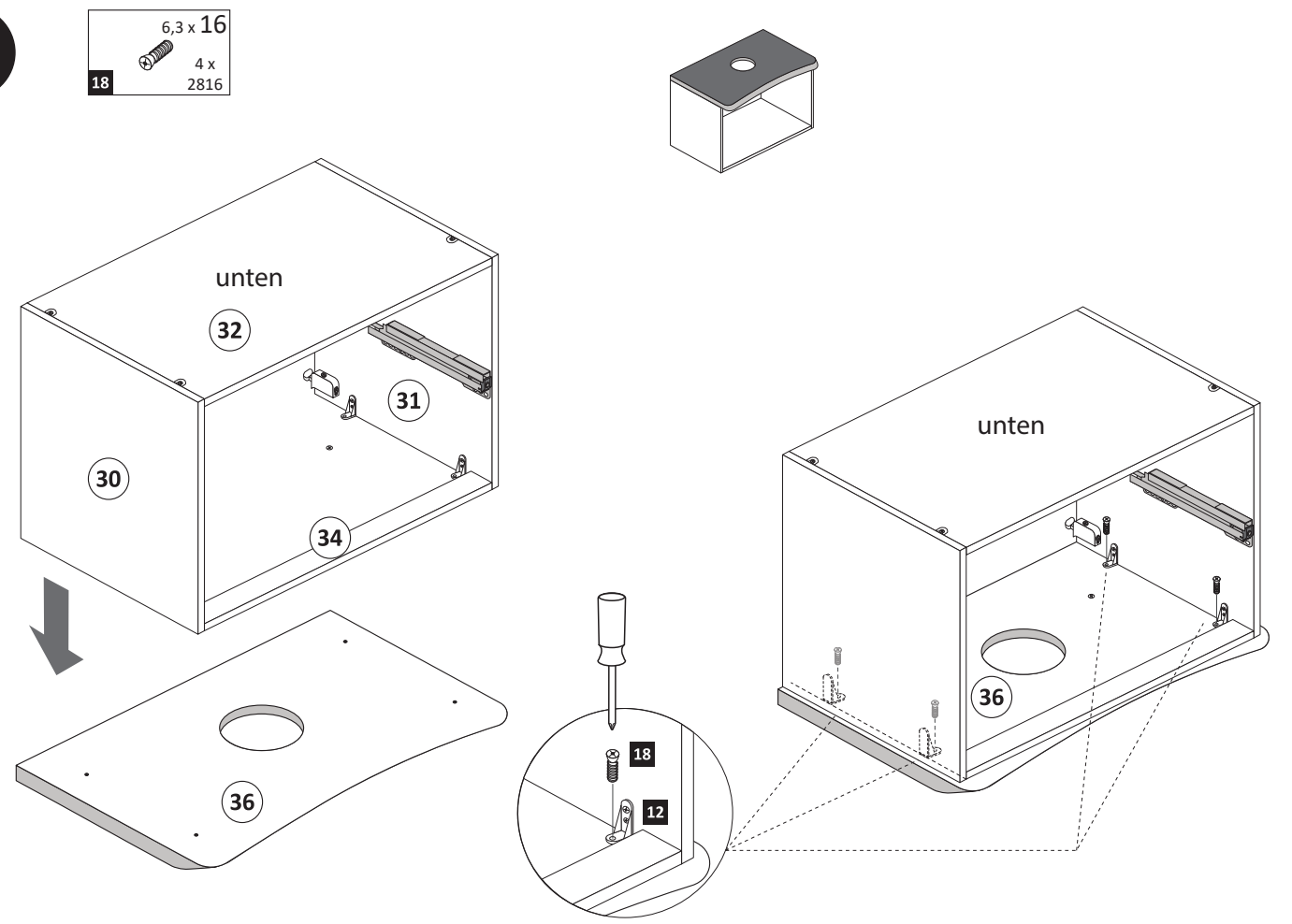

	6,3 x 16	4 x
18		2816

5

	4 x 9	5 x 30
23	4 x	2 x

Variante
Waschtisch 120 cm

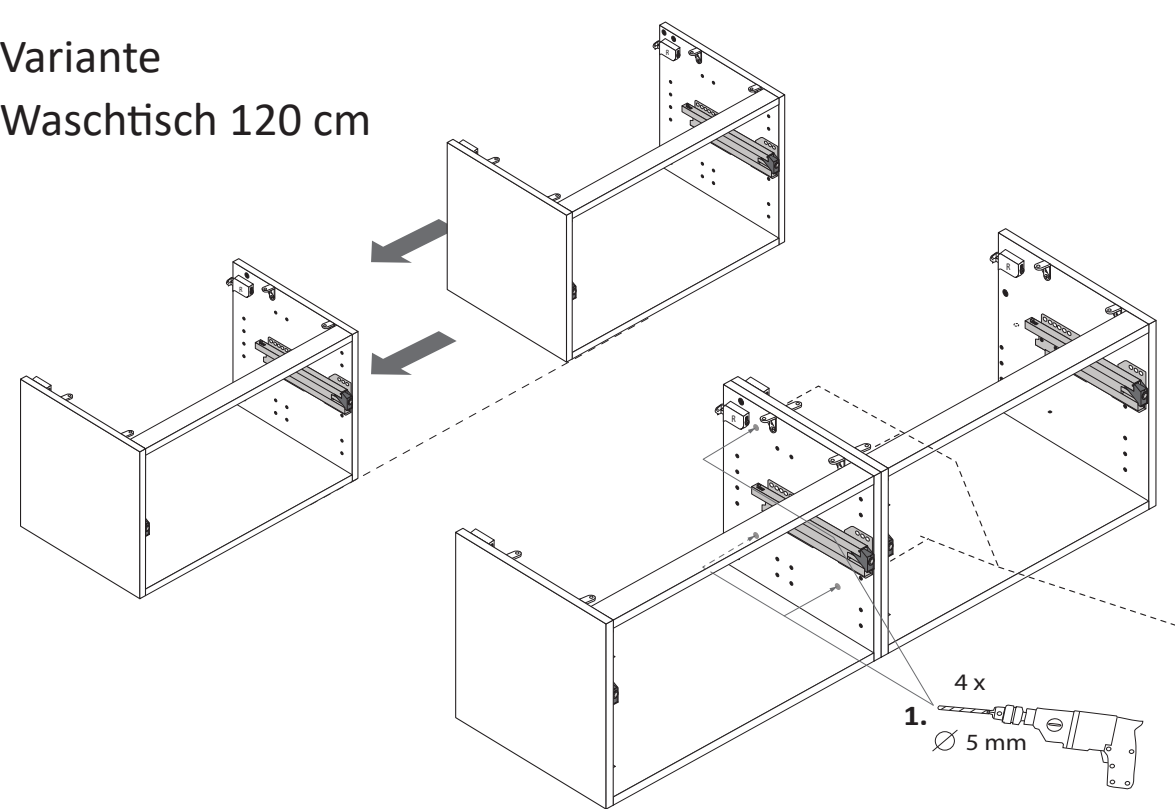

	6,3 x 16	8 x
18		2816

Befolgen Sie bitte
den Montageschritt **4**,
für die Montage der
120'er Platte.

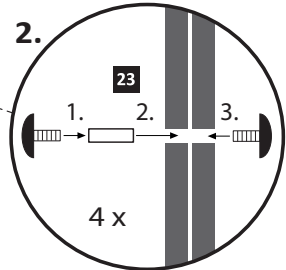

6

	9	2 x
		2865
	6,3 x 16	4 x
18		2816
	19	2 x
		1121

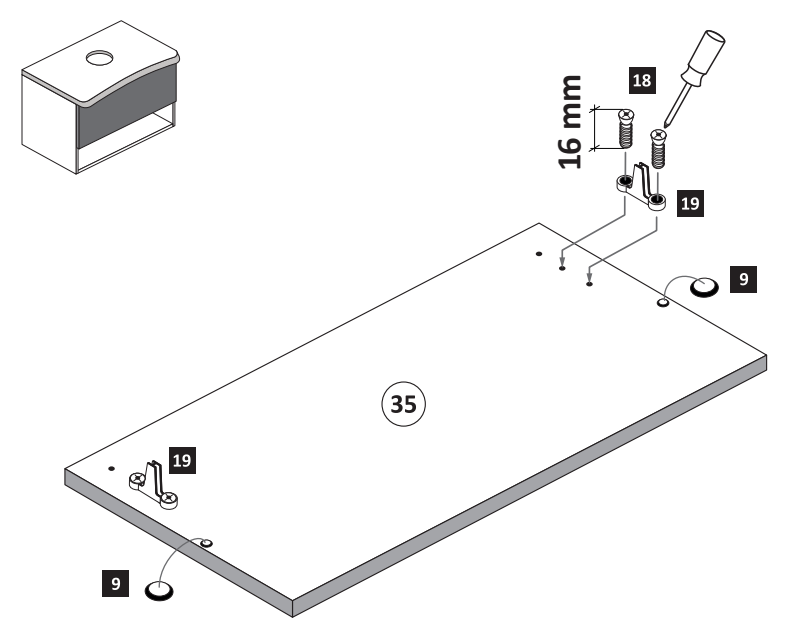

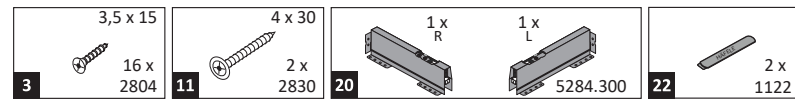
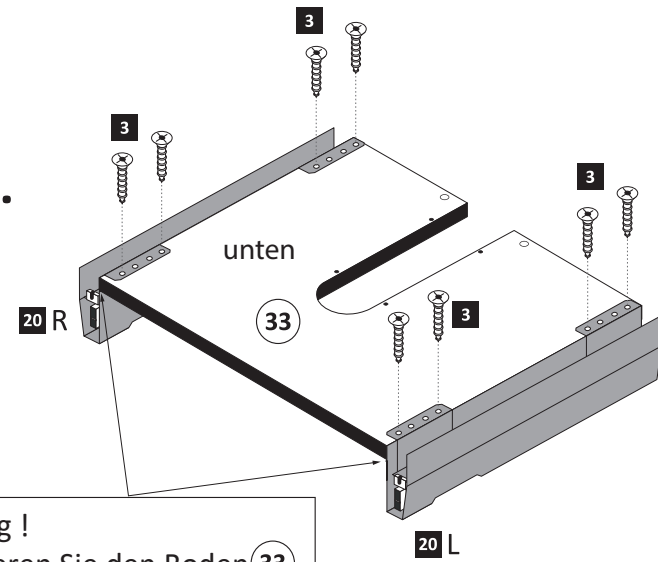
7**1.**

Wichtig !
Montieren Sie den Boden (33)
an der Vorderkante bündig
mit der Zarge (20) !

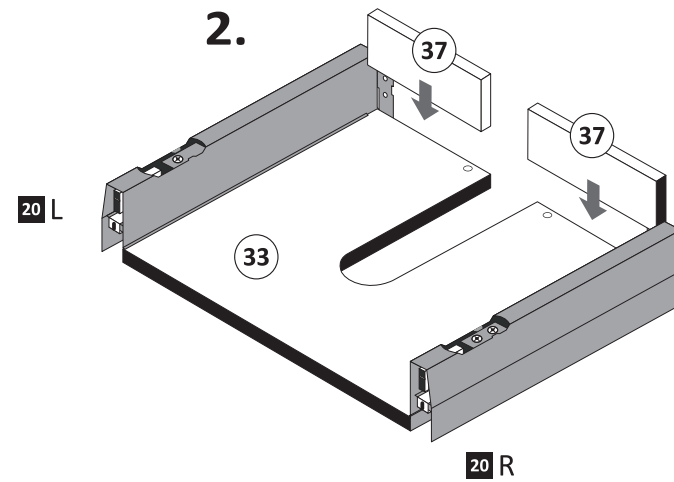
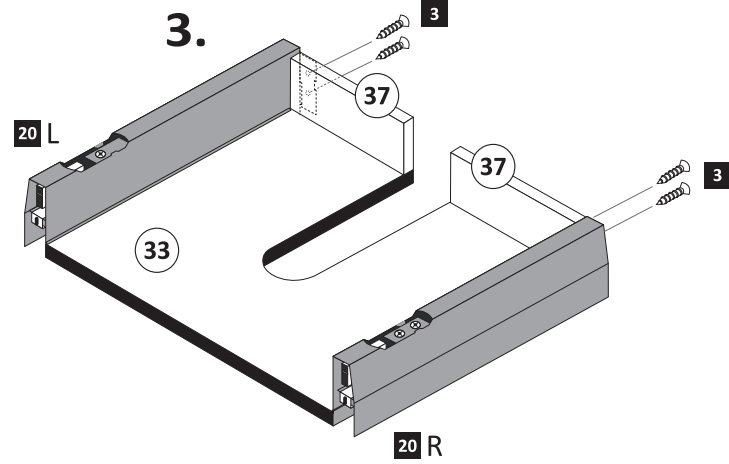
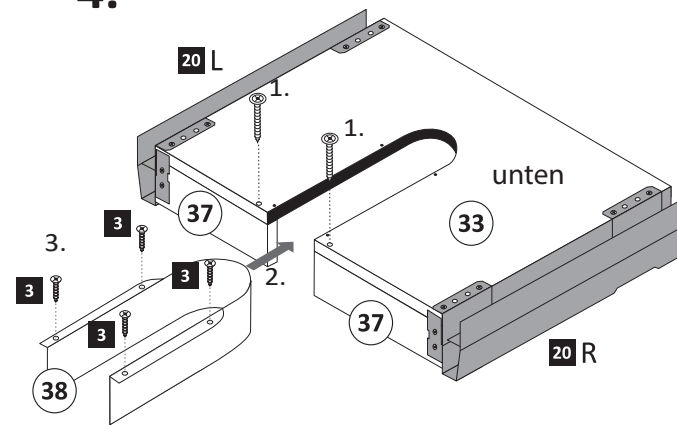
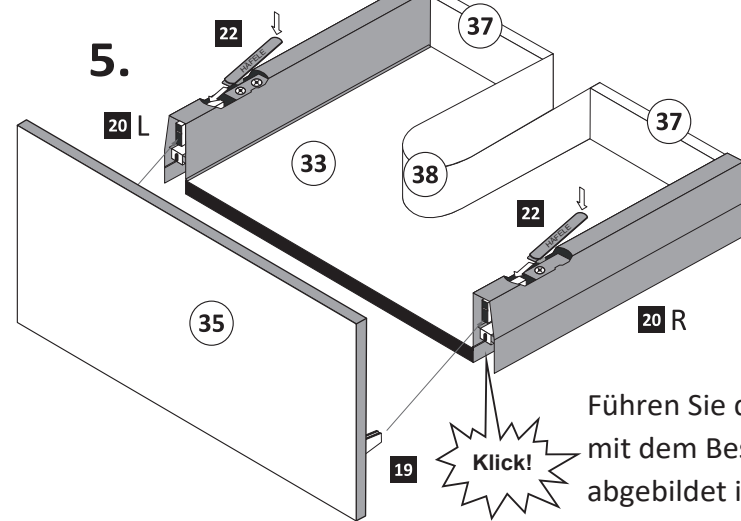
2.**3.****4.****5.**

Führen Sie die Schubkastenblende
mit dem Beschlag (19) wie
abgebildet in die Zargen (20)
ein. Der Beschlag (19) rastet ein !

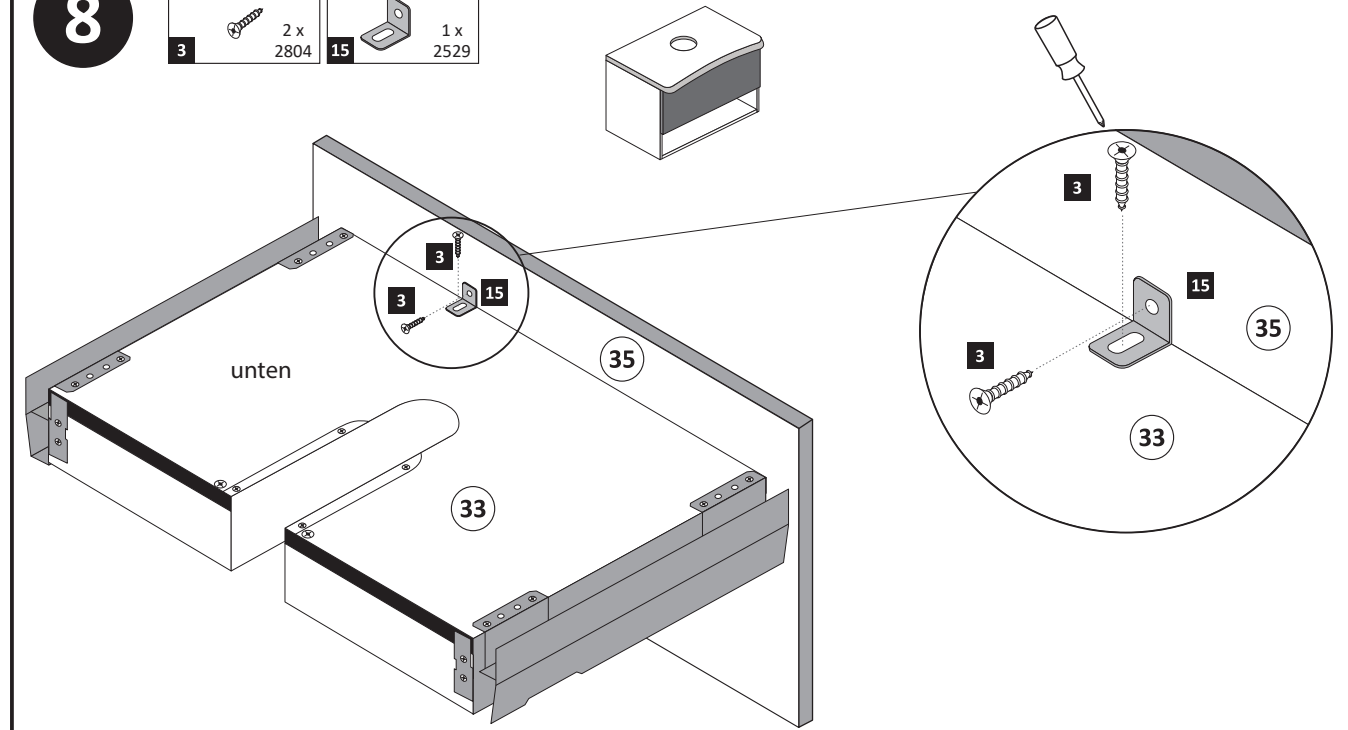
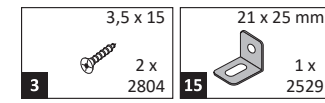
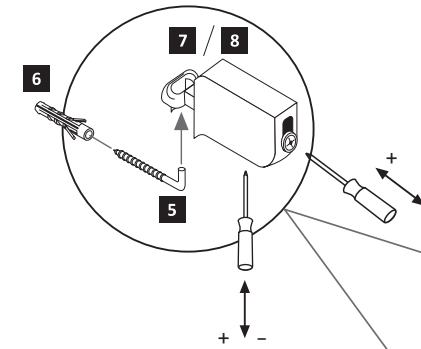
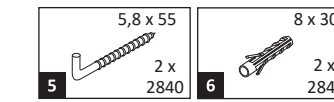
Klick!**8****9****Achtung !**

Bitte hängen Sie die Schubkästen
erst nachdem Sie die Wandmontage
durchgeführt haben ein.

Hinweis !

Wie Sie den Schubkasten einhängen müssen,
entnehmen Sie bitte dem beigefügten
Montagezettel.

Zusätzlich finden Sie auf dem Montagezettel
folgende Abbildungen und Montagehilfen:

- Einstellen der Schubkastenblende
- Aushängen des Schubkastens
- Abnehmen der Schubkastenblende

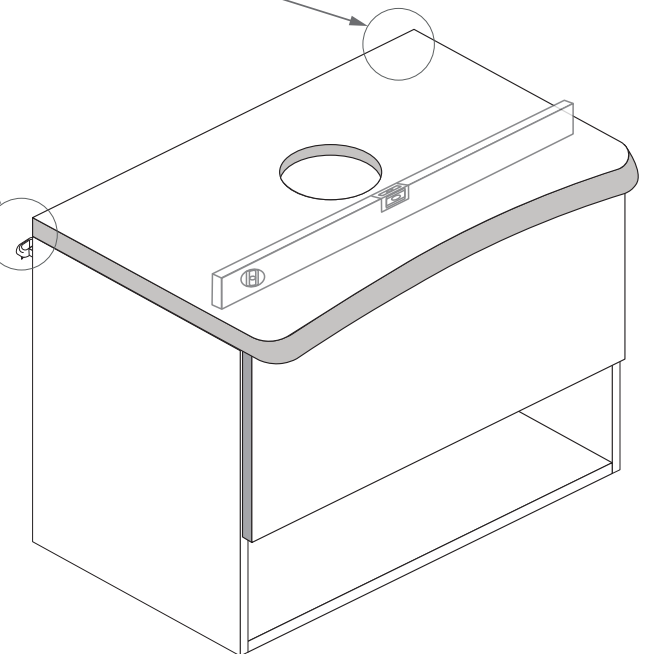

Montage Aufsatz-Waschbecken

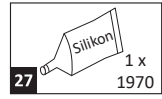
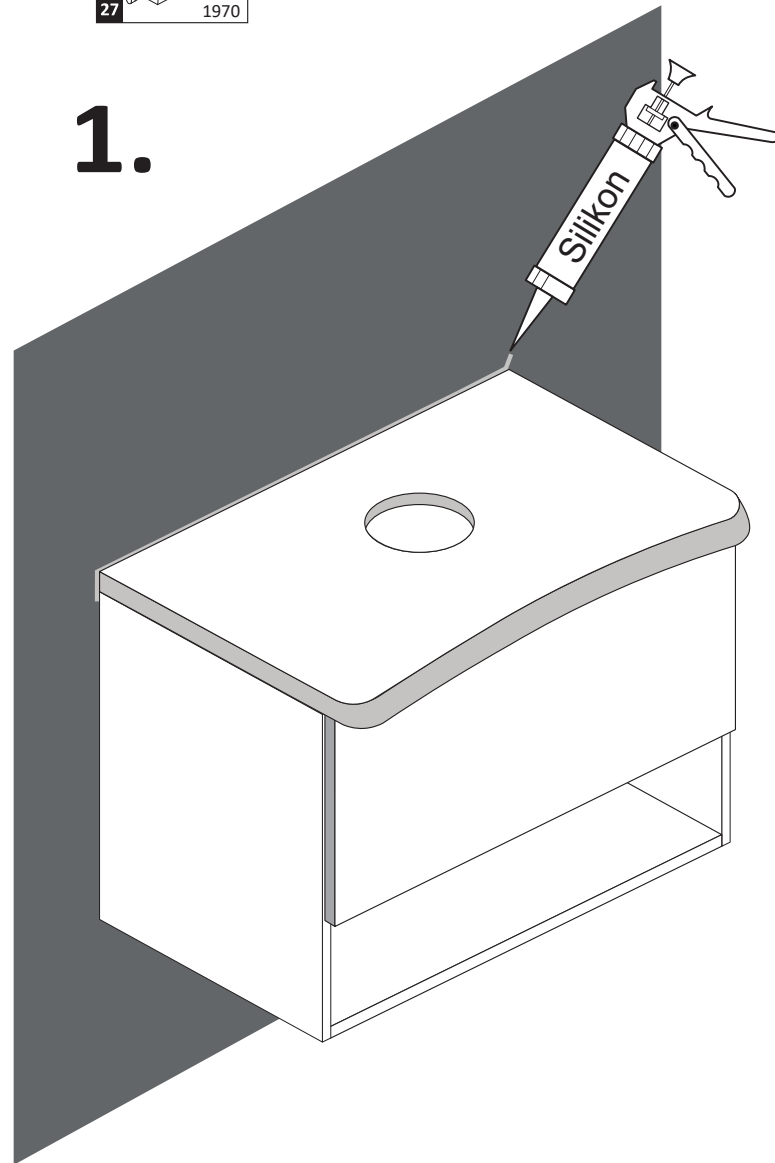
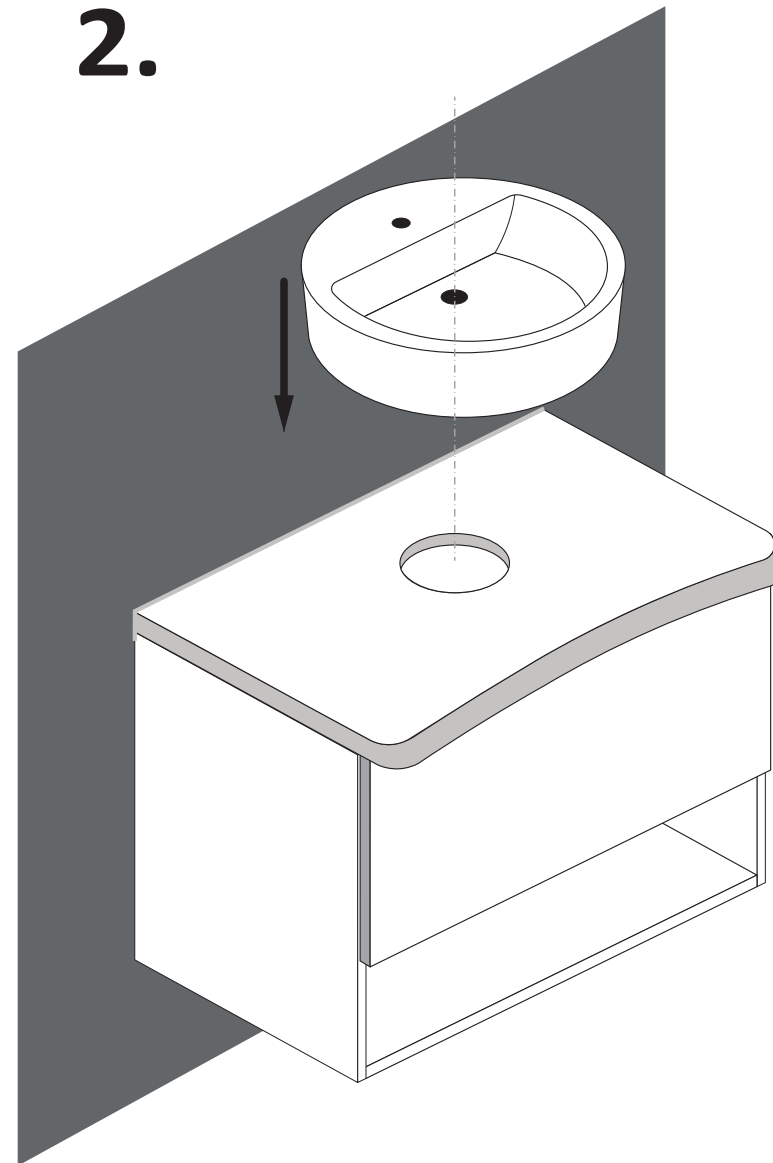
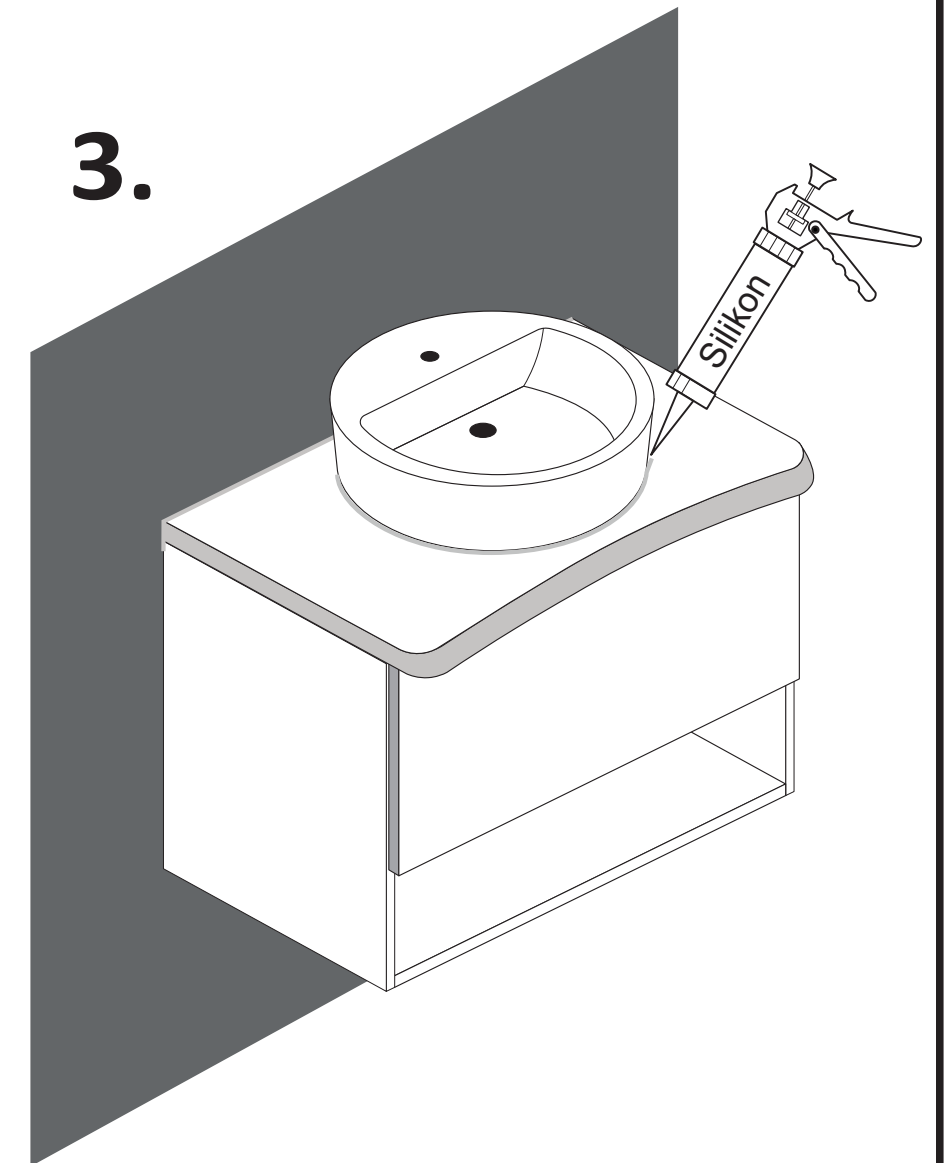
**1.****2.****3.**

**Mitgelieferte Silikon reicht
nicht für die gesamte
Beckenmontage aus!**



89944.330

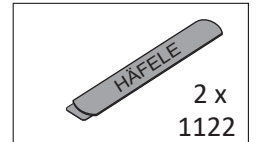
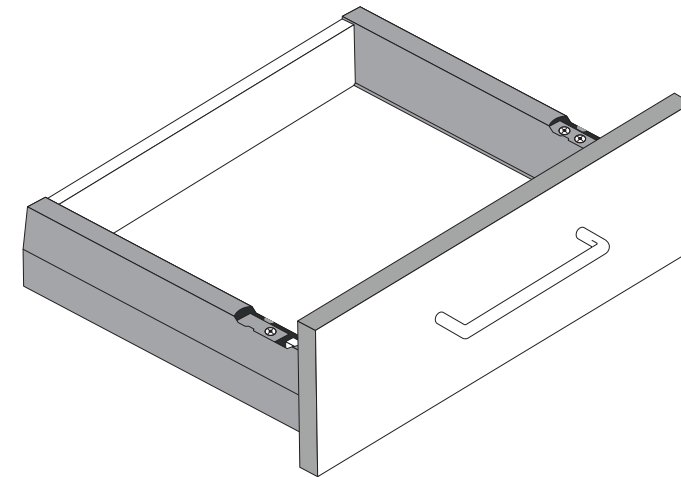
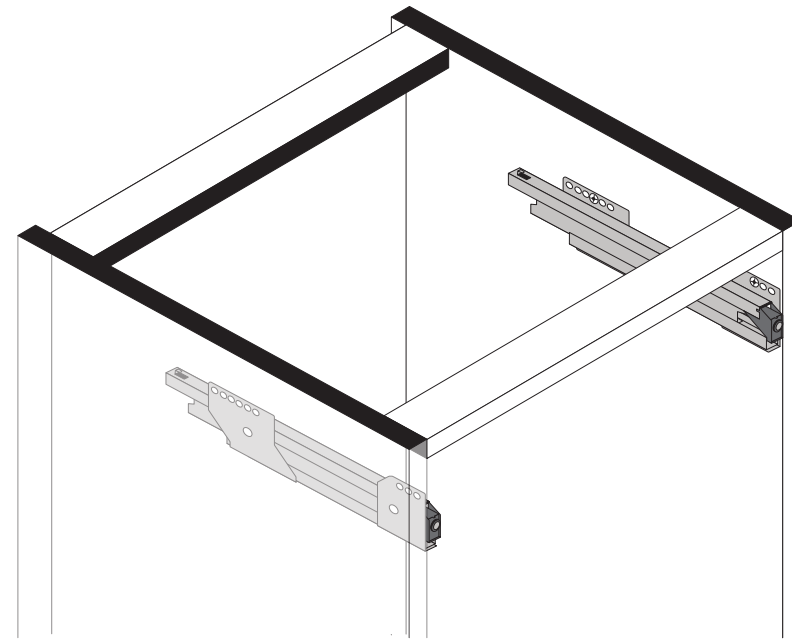
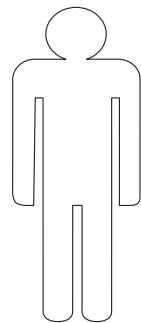
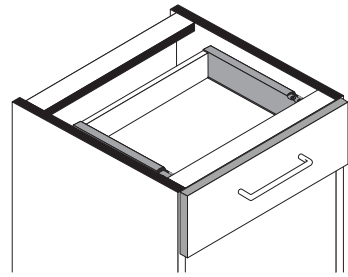

1

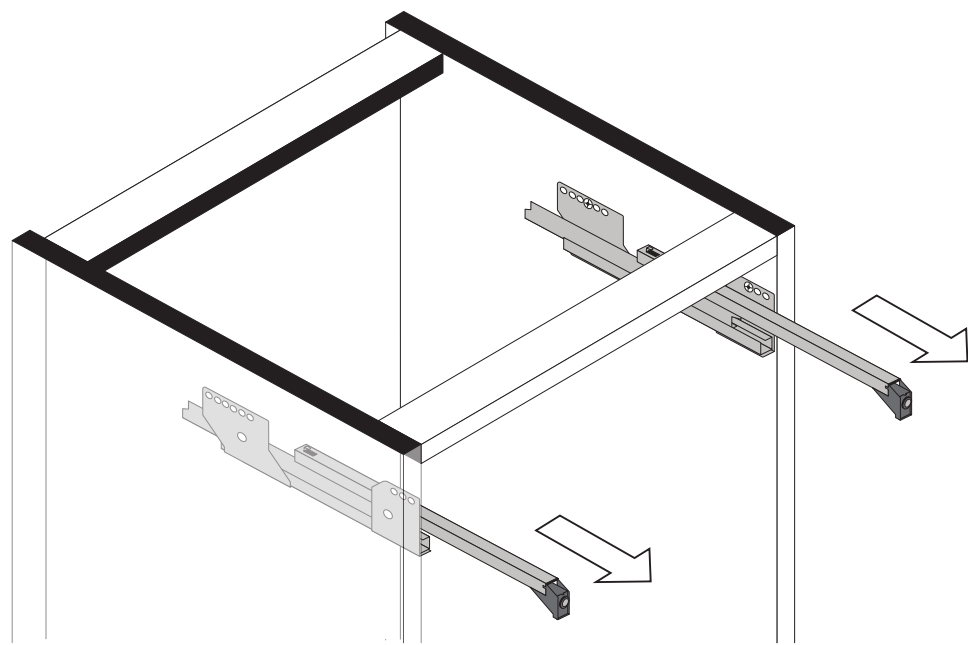

2

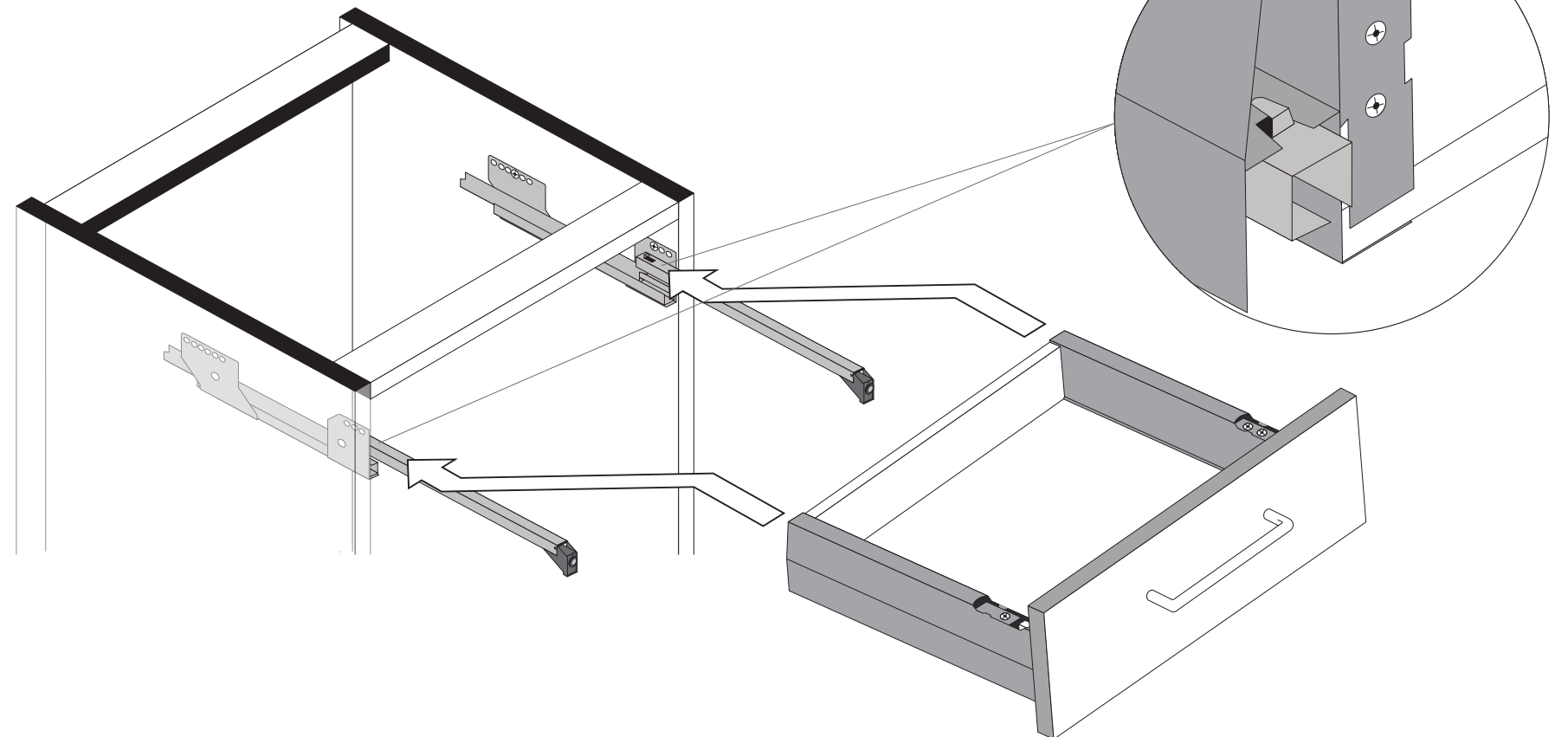

3

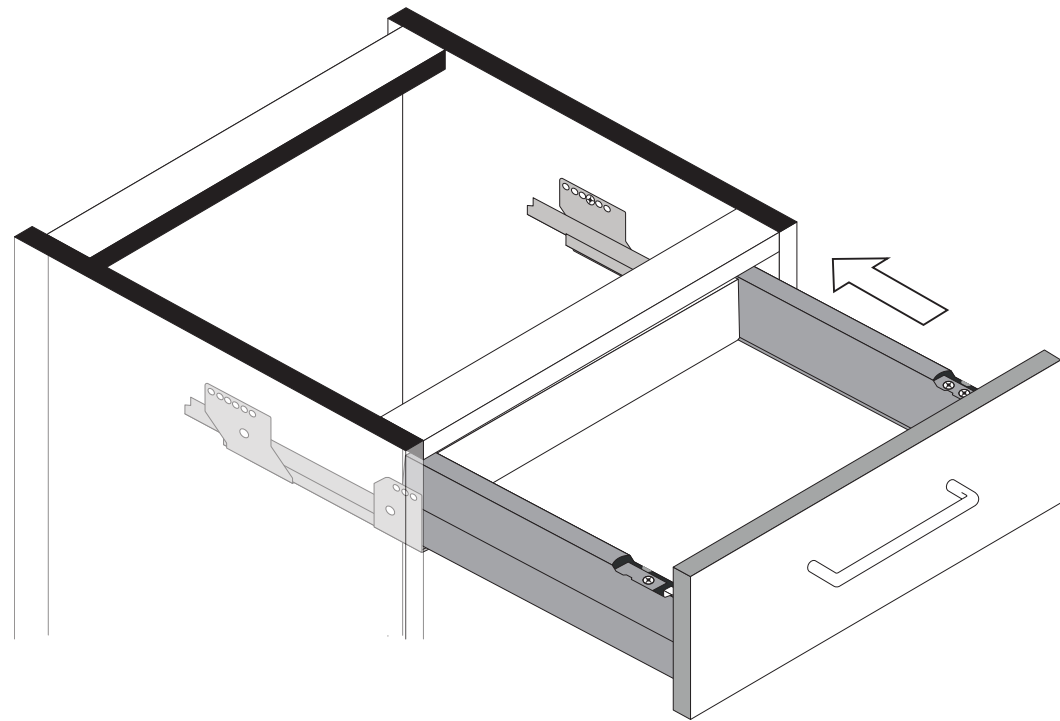

4

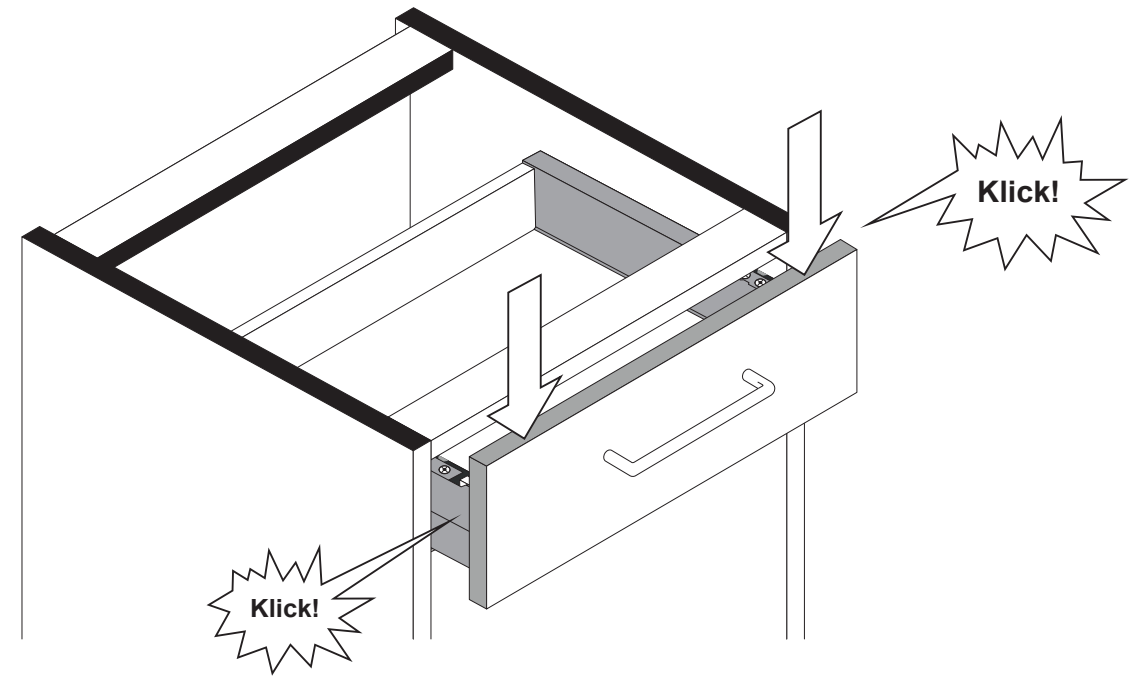

5

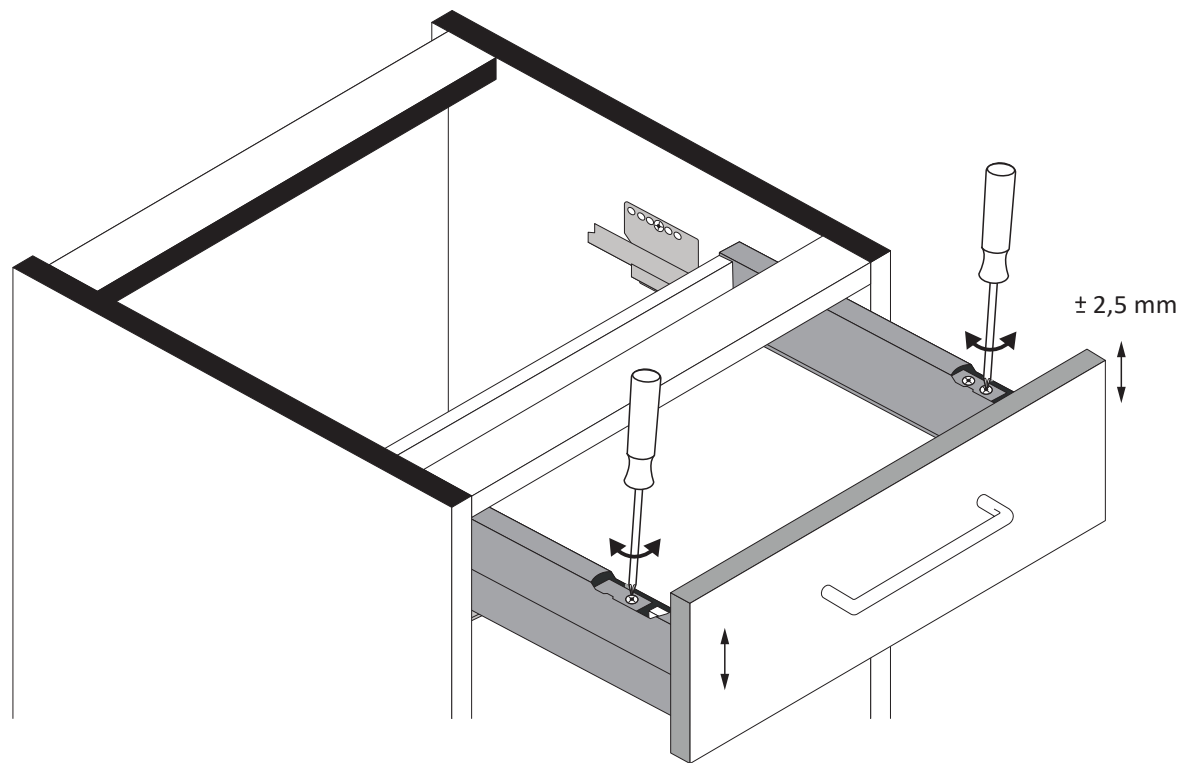

6

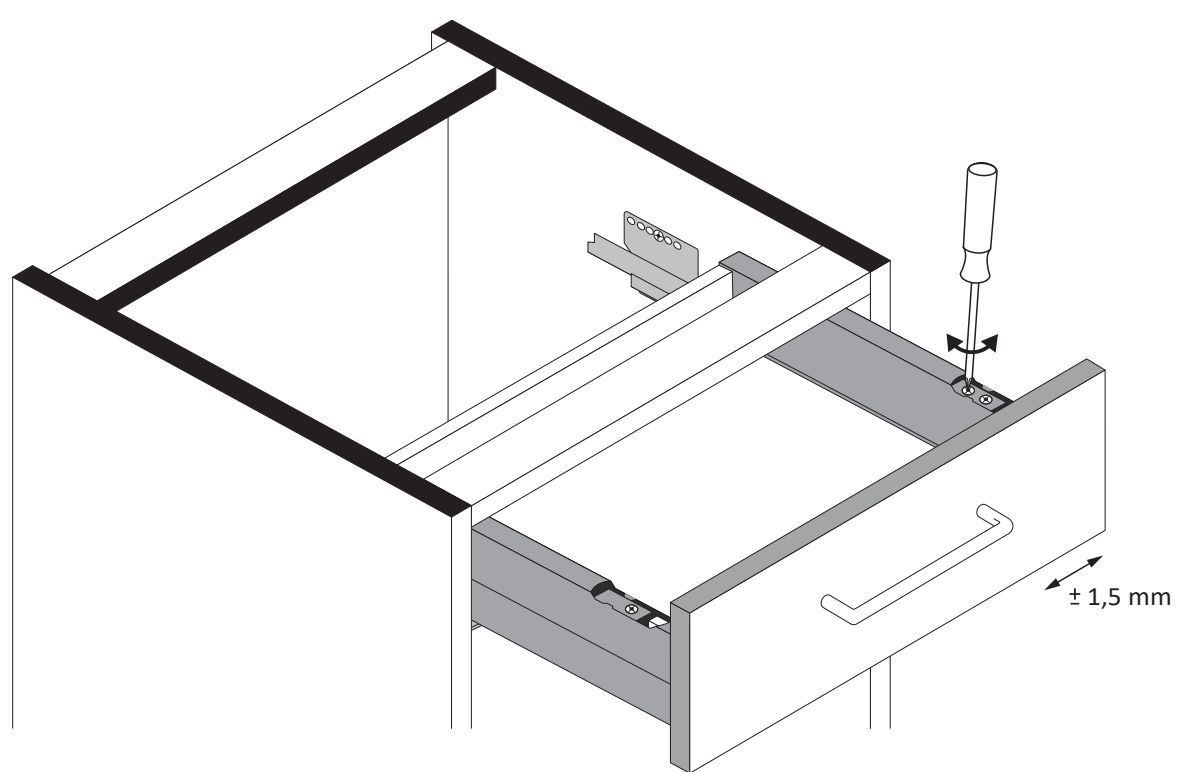

7

