

1 → 2 → 3 ...

- 1**
- 8x Nr.98
- 4x Nr.502
- 2x Nr.89
- 4x 6,3x12,5 Nr.451
- 2x 3,5x13 Nr.153
- 2**
- 8x Nr.76
- 14x Ø8x30 Nr.80

Montageanleitung

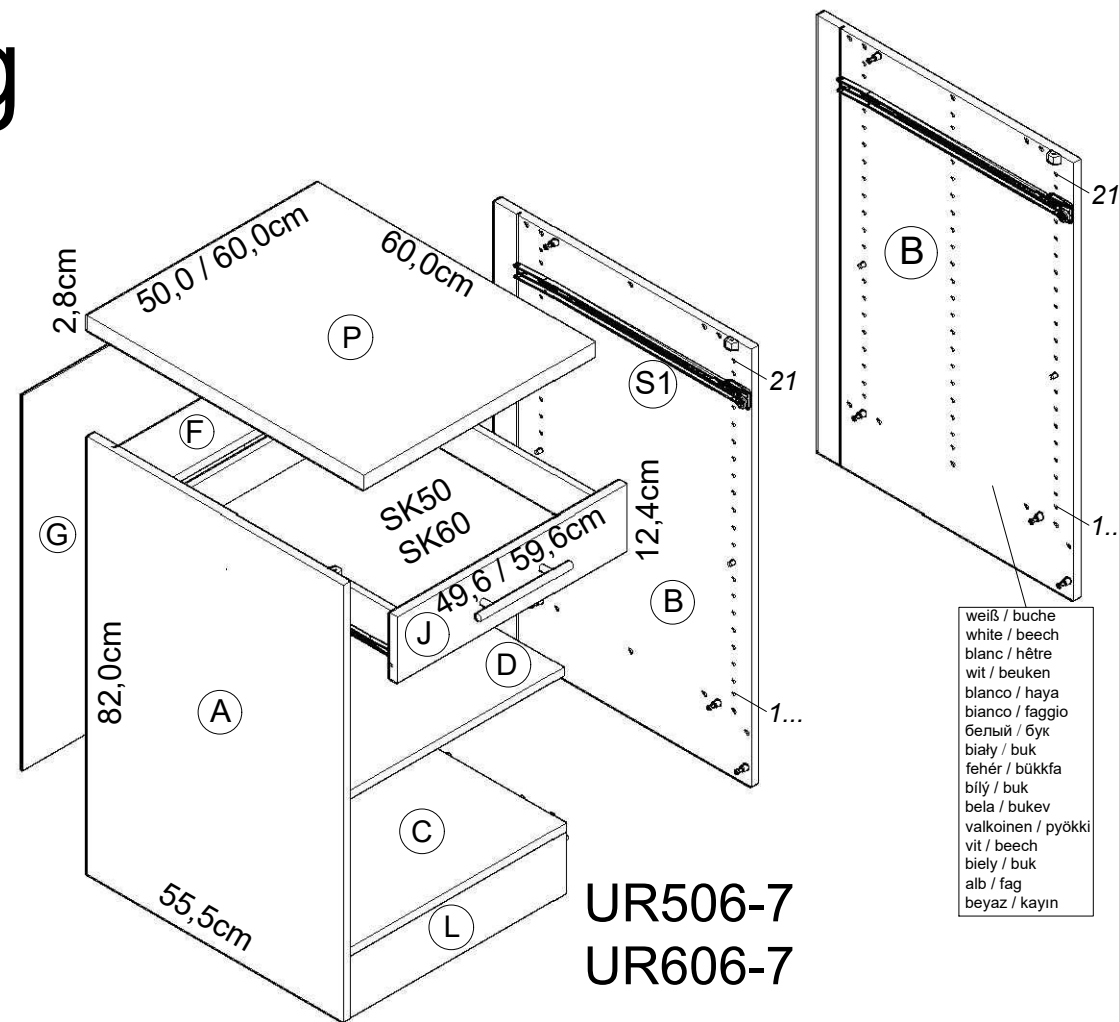
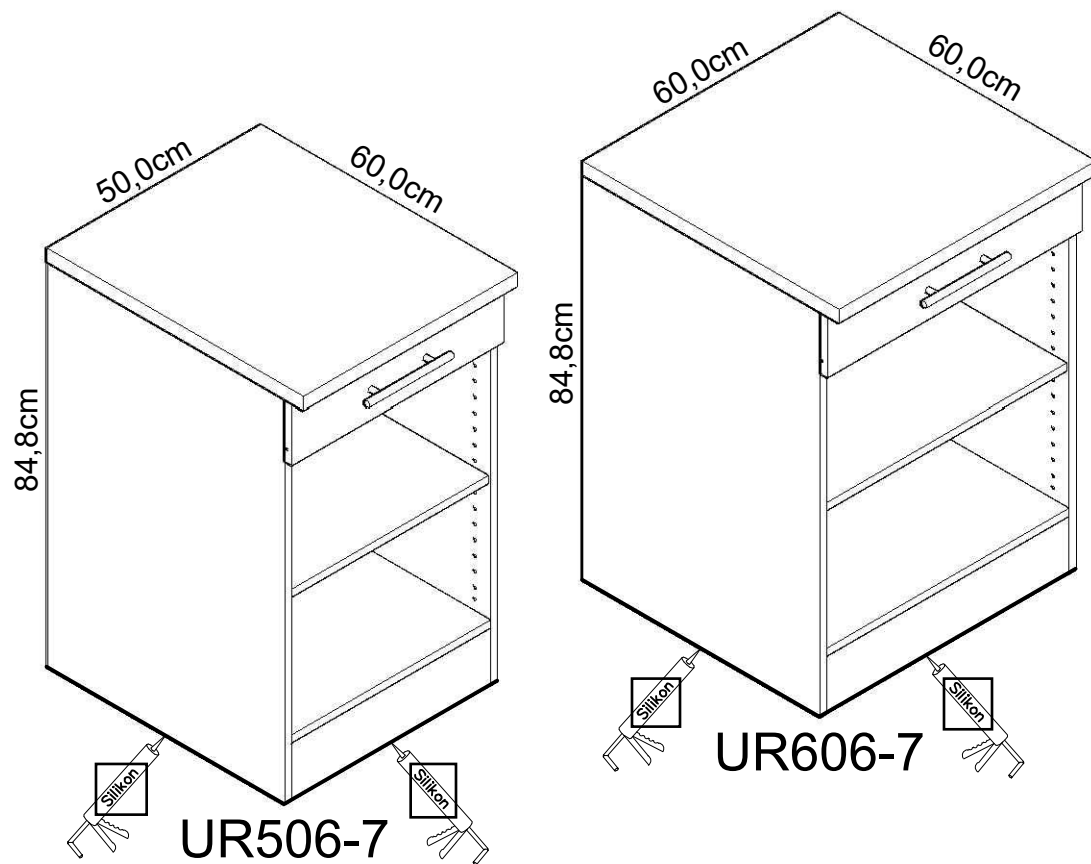

weiß / buche
white / beech
blanc / hêtre
wit / beuken
blanco / haya
bianco / faggio
белый / бук
biały / buk
fehér / bükkfa
bílý / buk
bela / bukev
valkoinen / pyökki
vit / beech
biely / buk
alb / fag
beyaz / kayın

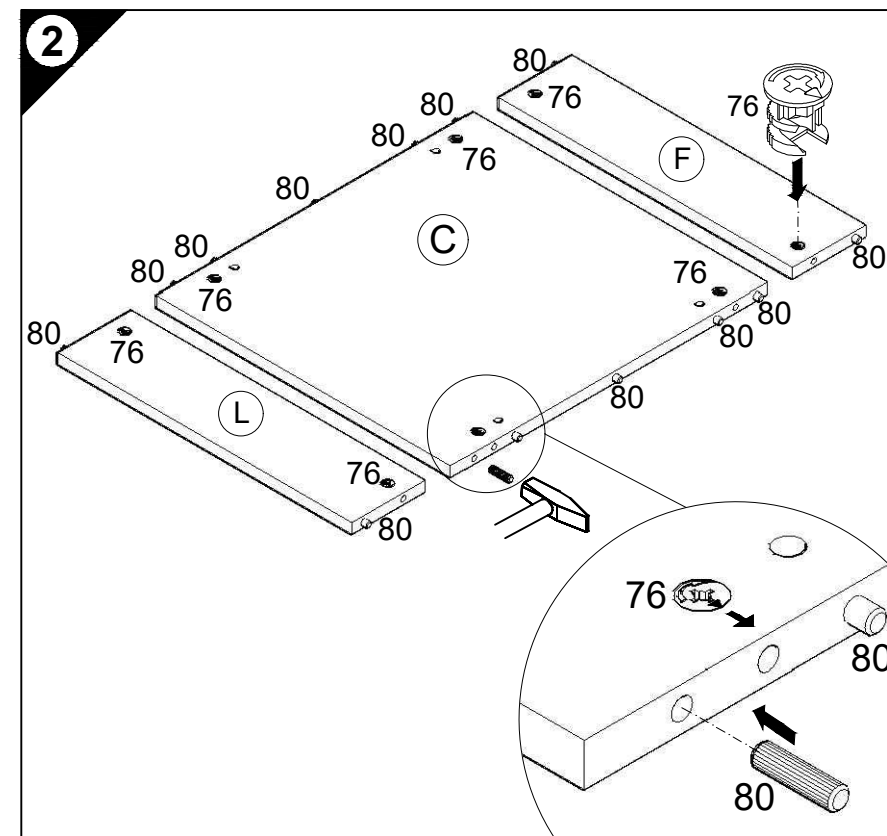
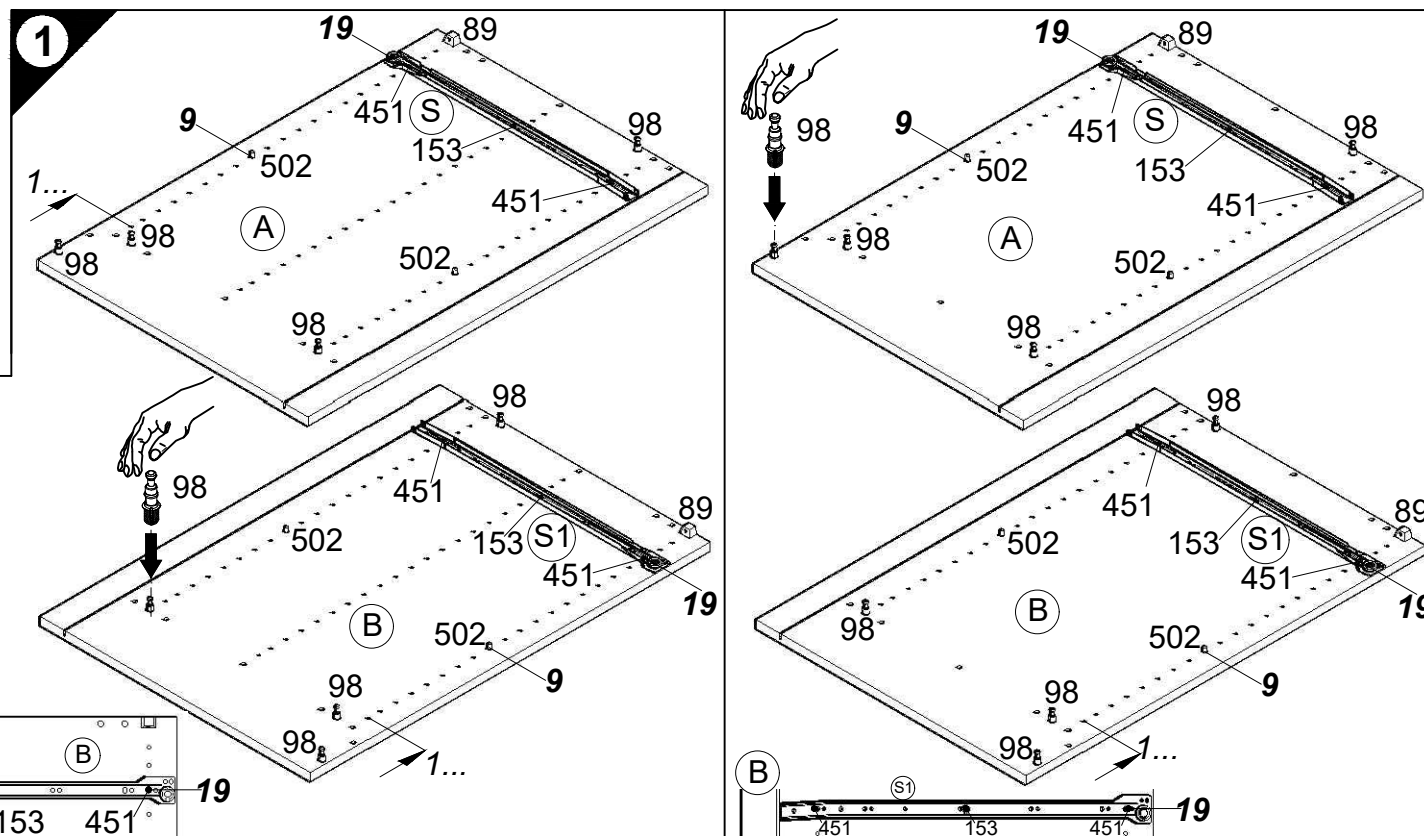

weiß / buche
white / beech
blanc / hêtre
wit / beuken
blanco / haya
bianco / faggio
белый / бук
biały / buk
fehér / bükkfa
bílý / buk
bela / bukev
valkoinen / pyökki
vit / beech
biely / buk
alb / fag
beyaz / kayın

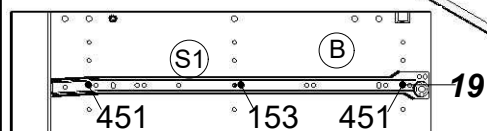

Service-Hotline
01805-678101
0,14€ pro Minute
++49 für Österreich
Auslandstarif pro Minute
service@jaka-bkl.de
voor Nederland en België
00800-40119350
benelux@jaka-bkl.de

Ersatzteile/Spare parts/pièces de rechange/Reserveonderdelen/Piezas de recambio/Ricambi/Запасные части/Części zamienne/pótalkatrészek/Náhradní části/Nadomestni deli/varaosat/reservdelar/náhradné diely/Utilizați piese de schimb/Yedek parçalar

50cm UR506-7	[A] E961021	[B] E961022	[C] E954224	[D] E950304	[F] E970974	[G] E970117	[J] E947563	[L] E970974	[P] E540104	[S] E946155	[S1] E946155
weiß/buche UR506-7	[A] E981021	[B] E981022	[C] E954224	[D] E950304	[F] E970974	[G] E970117	[J] E947563	[L] E970974	[P] E540104	[S] E946155	[S1] E946155
60cm UR606-7	[A] E961021	[B] E961022	[C] E954223	[D] E950303	[F] E970973	[G] E970116	[J] E947562	[L] E970973	[P] E540103	[S] E946155	[S1] E946155
weiß/buche UR606-7	[A] E981021	[B] E981022	[C] E954223	[D] E950303	[F] E970973	[G] E970116	[J] E947562	[L] E970973	[P] E540103	[S] E946155	[S1] E946155

1 → 2 → 3 ...

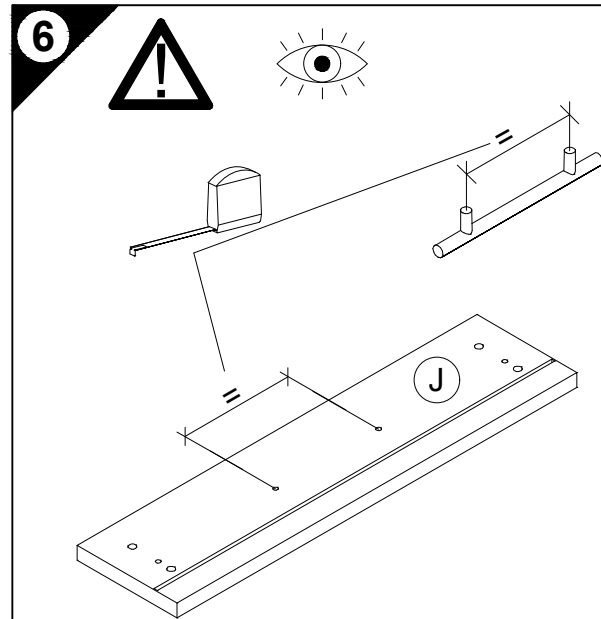
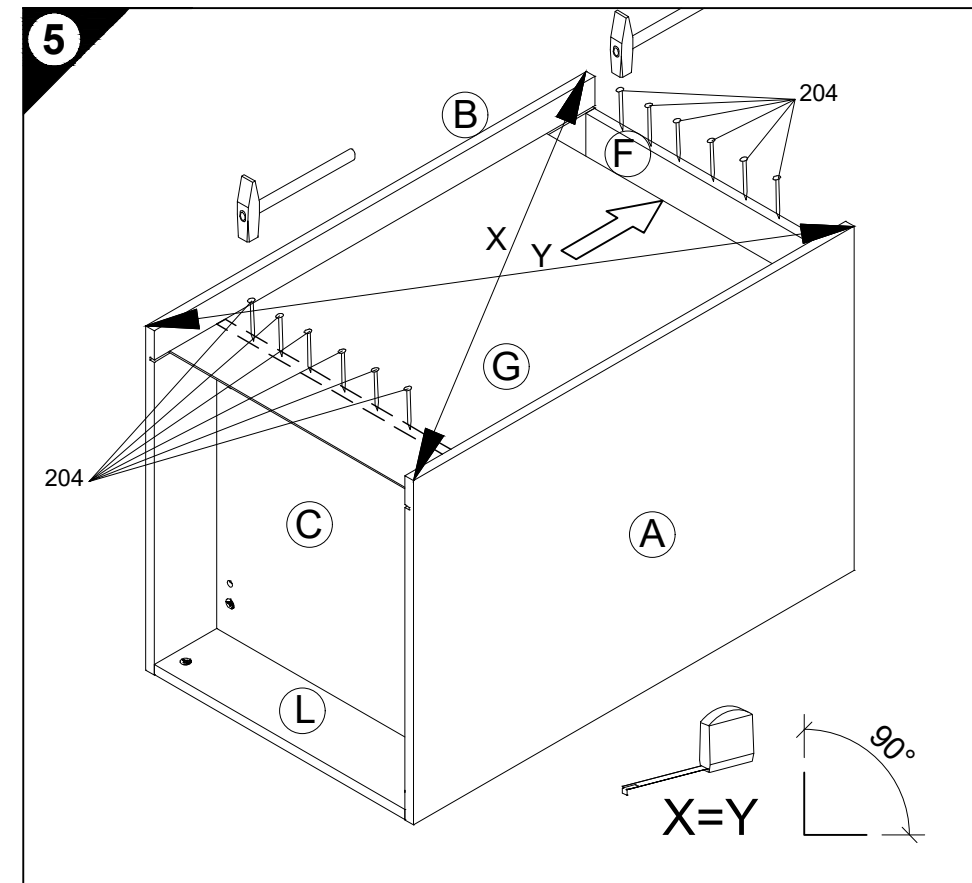
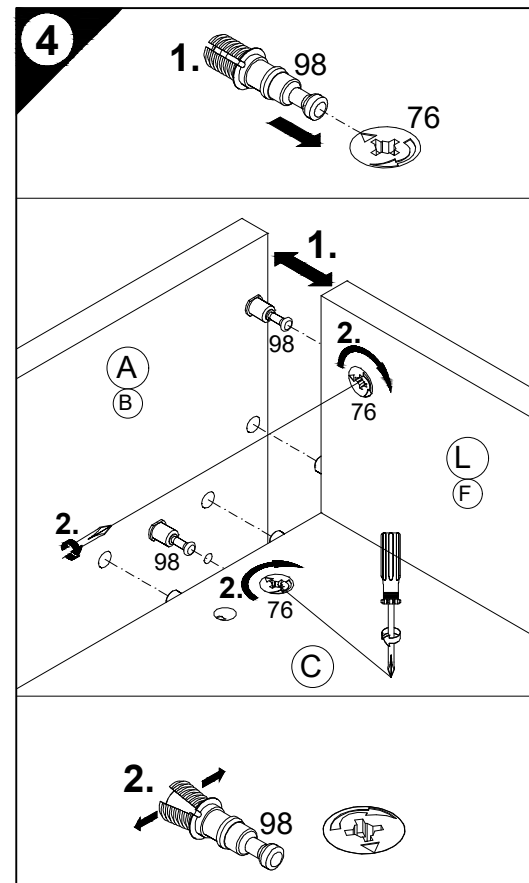
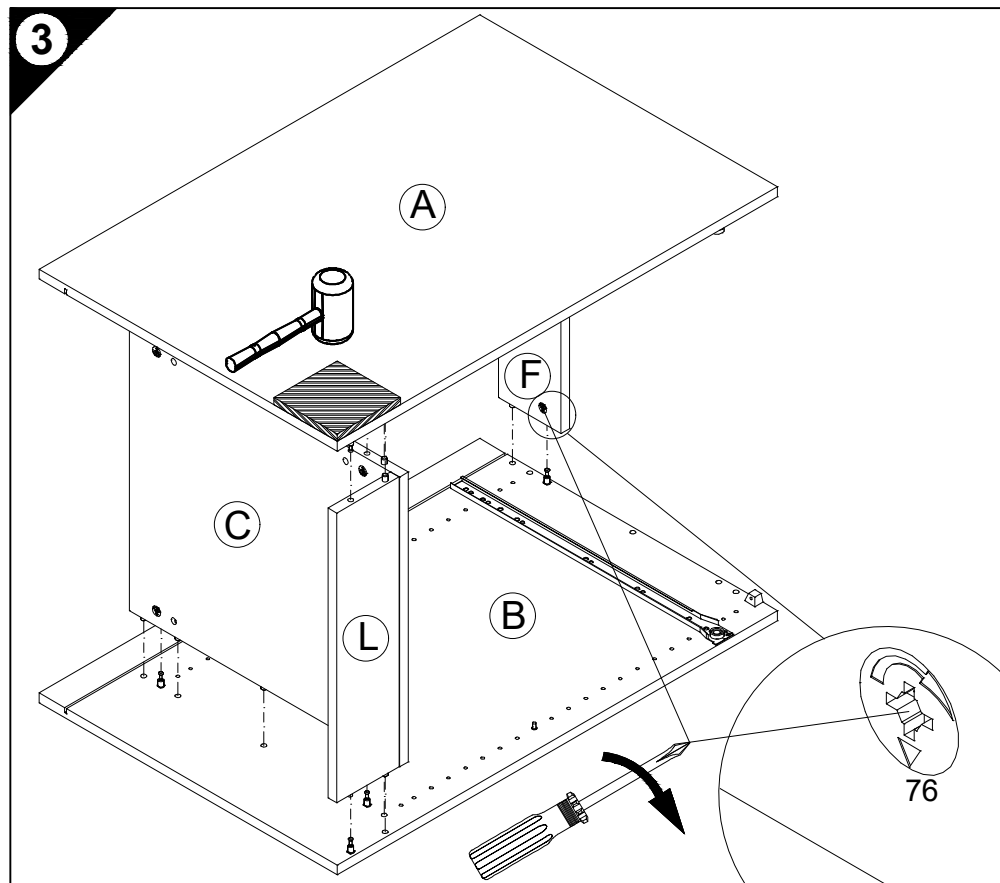
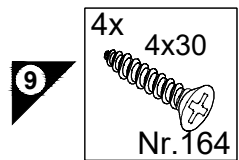
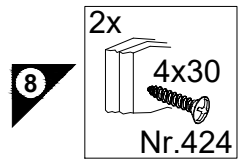
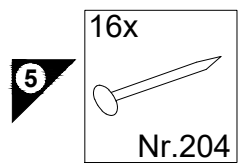

D Holzunterlage verwenden!
Front andrücken, scharfen Bohrer verwenden
und mit wenig Druck durchbohren!

GB Use a wooden base!
Press front down, use sharp drill bit
and, by applying slight pressure, drill a hole

F Utiliser un support en bois !
Appuyer sur la façade, utiliser un foret bien affûté
et percer en appliquant une faible pression !

NL Houten onderlegger gebruiken!
Druk het front aan, gebruik een scherpe boor
en oefen bij het boren weinig druk uit!

E ¡Utilizar una base de madera!
¡Presionar el frente, utilizar una broca afilada
y taladrar con poca presión!

I Utilizzare una base di legno!
Appoggiare la facciata, utilizzare una punta di trapano affilata
e trapanare esercitando solo una leggera pressione!

RUS Использовать деревянную подложку!
Прижать фасад, использовать острое сверло
и просверлить с незначительным давлением!

PL Używać podkładkę z drewna!
Docisnąć front, użyć ostrego wiertła
i przewiercić, używając małej siły nacisku!

H Alkalmazzon fa alátétet!
Nyomja le az előlapot, használjon éles fúrót,
és kis nyomással fúrja át!

CZ Použijte dřevěný podklad!
Přitlačte čelo, použijte ostrý vrták
a provrtějte pomocí malého tlaku!

SLO Uporabite leseno podlago!
Pritisnite ličnico ter z ostrim svedrom
in z majhnim pritiskom izvrtajte luknjo!

FIN Käytä puualustaa!
Paina etulevy paikoilleen, käytä terävää poranterää
ja poraa reikä vain kevyesti painamalla!

S Använd ett träunderlag!
Tryck fronten mot underlaget, använd vass borr
och borra igenom med ett lätt tryck!

SK Použite drevený podklad!
Pritlačte front, použite ostrý vrták a prevrtajte miernym tlakom!

RO suport de lemn! Împingeți frontul, utilizați un burghiu ascuțit
și perforați exercitând doar o presiune redusă!

TR Ahşap taban kullanın!
Önden bastırın, keskin matkap ucu kullanın ve az basınç
uygulayarak delin!

