

Timbon

50-228-HM

1/8

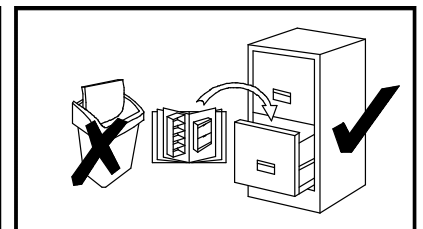
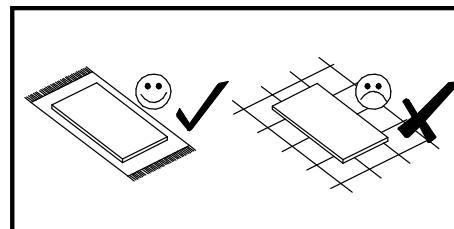
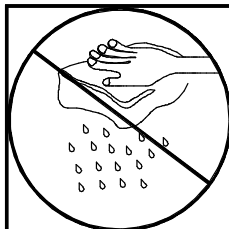
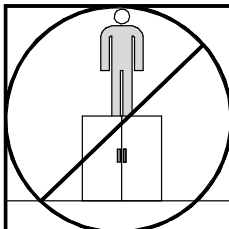
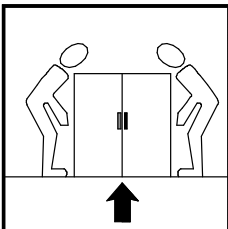
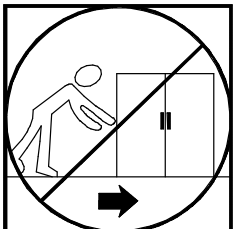
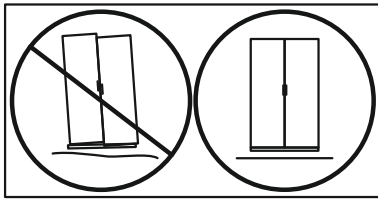
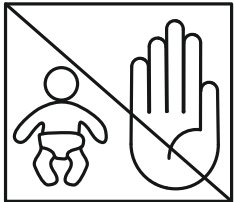
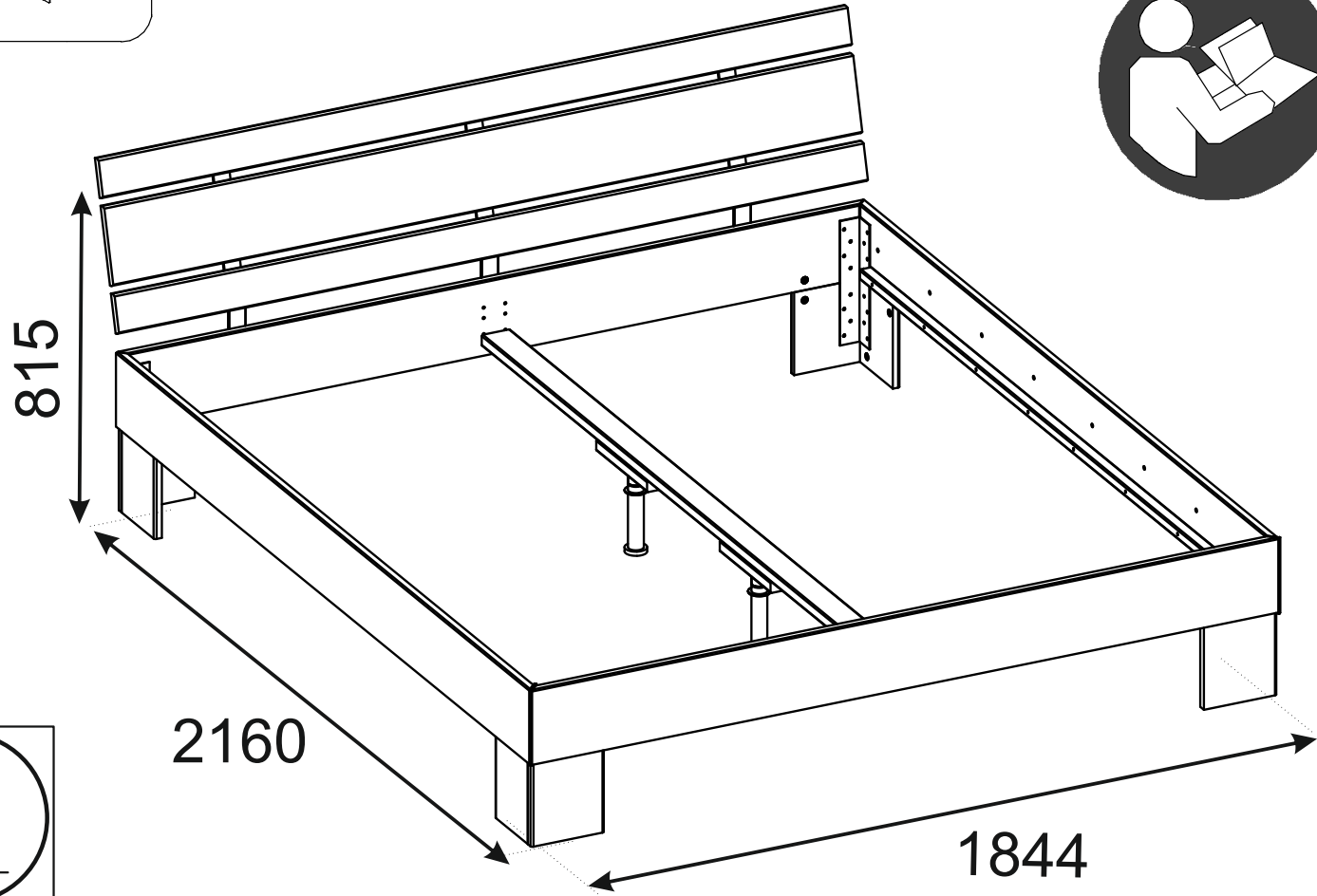
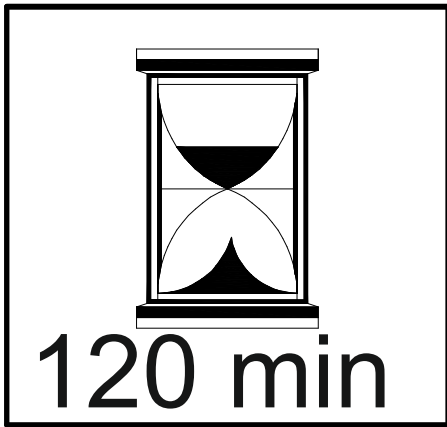
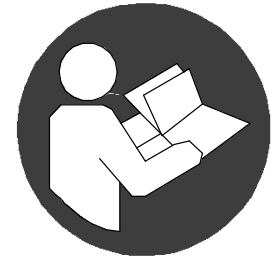
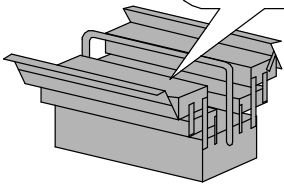
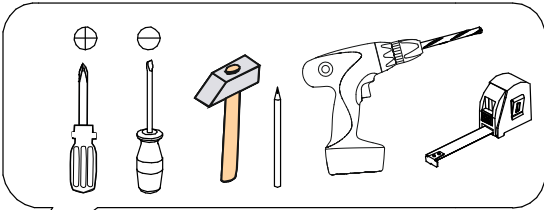
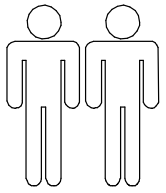

Timbon

50-228-HM

64x Ø6,3x13 mm e2	8x Ø6x13 mm e3	21x Ø6x20 mm e20	24 x Ø8x30 mm f1	16x Ø8x50 mm f6	8x k1	2x k2412	4x 20/11 r42	8x 40 mm r51	20x Ø16 s2
2x k2413	2x k2414	8x 1x12 mm l16	4x 300x50x50/2 mm n201	2x n3411	2x n3412	16x Ø4x45 mm p11	20x Ø15x12 mm #16 r1	3x 599x40x5 mm n202	4x 182 mm l65
								4x Ø4x45 mm p62	6x Ø3,5x25 mm p16

NR	↙	↗	↖	ST.	📦
1	1880	30	25	2	2
2	1986	70	27	1	2
3	250	70	27	2	2
4	200	180	18	2	2
5	200	162	18	2	1
6	200	180	18	2	1
7	200	162	18	2	2
8	2040	180	22	2	2
9	1440	180	22	1	1
10	1444	90	18	2	1
11	1444	180	18	1	1
12	1440	180	22	1	1

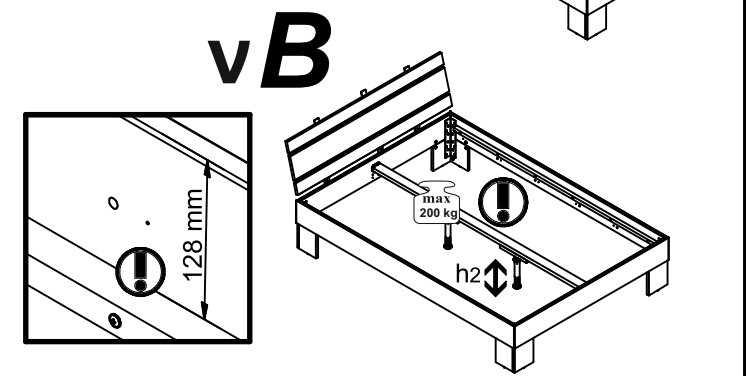
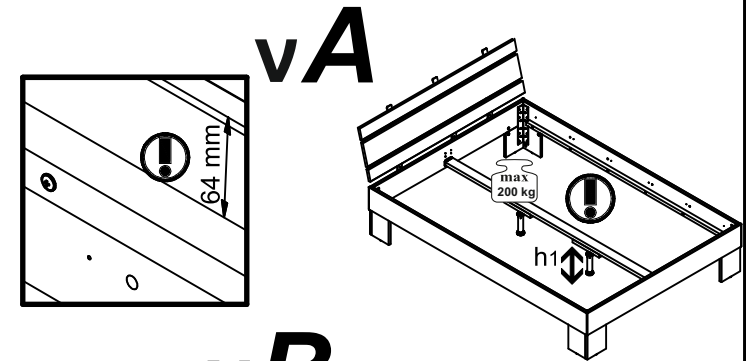
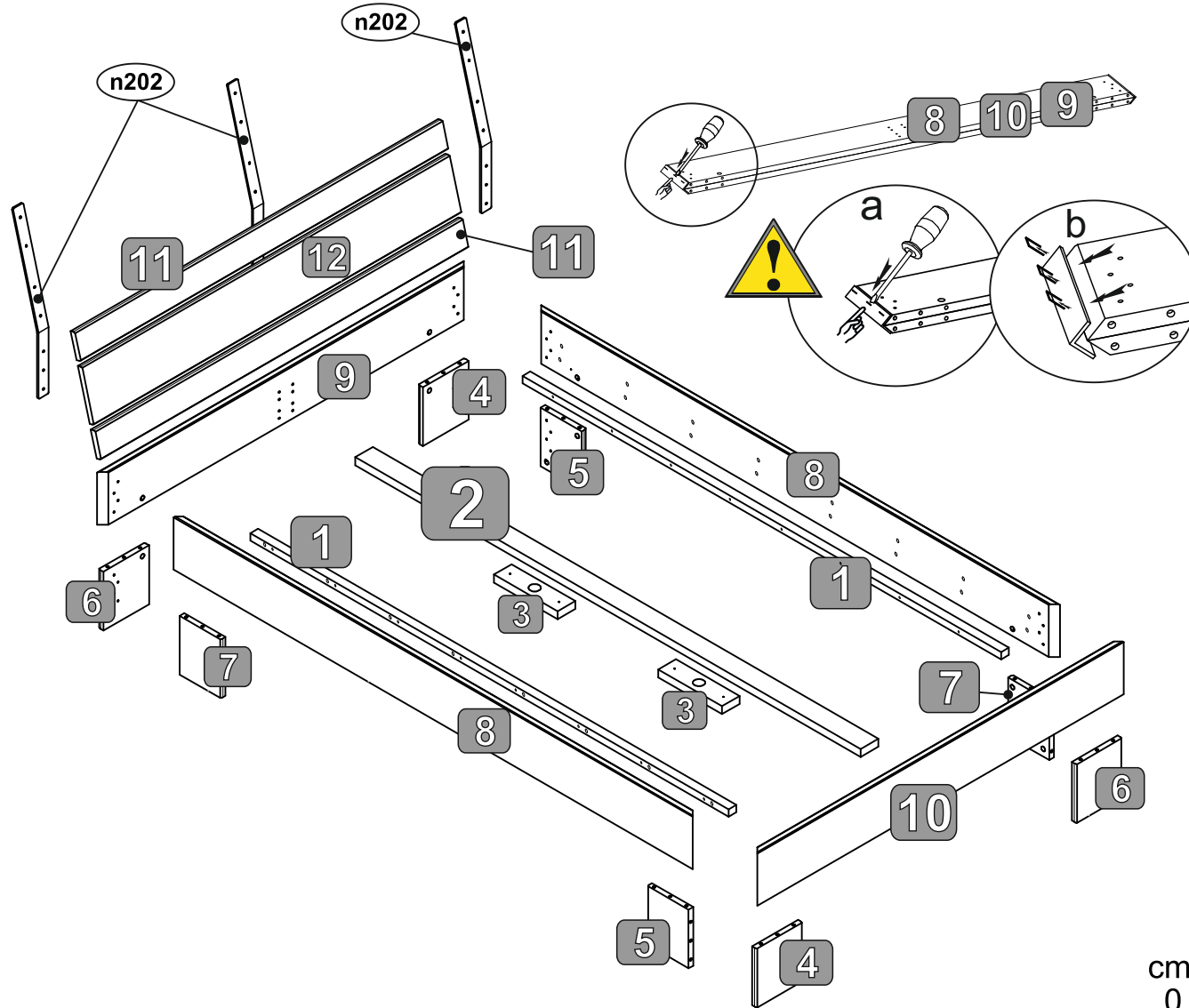

Timbon

50-228-HM



3/8

1

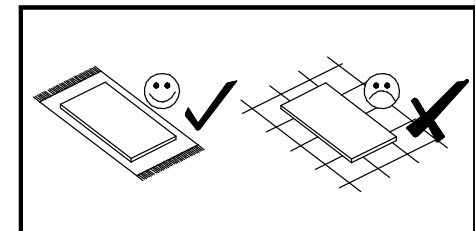
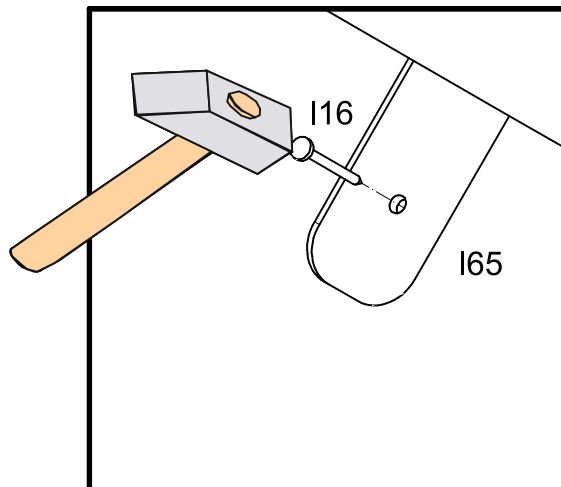
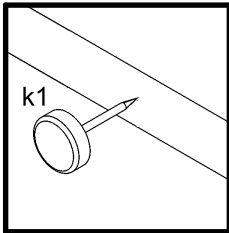
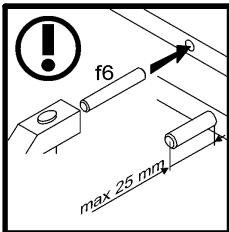
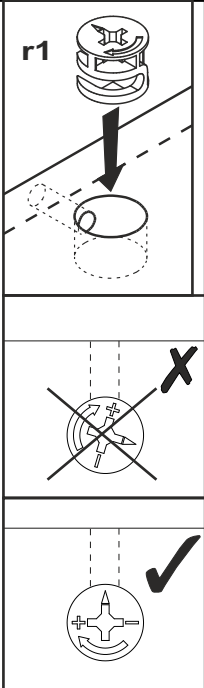
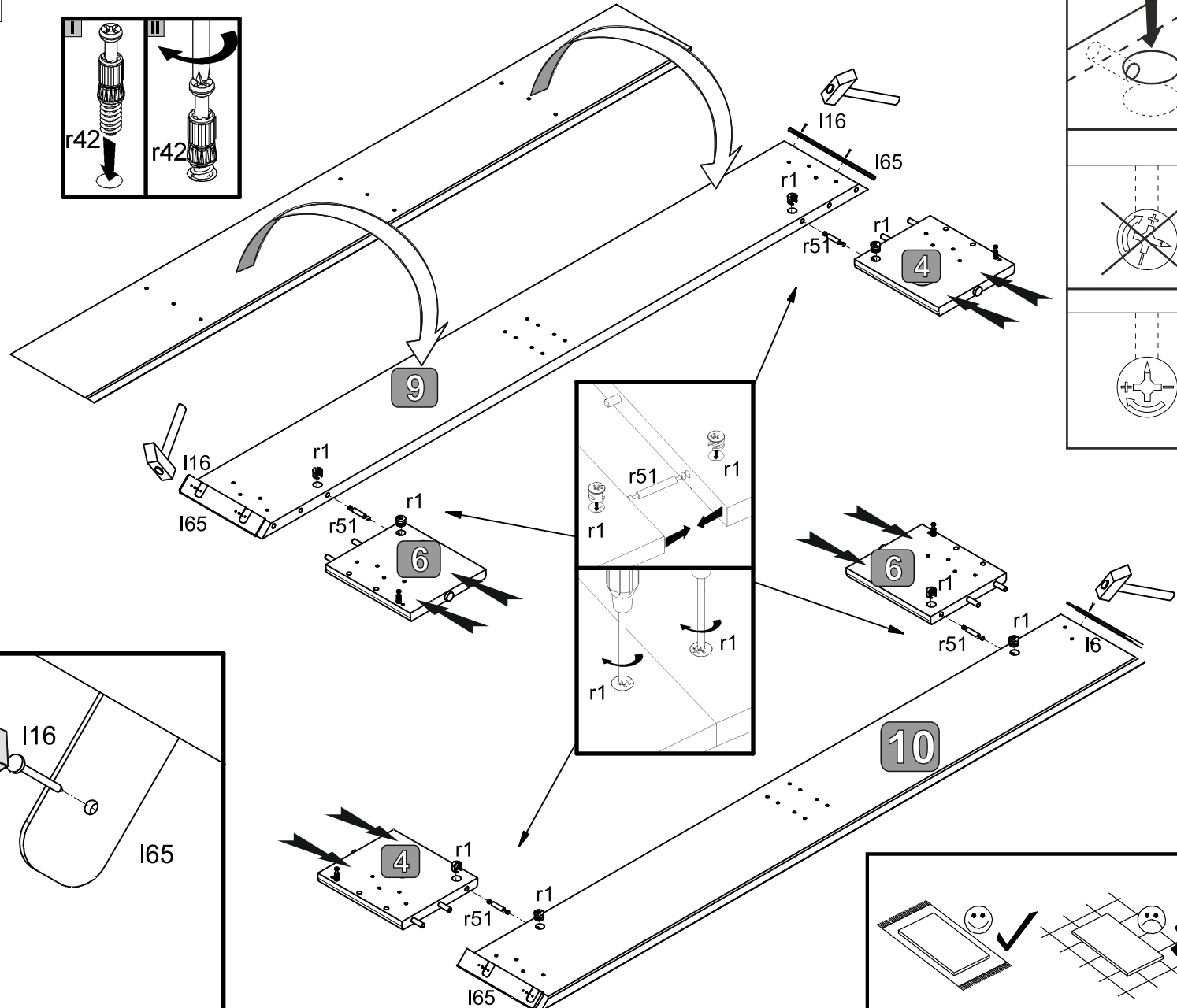
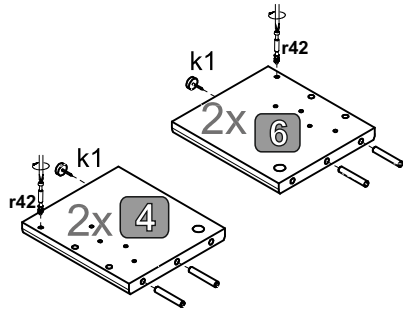
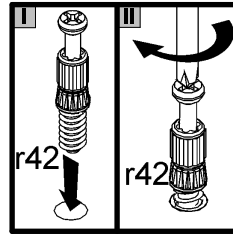
- 8x 1x12 mm I16
- 4x 182 mm I65
- 4x 40 mm r51
- 4x r42
- 8x Ø8x50 mm f6
- 4x k1
- 8x Ø15x12 mm #16 r1



2

- 8x  f1
- 4x  k1
- 8x  f6

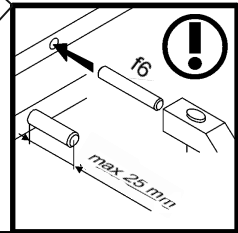
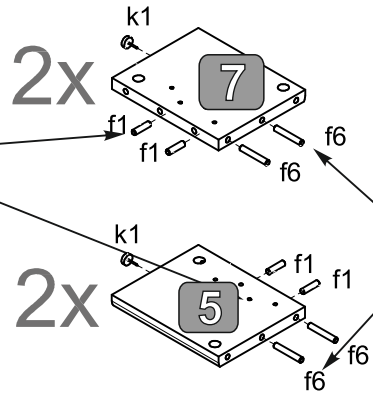
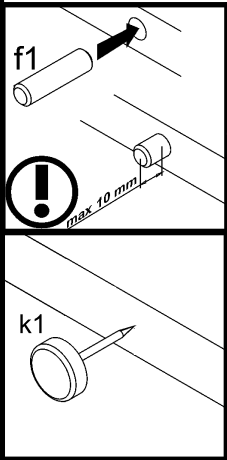

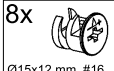

3

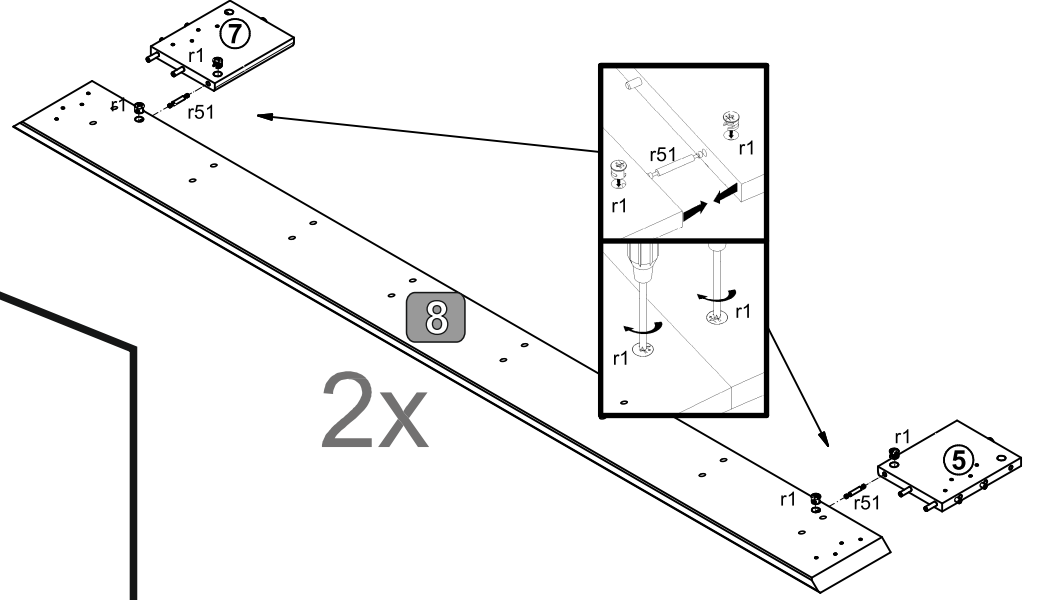
- 4x  r51
- 8x  r1



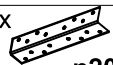

4

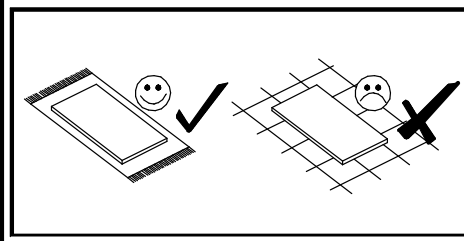
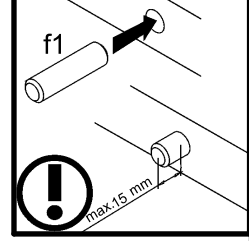
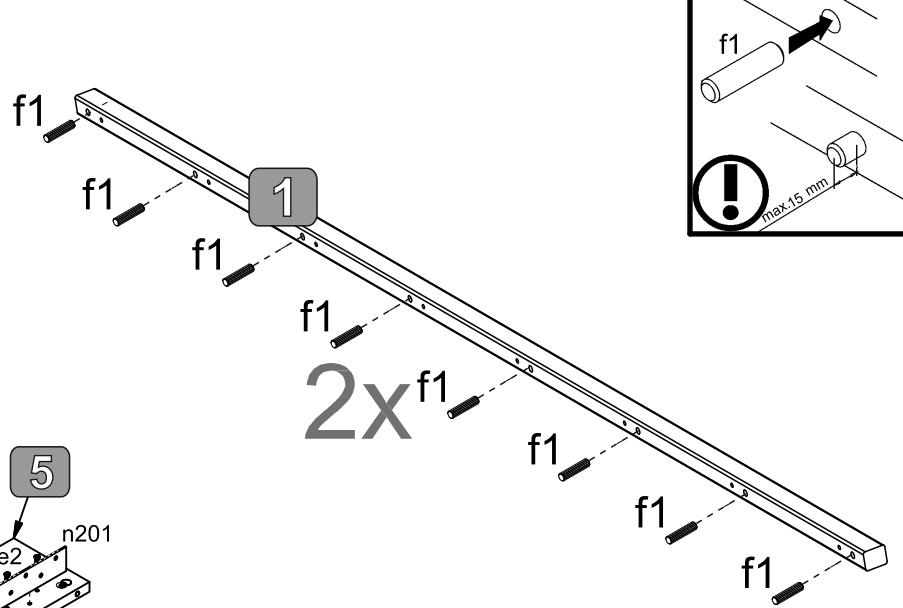
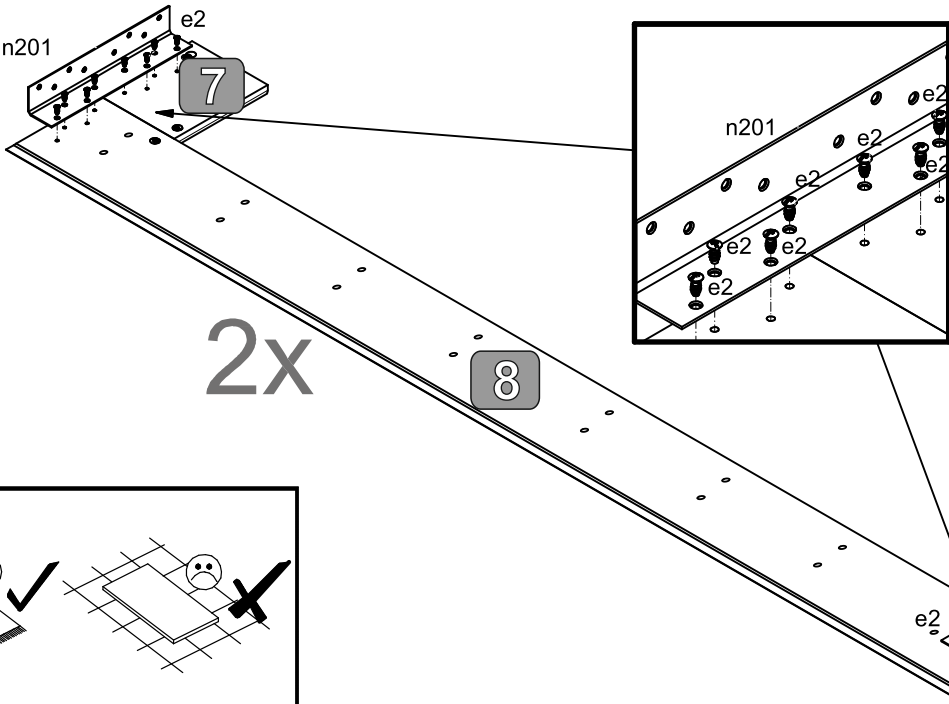
- 4x  n201
- 32x  e2
- 16x  f1



5

- 32x  e2
Ø6.3x13 mm
- 4x  r1
Ø15x12 mm #16

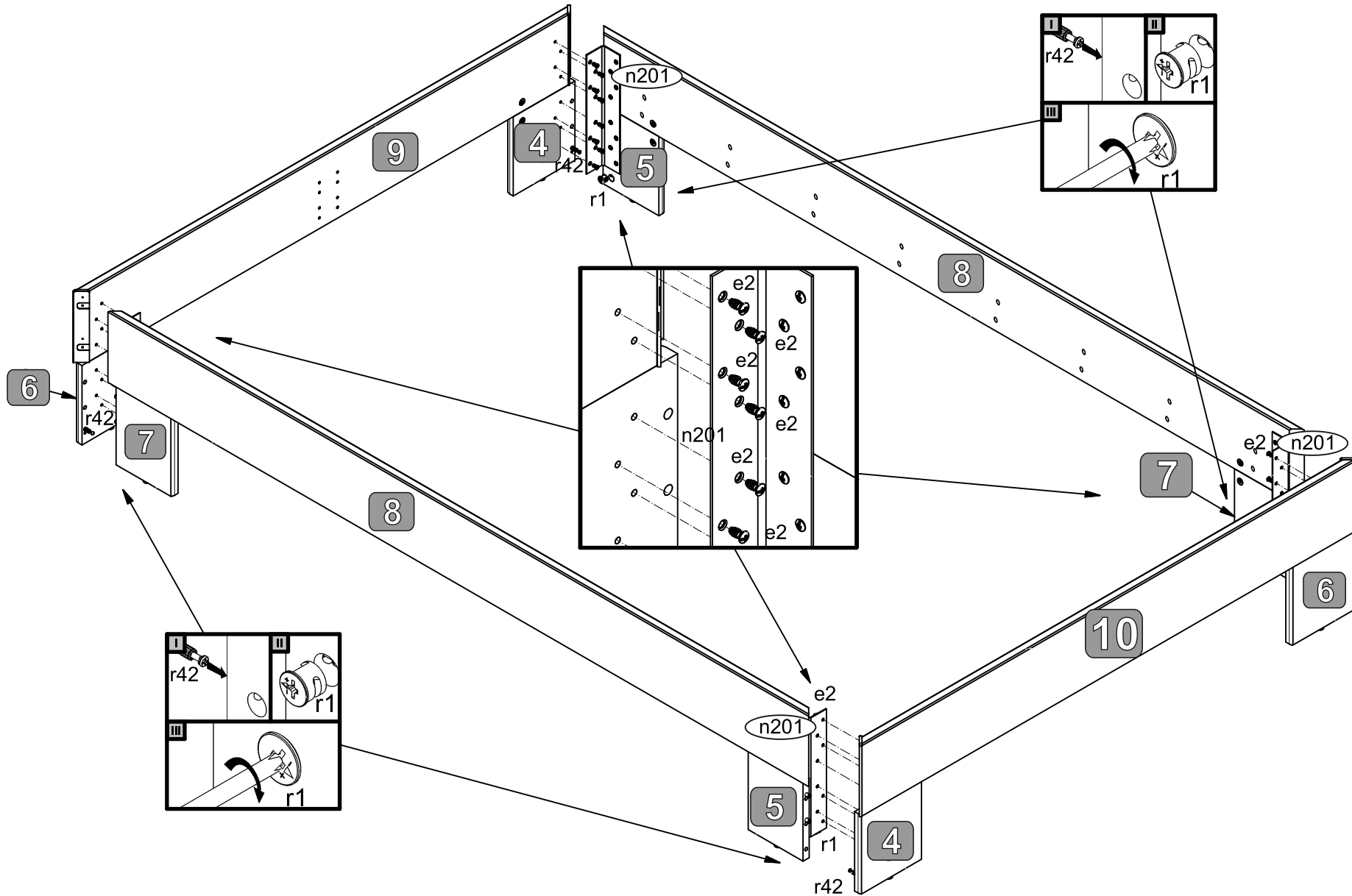

6

- 4x p62
- 2x k24/4
- 2x k24/2
- 2x k24/3
- 2x n34/12
- 6x p16

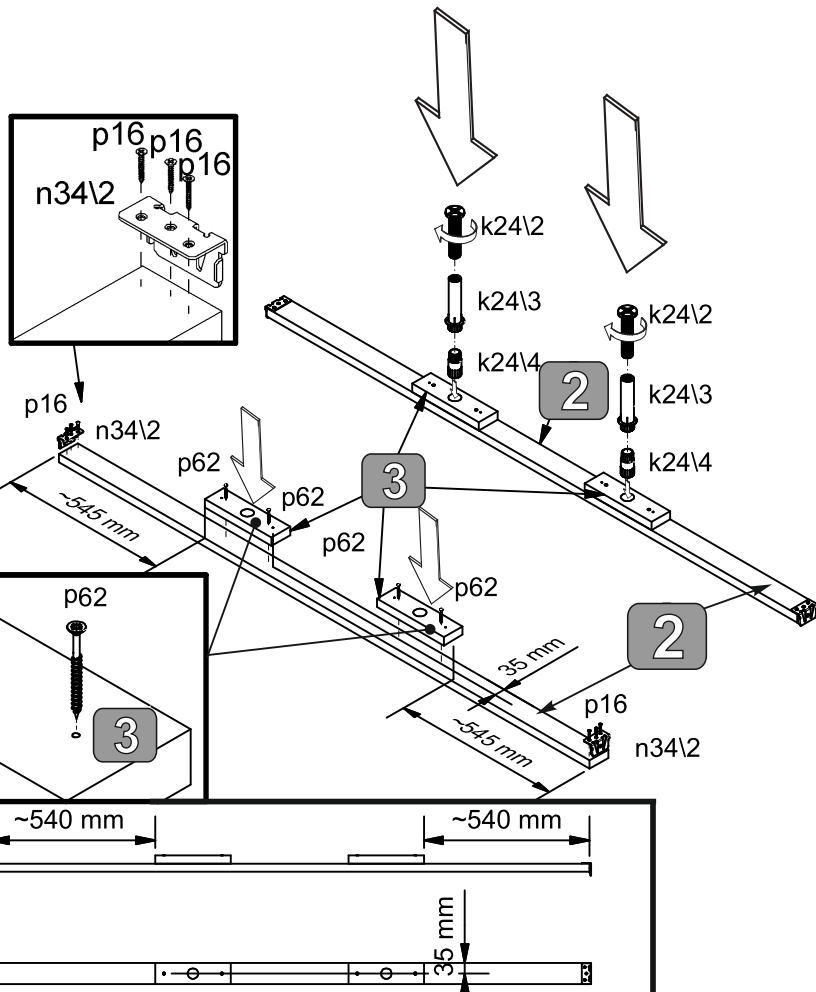

7

- 8x e3
- 16x p11
- 2x n34/1

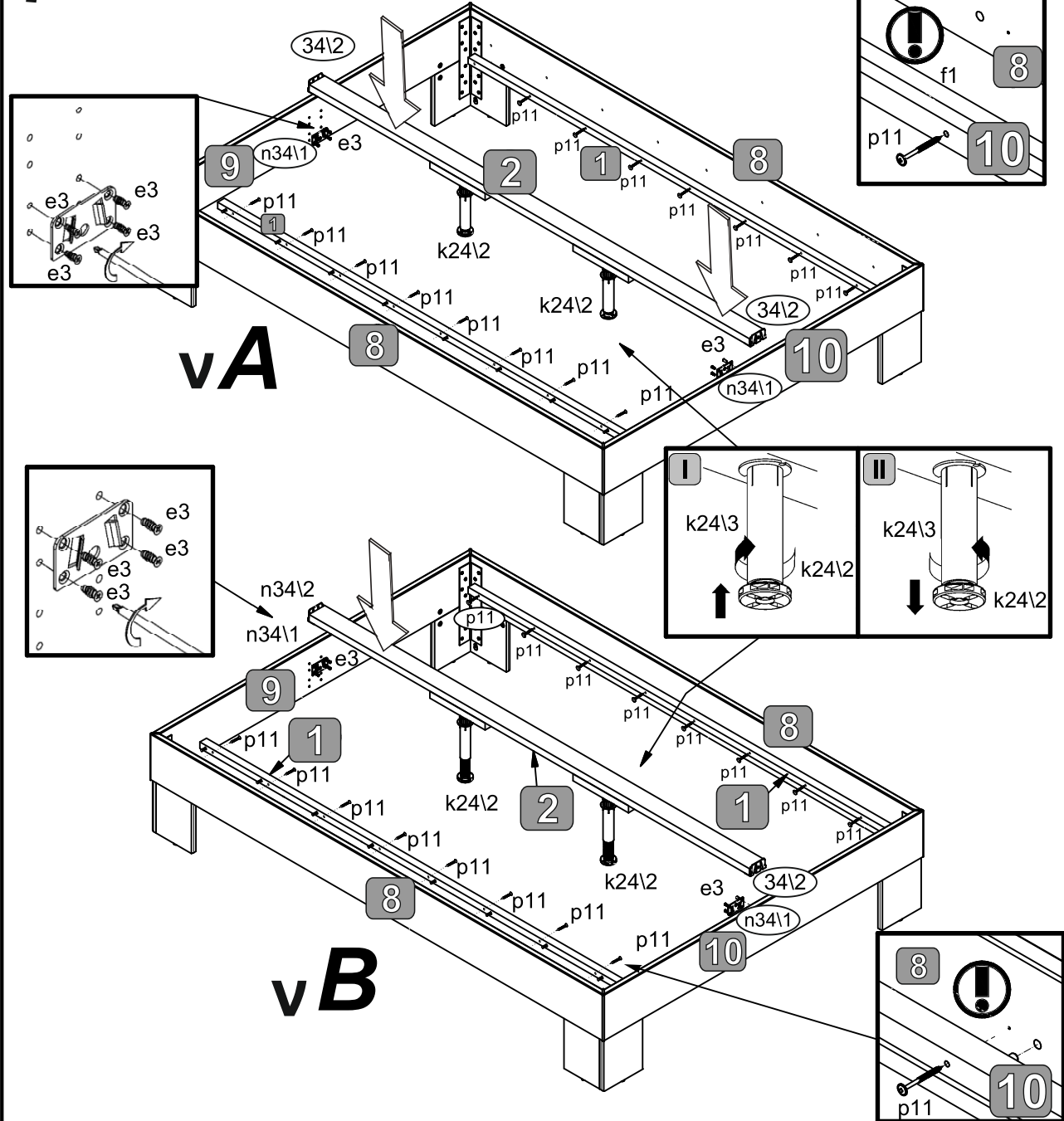

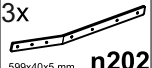
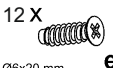
- 8 3x  n202 599x40x5 mm
- 12 x  e20 Ø6x20 mm

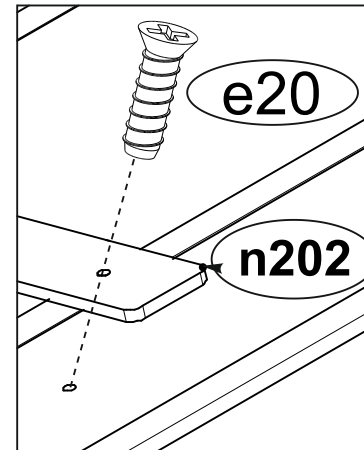
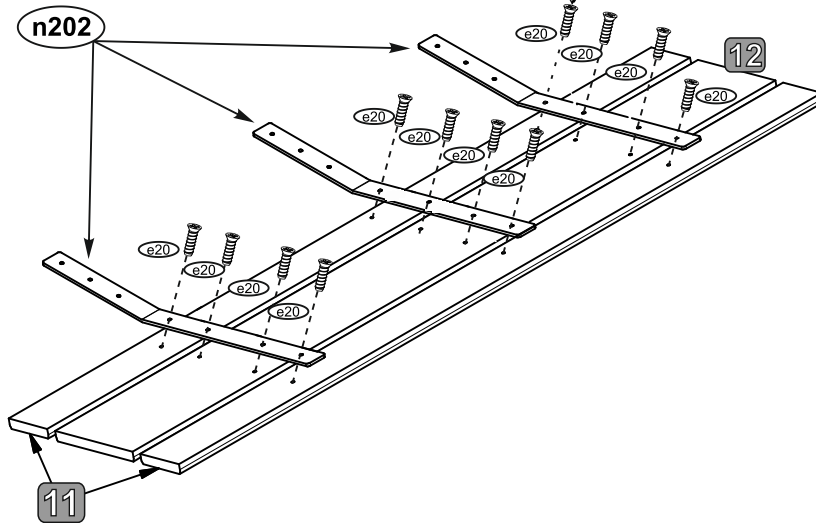

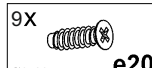
- 9 9x  e20 Ø6x20 mm

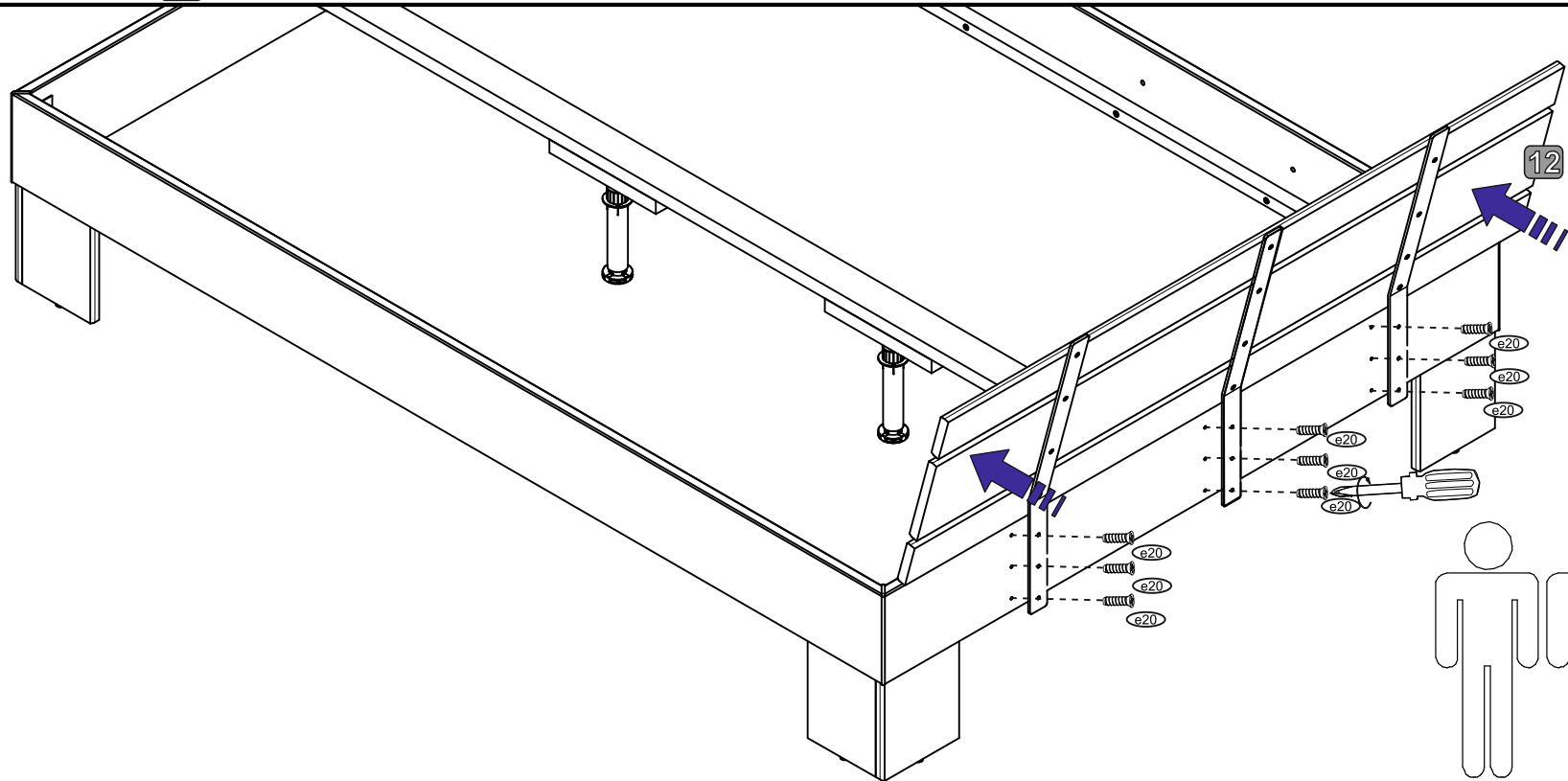

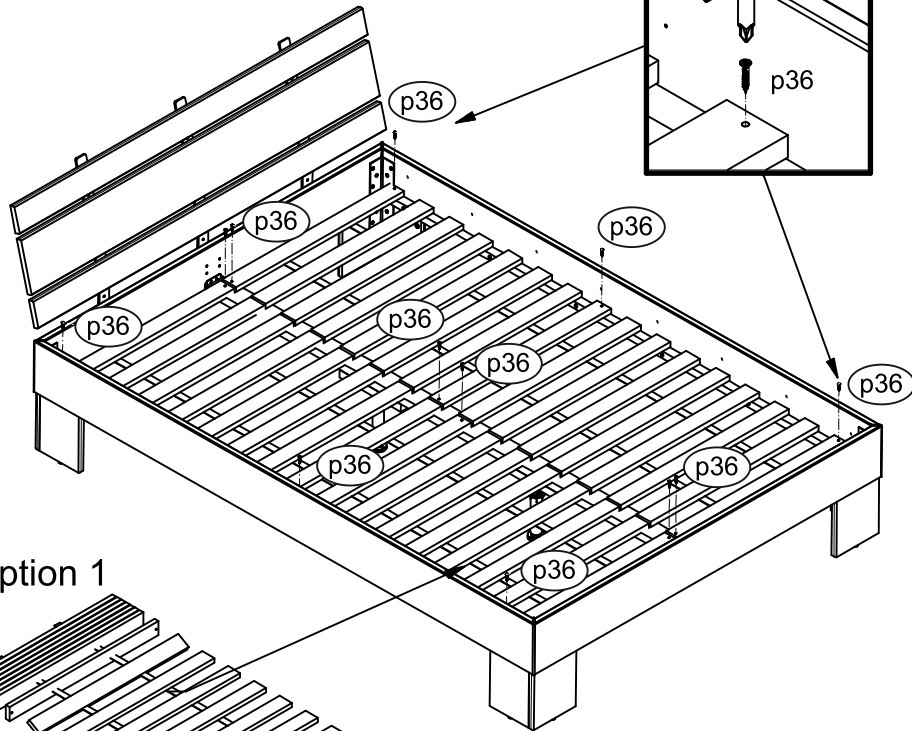
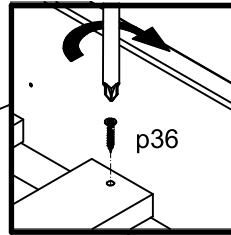

Option 1

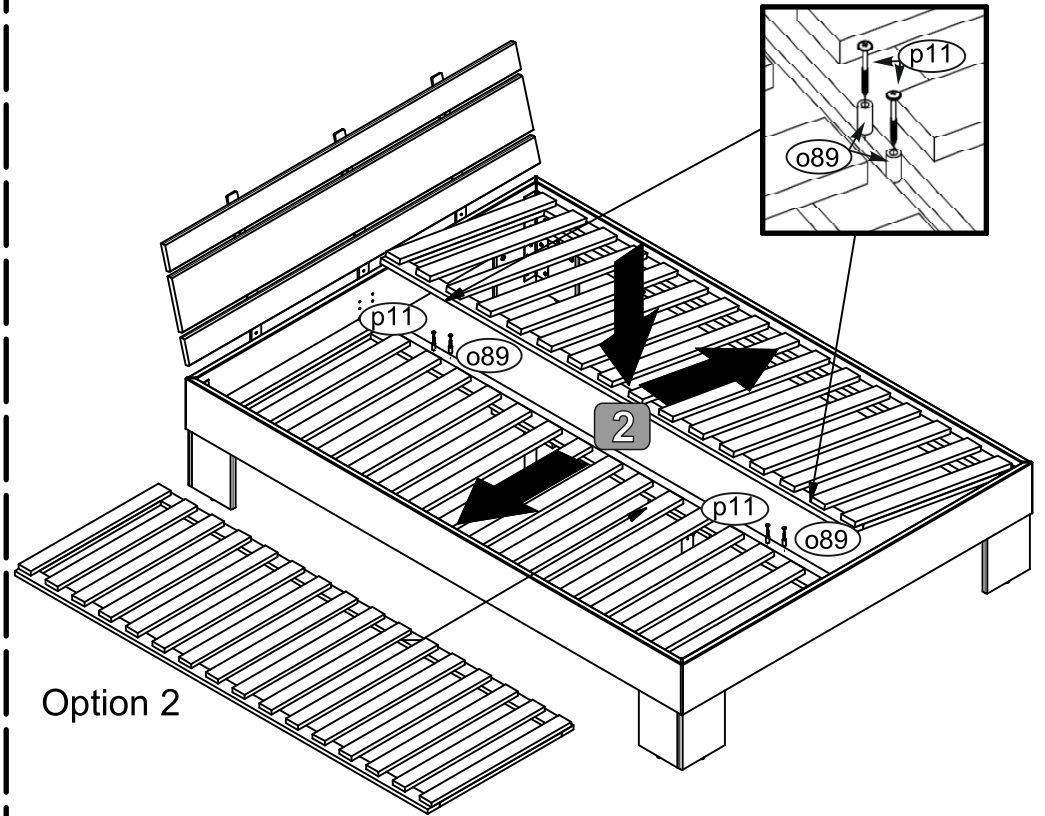
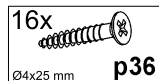
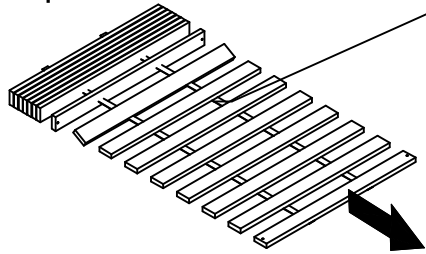

Option 2

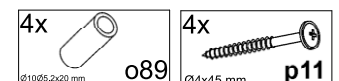
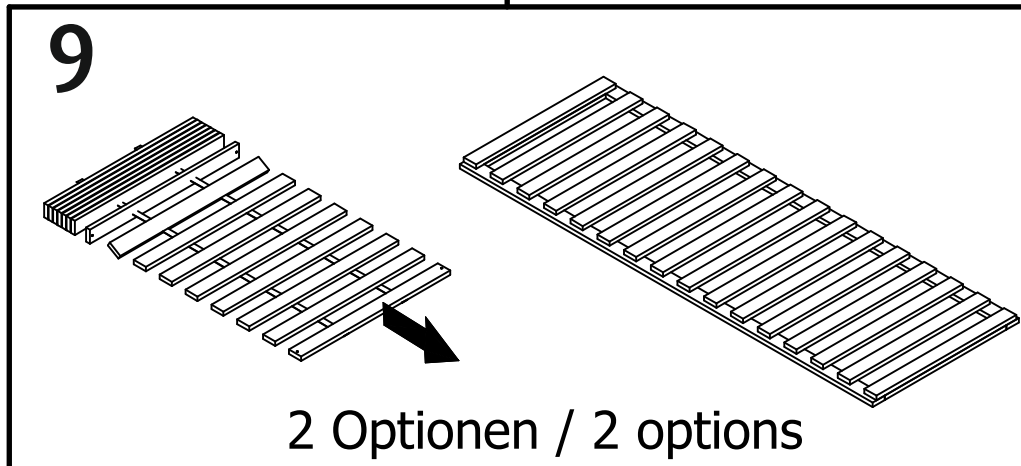

Sicherheitshinweise und Warnungen / Safety notice

DE WICHTIG! FÜR SPÄTERES NACHSCHLAGEN AUFBEWAHREN: SORGFÄLTIG LESEN

WARNUNG: Kleinteile, Verpackungsbeutel und Folien aufgrund von Erstickungsgefahr und möglichem Verschlucken von Babys und Kleinkindern fernhalten!

Um die Gefahr einer Erstickung zu vermeiden, sind Kunststoffhüllen vor dem Gebrauch zu entfernen. Die Hüllen sind zu vernichten oder von Kindern fernzuhalten - Bitte beachten Sie unbedingt die Montageanleitung und bewahren Sie diese auf. Bei einer fehlerhaften Montage können wir keine Haftung übernehmen. Nutzen Sie den Ankel nicht, wenn ein konstruktives Bauteil leicht oder aufgrund einer Beschädigung in seiner Stabilität beeinträchtigt ist. Bei Nichtbeachtung, Änderungen am Produkt oder der Verwendung von nicht originalen Teilen entfallen jegliche Gewährleistung bzw. Haftungsansprüche. Unser Sortiment ist ausschließlich für den privaten Gebrauch konzipiert. Bei vielen Artikeln ist die Montageanleitung eine Wandfestigung vorgesehen. Sollten Dübel/Schrauben beiliegen, sind diese ausschließlich für festes Mauerwerk geeignet. Informieren Sie sich vor der Wandmontage über das geeignete Montagematerial für Ihre Wand und tauschen Sie es ggf. aus. Achten Sie auf den Verlauf von wasser- oder stromführenden Leitungen.

- Elektrikkomponenten, die nicht über eine Steckdose mit dem Stromnetz verbunden werden, dürfen nur von entsprechend geschultem Fachpersonal vorgenommen werden (z.B. Beleuchtungen im Badezimmer, Herdanschlüsse in der Küche). Für alle Elektrikkomponenten liegt eine separate Anleitung bei. Bitte beachten Sie diese unbedingt: Einleitende LED - Beleuchtungen dürfen deklarativ Zwickeln und sind nicht für die Hauptbeleuchtung eines Raums geeignet.

- Überprüfen Sie in regelmäßigen Zeitabständen die Schraubverbindungen und ziehen Sie diese ggf. nach. Beachten Sie die Belastungsangaben in der Montageanleitung. Sollten in der Montageanleitung zusätzliche Sicherungsmaßnahmen für eine sichere Wandfestigung vorgeschrieben sein, müssen diese unbedingt montiert werden (z. B. Wandregale, Große Hängeschränke, ...).

- Neue Möbel werden in der Regel einen typischen Geruch haben. Der Neumoibegeruch wird durch die Freisetzung verschiedenster flüchtiger Stoffe aus den verwendeten Materialien in geringsten Konzentrationen erzeugt. Diese Stoffe werden nicht nachgelassen und vermindern sich nach entsprechendem Auslüften innerhalb kurzer Zeit von selbst. Achten Sie auf eine durchschnittliche Raumtemperatur von ca. 18-23 Grad Celsius und einer Raumluftfeuchte zwischen 40 - 55% und lüften Sie regelmäßig, um einer Schimmelbildung vorzubeugen. Wenden und drehen Sie die Matratzen regelmäßig, um einer Kühlenbildung vorzubeugen.

- Reinigen Sie Möbel mit leicht feuchten Baumwolltüchern. Vermeiden Sie Microfasertücher und Reinigungsmittel mit scheuenden oder lösendemittelhaltigen Zusätzen. Entfernen Sie stehende Feuchtigkeit umgehend.

- Hinweis: Um Matratz auf dem Fußboden zu vermeiden bitte die Polstermöbel vorsichtig anheben, NICHT schieben, kippen oder ziehen.

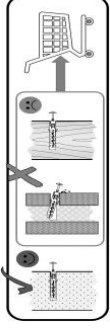
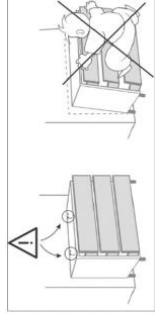

GB IMPORTANT! RETAIN FOR FUTURE REFERENCE. READ CAREFULLY

WARNING: Keep small parts, packaging bags, and films out of reach of babies and toddlers due to the risk of suffocation and possible swallowing!

To avoid the risk of suffocation, plastic covers should be removed before use. Destroy or keep covers away from children.

- Please strictly follow the assembly instructions and keep them for future reference. We cannot accept any liability for incorrect assembly. Do not use the item if any structural component is missing or damaged, compromising its stability. Failure to comply, modifications to the product, or the use of non-original parts will void any warranty or liability claims. Our range is designed exclusively for private use. According to the assembly instructions, many items require wall mounting. If dowels/screws are included, they are only suitable for solid masonry. Inform yourself about the suitable mounting material for your wall before mounting and replace it if necessary. Pay attention to the layout of water or electrical lines.
- Electrical components that are not connected to the power grid via a socket should only be installed by appropriately trained professionals (e.g., lighting in bathrooms, stove connections in kitchens). A separate manual is included for all electrical components. Please be sure to follow it. Included LED lighting is for decorative purposes and is not suitable for the main lighting of a room.
- Regularly check screw connections and tighten them if necessary. Observe the load specifications in the assembly instructions. If additional safety screws are provided in the manual, they must be installed (e.g., wall shelves, large hanging cabinets, etc.).
- New furniture typically emits a characteristic odor. The new furniture smell is caused by the release of various volatile substances from the materials used in very small concentrations. These substances are not regenerated and dissipate on their own after adequate airing within a short time. Maintain an average room temperature of approximately 18-23 degrees Celsius and a room humidity level between 40-55%, and ventilate regularly to prevent mold formation. Turn and rotate mattresses regularly to prevent indentations. Clean the furniture with slightly damp cotton cloths. Avoid microfibre cloths and cleaning agents with abrasive or solvent-containing additives. Remove standing moisture immediately.
- Note: To avoid scratches on the floor, carefully lift upholstered furniture. Do NOT push, tilt, or drag.

FR IMPORTANT! À CONSERVER POUR TOUTE CONSULTATION ULTÉRIEURE. À LIRE ATTENTIVEMENT

MISE EN GARDE: Gardez les petites pièces, les sacs d'emballage et les films hors de portée des bébés et des tout-petits en raison du risque d'étouffement et de possible ingestion!

Pour éviter le risque d'étouffement, les couvertures en plastique doivent être retirées avant utilisation. Détruisez les couvertures ou gardez-les hors de portée des enfants.

- Veuillez suivre strictement les instructions de montage et les conserver pour référence future. Nous ne pouvons accepter aucune responsabilité en cas de montage incorrect. N'utilisez pas l'article si un composant, structural manque ou est endommagé, compromettant sa stabilité. Le non-respect des instructions, les modifications du produit ou l'utilisation de pièces non originales annuleront toute garantie ou réclamation de responsabilité. Notre gamme est exclusivement conçue pour un usage privé. Selon les instructions de montage, de nombreux articles nécessitent une fixation murale. Si des chevilles/vis sont incluses, elles ne sont adaptées qu'à la maçonnerie solide. Informez-vous sur le matériau de montage approprié pour votre mur avant de procéder au montage et remplacez-le si nécessaire. Faites attention à l'emplacement des conduites d'eau ou électriques.
- Les composants électriques qui ne sont pas connectés au réseau électrique via une prise doivent être installés uniquement par des professionnels formés (par exemple, éclairage dans les salles de bains, connexions de cuisinière dans les cuisines). Un manuel séparé est inclus pour tous les composants électriques. Veuillez le suivre impérativement. Les éclairages LED inclus sont destinés à des fins décoratives et ne conviennent pas pour l'éclairage principal d'une pièce.
- Vérifiez régulièrement les connexions des vis et serrez-les si nécessaire. Respectez les spécifications de charge dans les instructions de montage. Si des vis de sécurité supplémentaires sont prévues dans les instructions de montage pour une fixation murale sécurisée, elles doivent être installées (par exemple, étagères murales, grands placards suspendus, etc.).
- Les nouveaux meubles dégagent généralement une odeur caractéristique. L'odeur des meubles neufs est causée par la libération de diverses substances volatiles provenant des matériaux utilisés, en très petites concentrations. Ces substances ne sont pas régénérées et se dissipent d'elles-mêmes après une aération adéquate en peu de temps. Maintenez une température ambiante moyenne d'environ 18-23 degrés Celsius et un taux d'humidité de 40-55%, et aérez régulièrement pour prévenir la formation de moisissures. Retournez et faites pivoter les matelas régulièrement pour éviter les creux. Nettoyez les meubles avec des chiffons en coton légèrement humides. Évitez les chiffons en microfibre et les agents de nettoyage contenant des additifs abrasifs ou des solvants. Éliminez immédiatement l'humidité stagnante.
- Remarque: Pour éviter les rayures sur le sol, soulevez délicatement les meubles/rebroués. Ne poussez PAS, ne basculez PAS, ne tirez PAS.

PL WAŻNE! ZACHOWAĆ DO PÓŹNIEJSZEGO WGLĄDU. PROSZĘ UWAGAŃIE PRZECZYTAĆ

OSTRZEŻENIE: Trzymaj małe części, worki opakowaniowe i folie z dala od niemowląt i małych dzieci ze względu na ryzyko uduszenia i możliwość poknięcia!

Aby uniknąć ryzyka uduszenia, należy przed użyciem usunąć plastikowe osłony. Osłony należy zniszczyć lub trzymać z dala od dzieci.

- Prosimy o ścisłe przestrzeganie instrukcji montażu i zachowanie ich do przyszłego użycia. Nie ponosimy odpowiedzialności za nieprawidłowy montaż. Nie używaj produktu, jeśli brakuje jakiegokolwiek elementu konstrukcyjnego lub jest on uszkodzony, co wpływa na jego stabilność. Nieprzestrzeganie instrukcji, wprowadzanie zmian w konstrukcji, wprowadzanie nieoryginalnych części powoduje utratę gwarancji i wszelkich rozszczeń odszkodowawczych. Nasz asortyment jest przeznaczony wyłącznie do użytku prywatnego. Zgodnie z instrukcją montażu wiele produktów wymaga mocowania do ściany. Jeśli dołączone są kołki/wkręty, są one przeznaczone wyłącznie do mocnego muru. Przed montażem na ścianie sprawdź odpowiedni materiał montażowy do swojej ściany i w razie potrzeby wymień go. Zwróć uwagę na przebieg przewodów wodnych i elektrycznych.
- Elementy elektryczne, które nie są podłączone do sieci elektrycznej za pomocą gniazdka, powinny być instalowane wyłącznie przez odpowiednio przeszkolony personel (np. oświetlenie w łazienkach, podłączenia kuchennek w kuchniach). Do wszystkich elementów elektrycznych dołączona jest osobna instrukcja. Prosimy o jej ścisłe przestrzeganie. Dołączone oświetlenie LED służy celom dekoracyjnym i nie nadaje się do głównego oświetlenia pomieszczenia.
- Regularnie sprawdzaj połączenia śrubowe i w razie potrzeby dokręcaj je. Przestrzegaj obciążień podanych w instrukcji montażu. Jeśli w instrukcji montażu przewidziane są dodatkowe śruby zabezpieczające do bezpiecznego mocowania do ściany, muszą one zostać zastosowane (np. półki ściennie, duże szafki wiszące, itp.).
- Nowe meble zazwyczaj emitują charakterystyczny zapach. Zapach nowych mebli jest spowodowany uwolnieniem różnych lotnych substancji z użytych materiałów w bardzo małych stężeniach. Substancje te nie są regenerowane i niekiedy same po odpowiednim przewietrzeniu w krótkim czasie. Utrzymuj średnią temperaturę w pomieszczeniu na poziomie około 18-23 stopni Celsjusza oraz wilgotność powietrza między 40-55% i regularnie wentyluj pomieszczenia, aby zapobiec powstawaniu pleśni. Regularnie operacja i odwracanie materacy. Regularnie odwracaj i odwracaj materace, aby zapobiec tworzeniu się wgnieceń. Czyść meble lekko wilgotnymi bawełnianymi ściereczkami. Unikaj ściereczek z mikrofibry i środków czyszczących zawierających dodatki ściernie lub rozpuszczalniki. Nieprzeznaczaj, nie basculuj, nie ciągnij.
- Uwaga: Aby uniknąć zarysowań na podłodze, ostrożnie podnoś meble opierając się na nich.

IT IMPORTANTE! CONSERVARE PER CONSULTAZIONE FUTURA. LEGGERE CON ATTENZIONE

ATTENZIONE: Tenere piccole parti, sacchetti di imballaggio e pellicole lontano da neonati e bambini piccoli a causa del rischio di soffocamento e possibile ingestione!

Per evitare il rischio di soffocamento, rimuovere le coperture di plastica prima dell'uso. Distruggi o tieni le coperture lontano dai bambini.

- Si prega di seguire attentamente le istruzioni di montaggio e conservarle per future referenze. Non possiamo accettare alcuna responsabilità per il montaggio errato. Non utilizzare l'articolo se manca un componente strutturale o è danneggiato, compromettendone la stabilità. Il mancato rispetto, le modifiche al prodotto o l'uso di parti non originali annulleranno qualsiasi garanzia o richiesta di risarcimento. La nostra gamma è progettata esclusivamente per uso privato. Secondo le istruzioni di montaggio, molti articoli richiedono il fissaggio a parete. Se sono inclusi tasselli/visi, questi sono adatti solo per muratura solida.

- Informarsi sul materiale di montaggio adatto per la propria parete prima del montaggio e sostituirlo se necessario. Prestare attenzione al percorso delle tubature dell'acqua o dei cavi elettrici.
- I componenti elettrici che non sono collegati alla rete elettrica tramite una presa devono essere installati solo da personale qualificato (ad esempio, illuminazione nei bagni, collegamenti delle cucine). Per tutti i componenti elettrici è inclusa una guida separata. Si prega di seguirlo attentamente. Le illuminazioni a LED incluse sono destinate a scopi decorativi e non sono adatte all'illuminazione principale di una stanza.
- Controllare regolarmente le connessioni delle viti e serrarle se necessario. Osservare le specifiche di carico nelle istruzioni di montaggio. Se nelle istruzioni di montaggio sono previste viti di sicurezza aggiuntive per un fissaggio sicuro alla parete, queste devono essere installate (ad esempio, mensole a muro, grandi armadi sospesi, ecc.).
- I mobili nuovi generalmente emettono un odore caratteristico. L'odore dei mobili nuovi è causato dal rilascio di varie sostanze volatili dai materiali utilizzati in concentrazioni molto basse. Queste sostanze non vengono rigenerate e si dissipano da sole dopo un'adeguata ventilazione in breve tempo. Mantenere una temperatura ambiente media di circa 18-23 gradi Celsius e un'umidità dell'aria tra il 40-55%, e ventilare regolarmente per prevenire la formazione di muffe. Girare e ruotare regolarmente i materassi per evitare la formazione di avvallamenti. Pulire i mobili con panni di cotone leggermente umidi. Evitare panni in microfibra e detersivi contenenti additivi abrasivi o solventi. Rimuovere immediatamente l'umidità stagnante.
- Nota: Per evitare graffi sul pavimento, sollevare con cautela i mobili imbottiti. NON spingere, inclinare o trascinare.

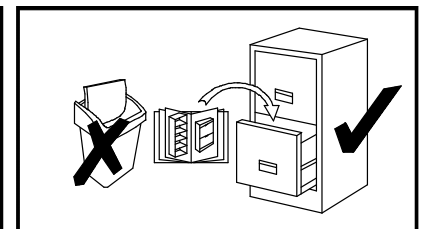
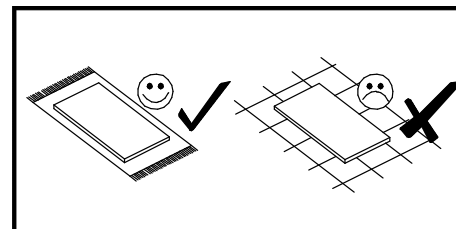
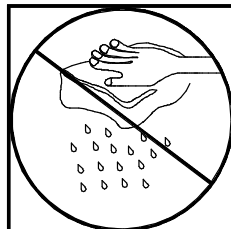
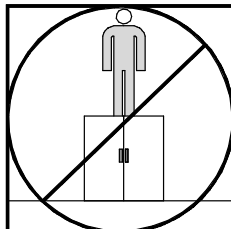
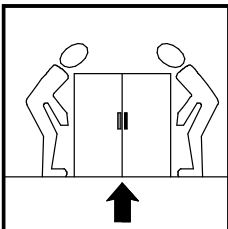
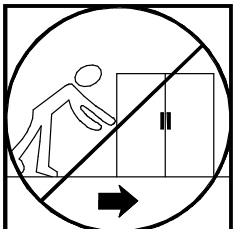
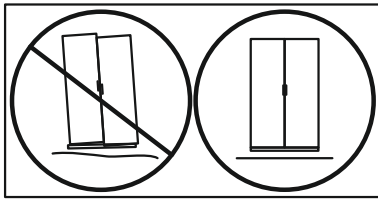
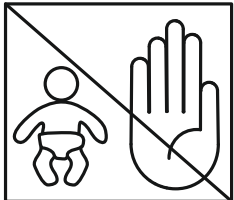
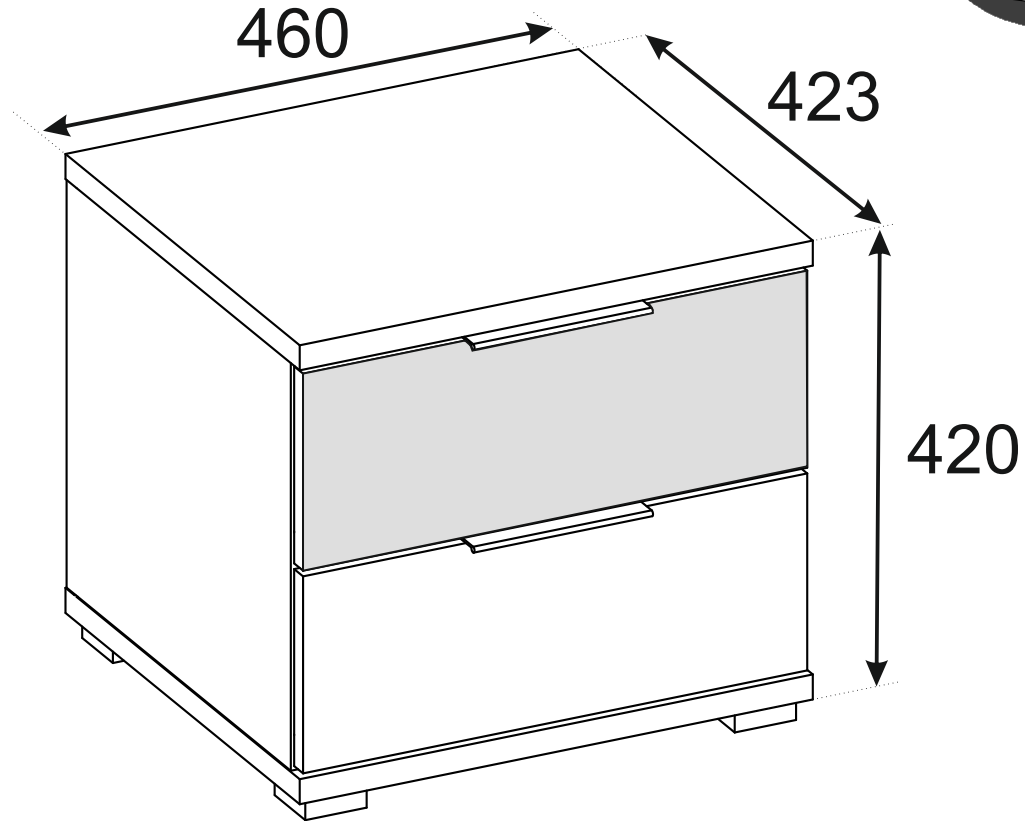
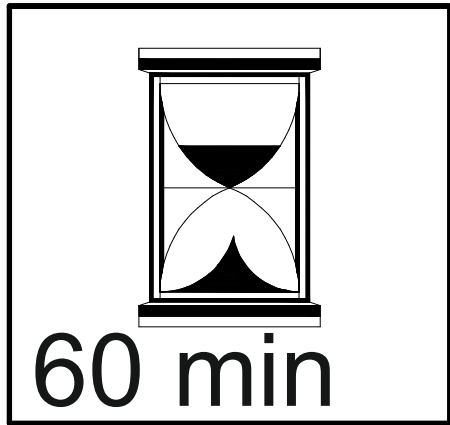
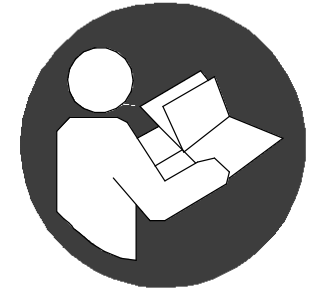
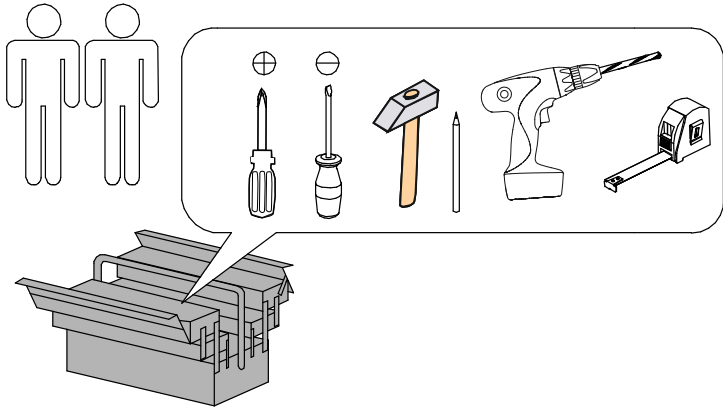

Timbon

38-228-..-I

W8 x8	S2 x4	I1 x1	C1 x4	K1 12x	U2 2x	W3 x4	F3 x4	W9 x16	D4 x4
G1 x30	E4 x1	E2 x1	E1 x2	E3 x1	D3 x4				

NR				ST.
1	350	120	12	2
2	350	120	12	2
3	452	173	16	1
4	452	173	16	1
5	418	357	3	2
6	394	120	12	2
7	460	420	22	1
8	460	420	22	1
9	359	402	16	2
10	445	377	3	1



= x8

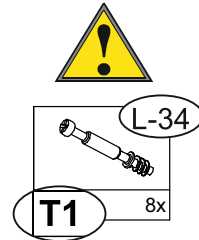

= x8

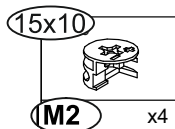



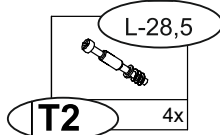

= x4

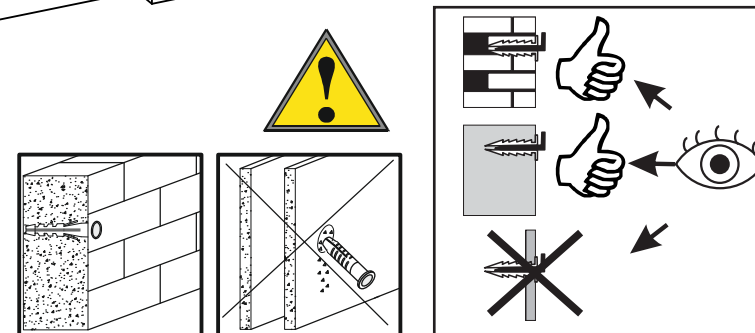
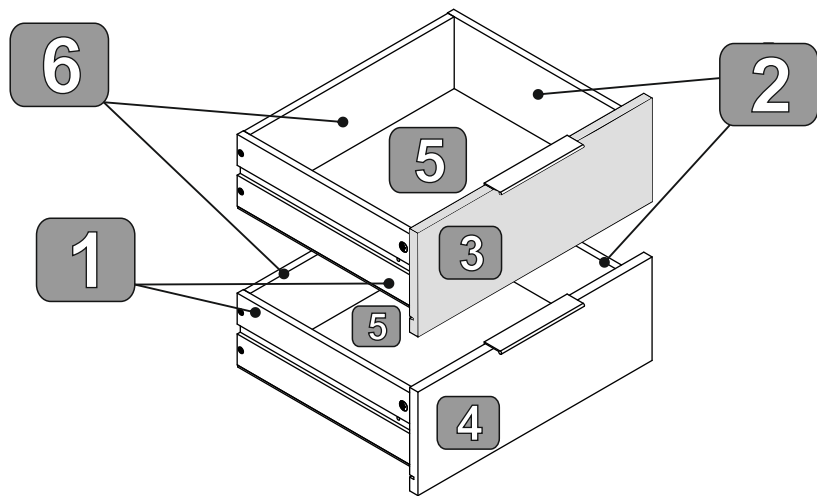
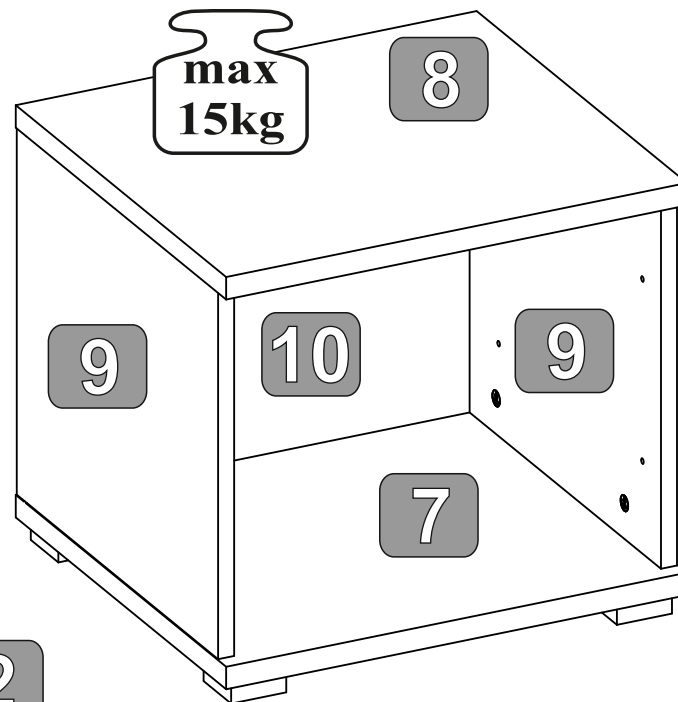

= x4

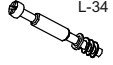

1

					
F3	x4 W9	x4 D4	x4 W8	x8 K1	x8 T1

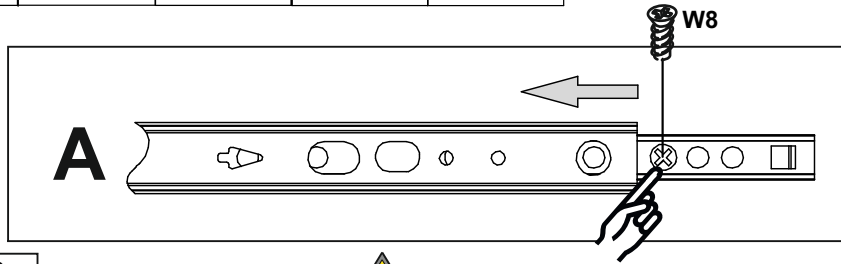

FRONT

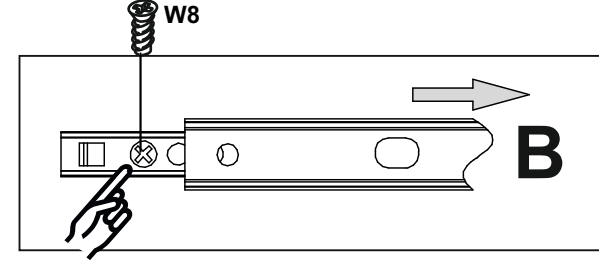

FRONT

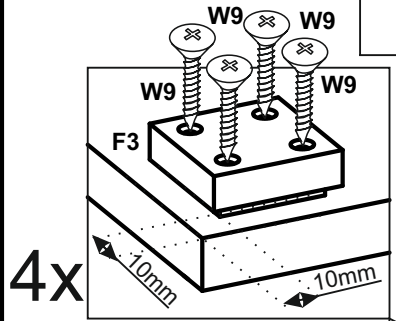

4x

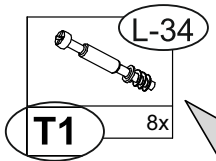

= x8

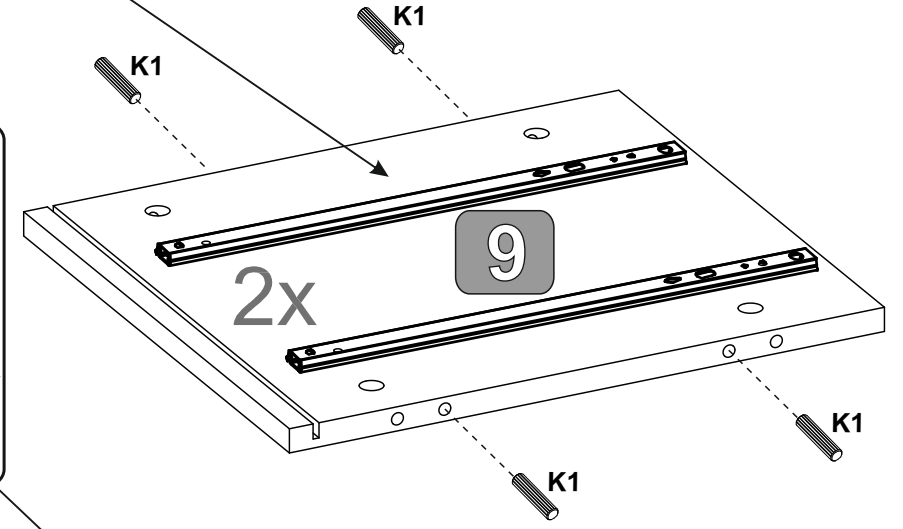
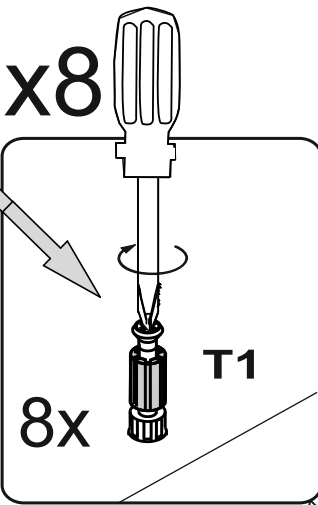

2x

9

8

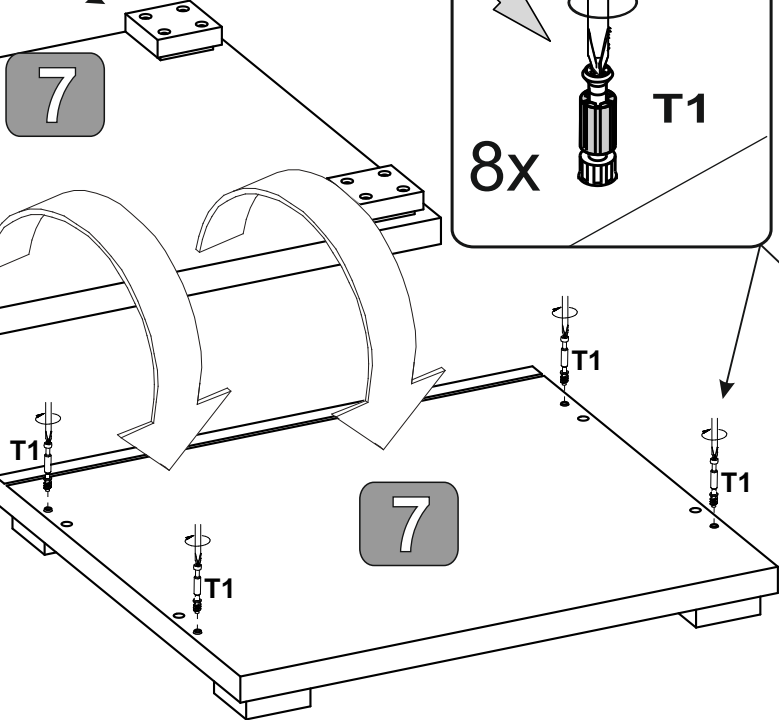

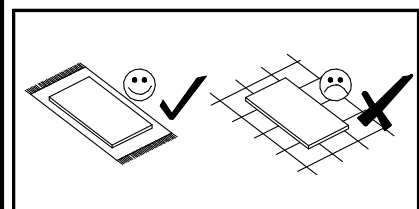

7

7



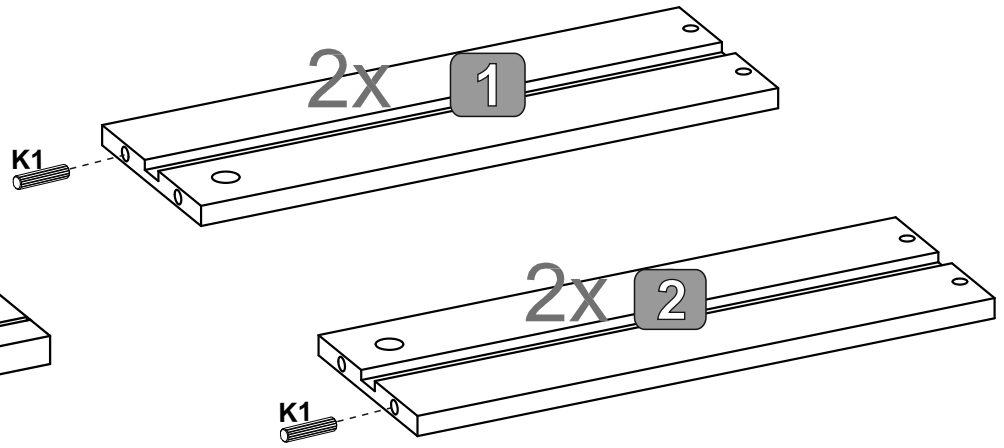
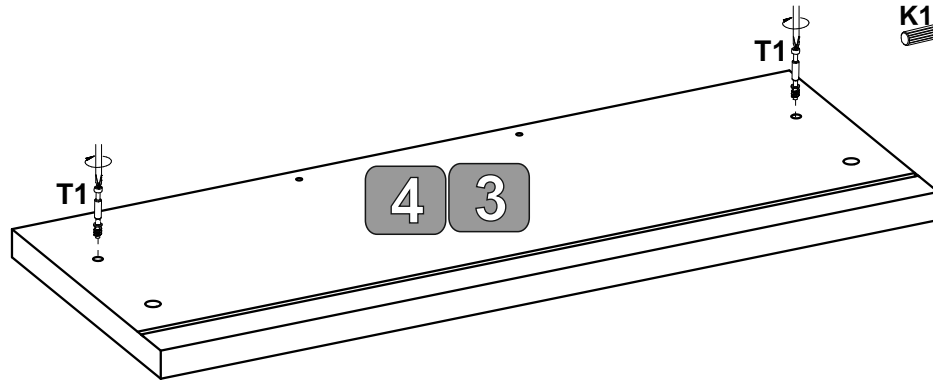

2

 L-28,5	 8x30
T2 4x	K1 x4



3

 7x50		
S2 x4	I1 x1	M2 x4

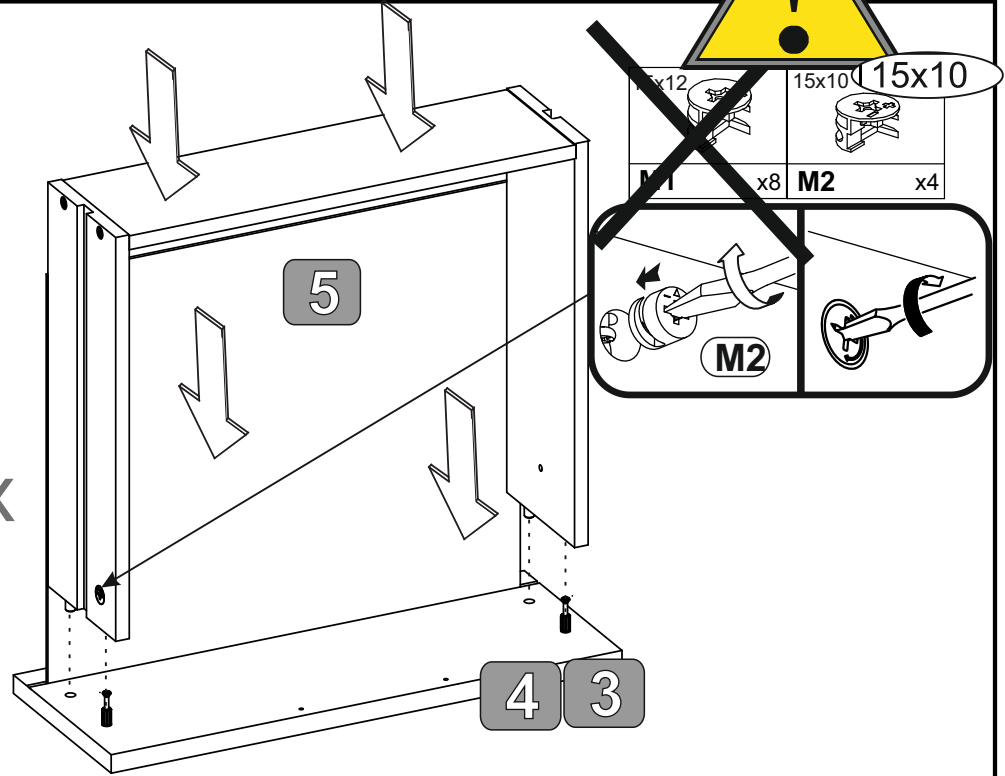
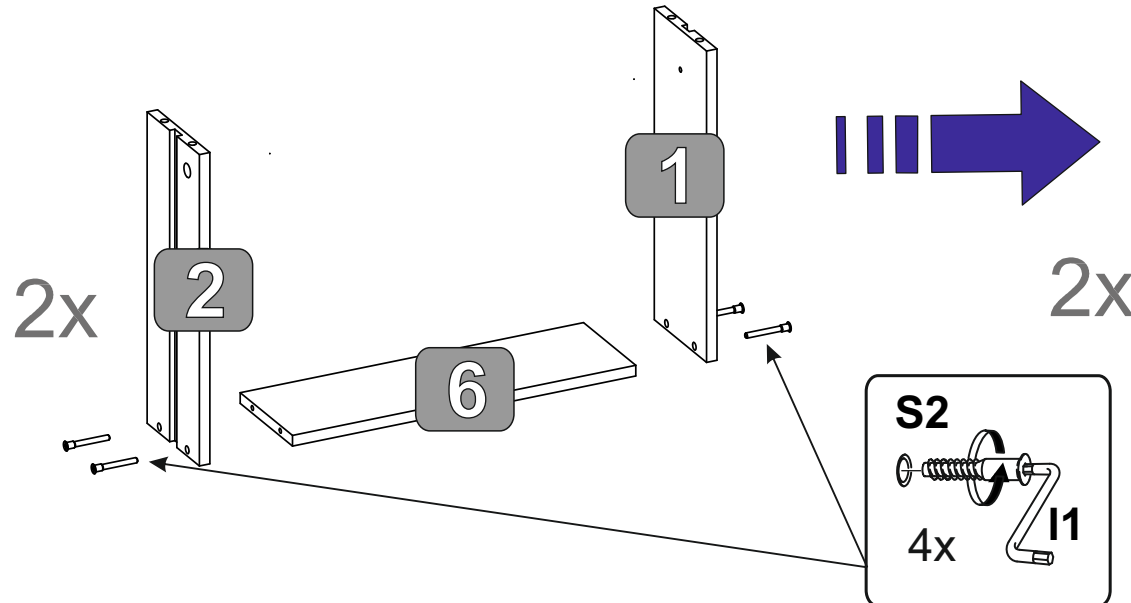

4

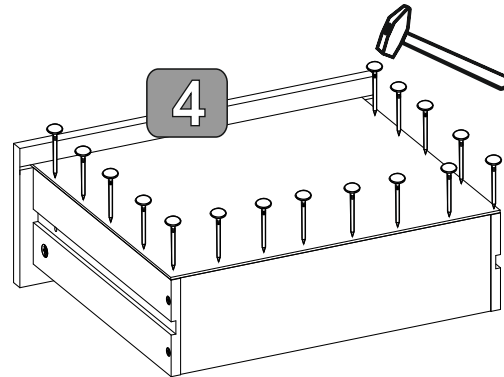
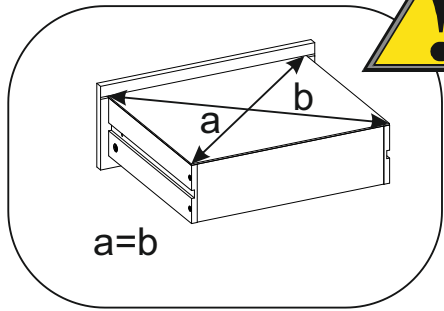
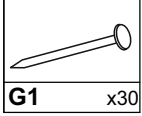

30x

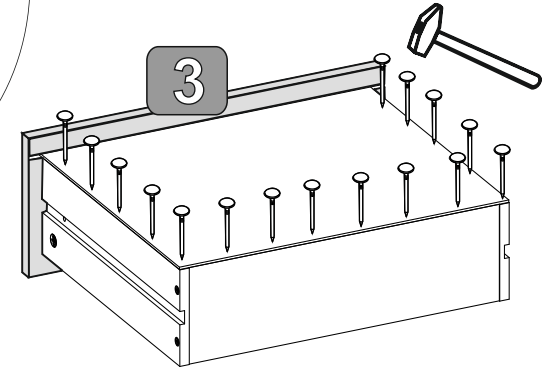
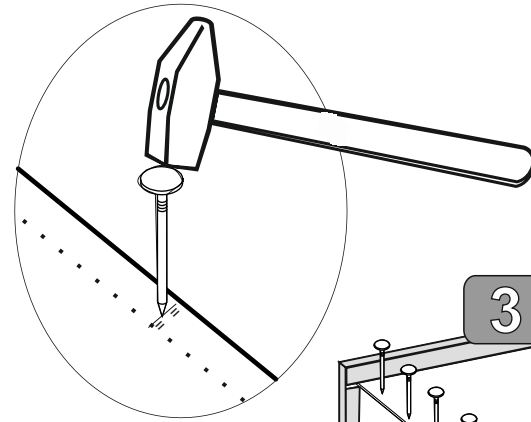

5

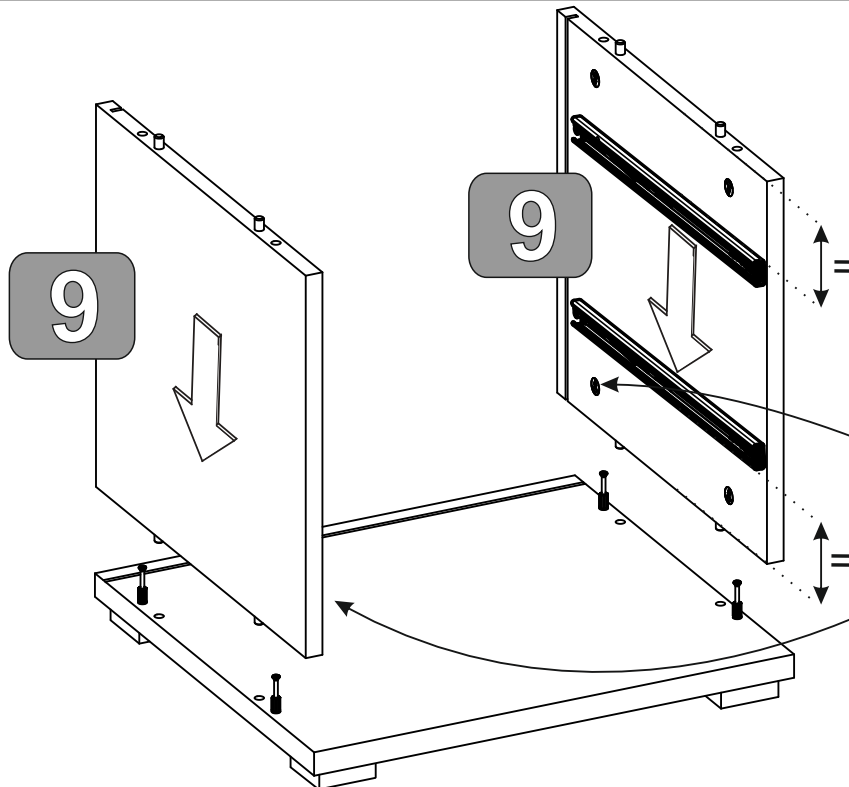
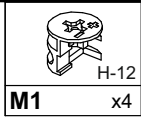

4x

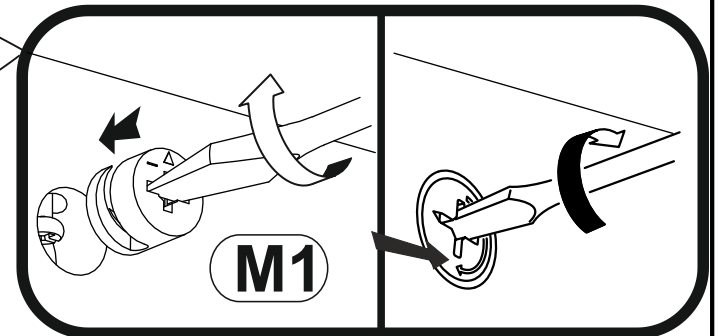

8

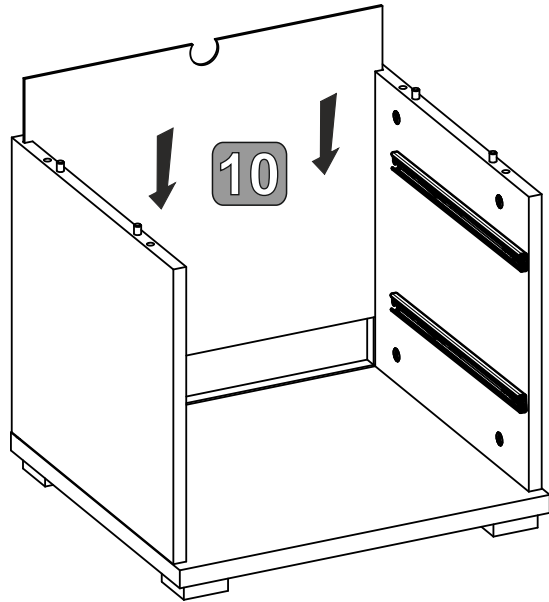

9

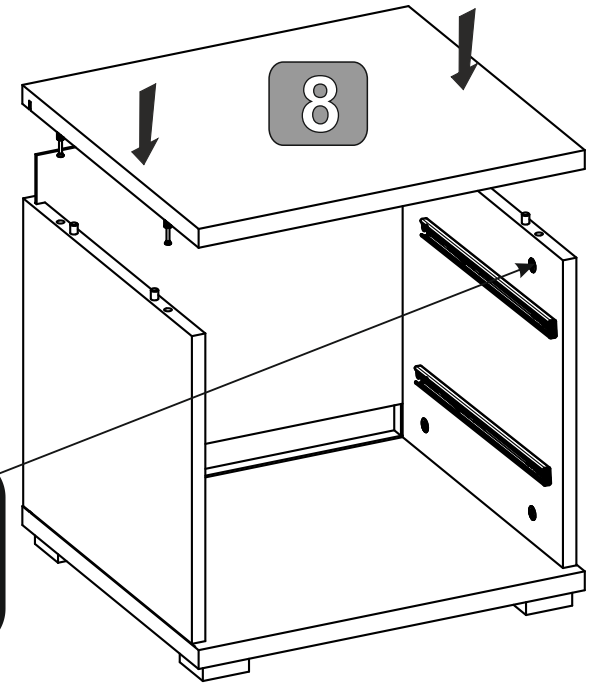
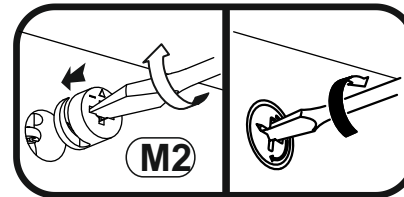
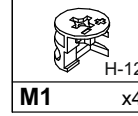

10

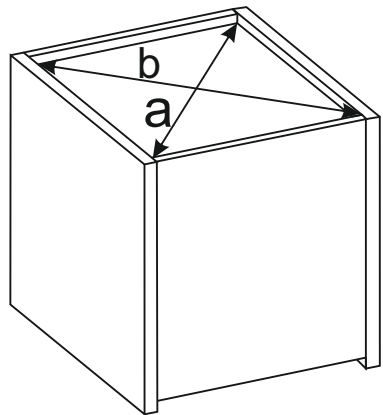
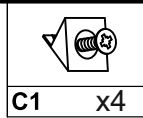



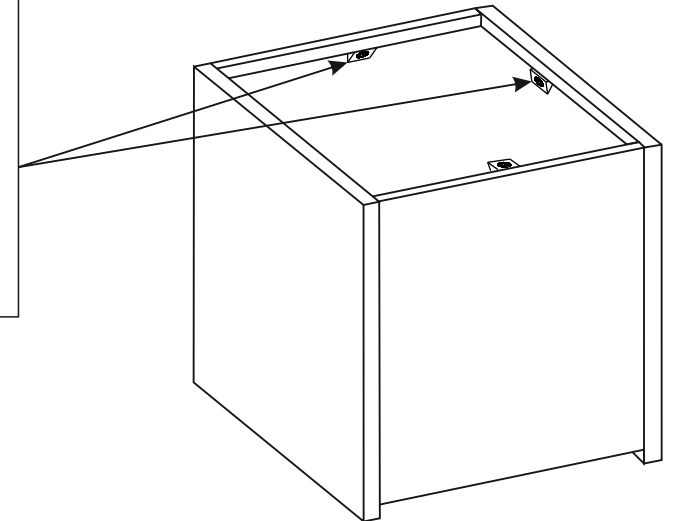
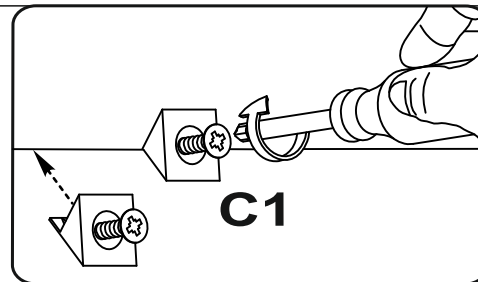
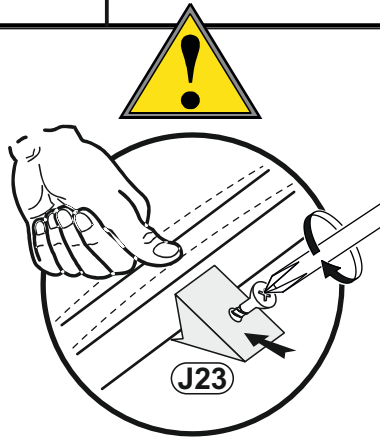

$a=b$

4x



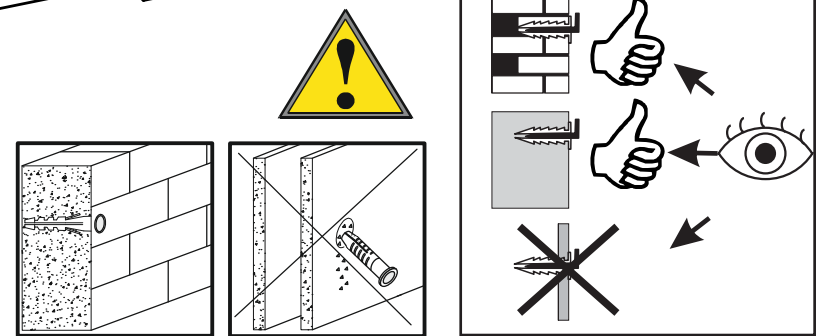
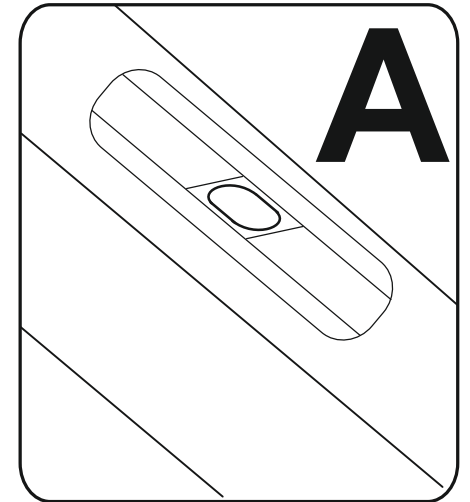
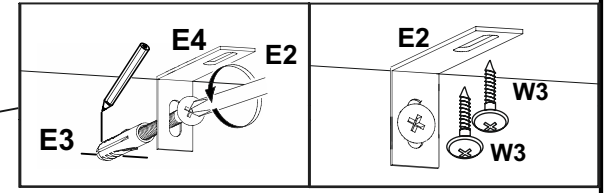
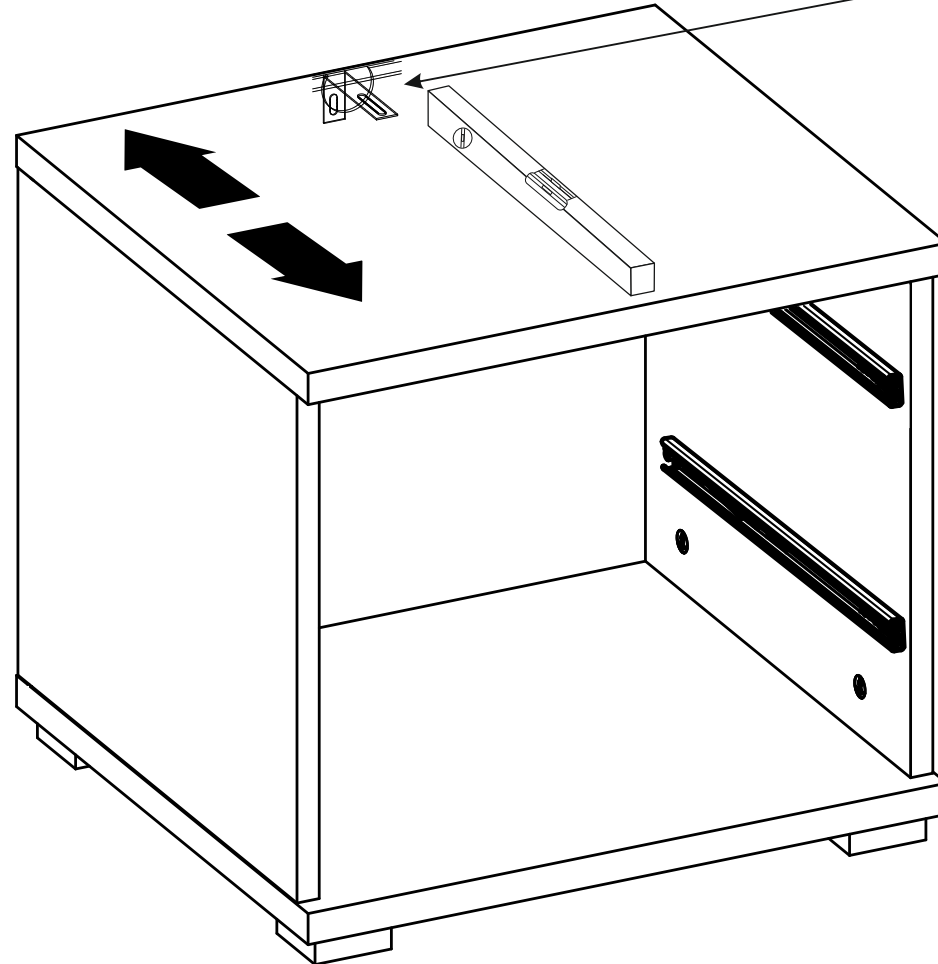
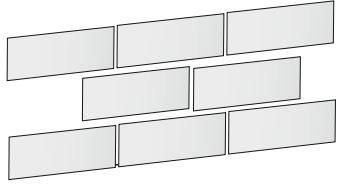
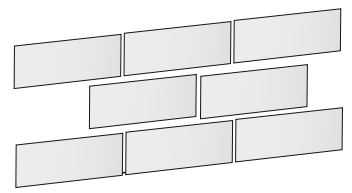

11

			
E4	x1	E1	x2
		4x13	
			E3
			x1



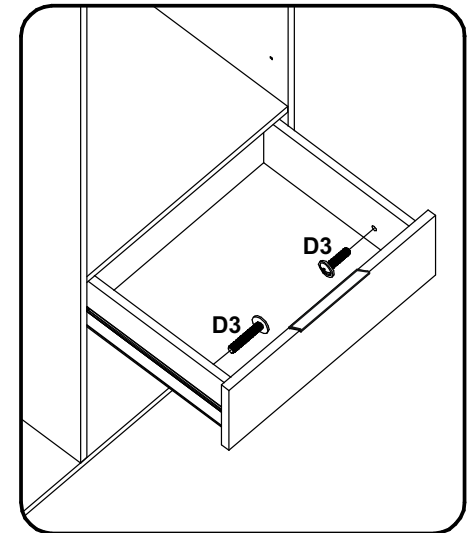
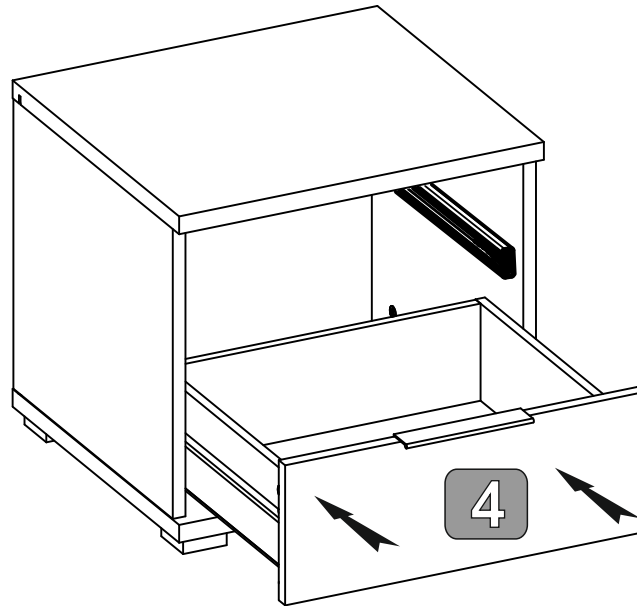
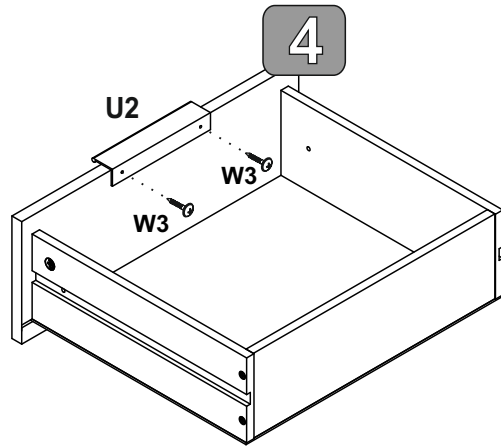

11

	3,5x16		
D3	x2	W3	x2 U2 1x



12

	3,5x16		
D3	x2	W3	x2 U2 1x

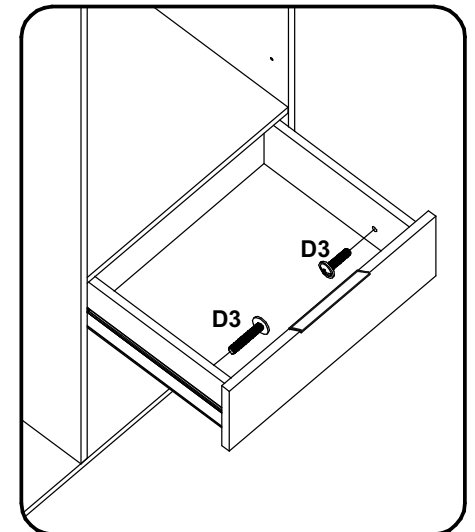
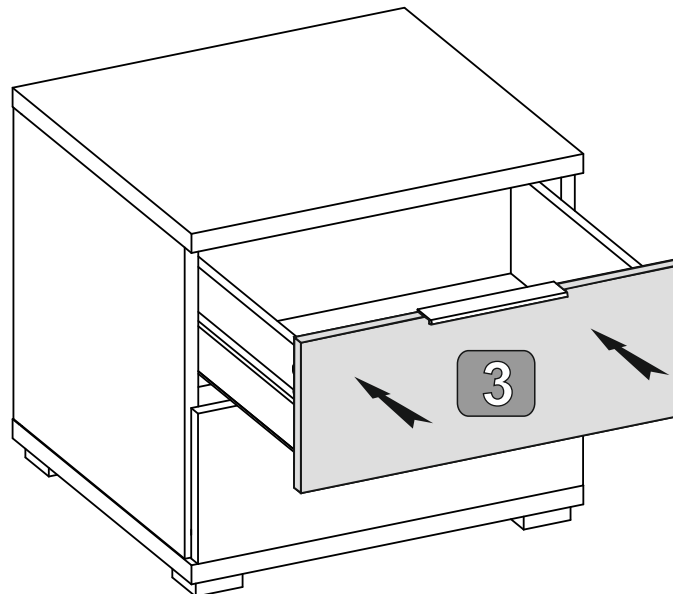
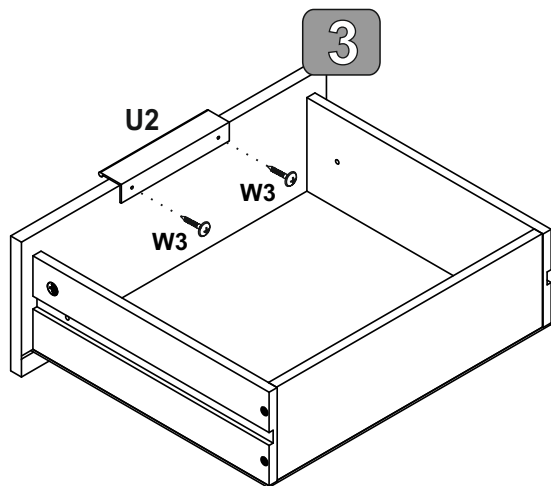

Sicherheitshinweise und Warnungen / Safety notice

DE WICHTIG! FÜR SPÄTERES NACHSCHLAGEN AUFBEWAHREN: SORGFÄLTIG LESEN

WARNUNG: Kleinteile, Verpackungsbeutel und Folien aufgrund von Erststückerfahrung und möglichem Verschlucken von Babys und Kleinkindern fernhalten!

Um die Gefahr einer Erststück zu vermeiden, sind Kunststoffhüllen vor dem Gebrauch zu entfernen. Die Hüllen sind zu vernichten oder von Kindern fernzuhalten. Bitte beachten Sie unbedingt die Montageanleitung und bewahren Sie diese auf. Bei einer fehlerhaften Montage können wir keine Haftung übernehmen. Nutzen Sie den Artikel nicht, wenn ein konstruktives Bauteil fehlt oder aufgrund einer Beschädigung in seiner Stabilität beeinträchtigt ist. Bei Nachbestellung, Änderungen am Produkt oder der Verwendung von nicht originalen Teilen empfehlen wir eine Gewährleistung bzw. Haftungsansprüche. Unser Sortiment ist ausschließlich für den privaten Gebrauch konzipiert. Bei vielen Artikeln ist die Montageanleitung eine Versandleistung, die Sie separat bestellen müssen. Für festes Materialwerkzeug geeignet. Informieren Sie sich vor der Verwendung über das geeignete Material für Ihre Mund und tauschen Sie es ggf. aus. Achten Sie auf den Verlauf von Wasser- oder stromführenden Leitungen. Elektrikkomponenten, die nicht über eine Steckdose mit dem Stromnetz verbunden werden, dürfen nur von autorisierten geschulten Fachpersonal vorgenommen werden (z.B. Beleuchtungen im Badezimmer, Heizanschlüsse in der Küche). Für alle Elektronikkomponenten liegt eine separate Anleitung bei. Bitte beachten Sie diese unbedingt. Entferrnede LED-Beleuchtungen dienen dekorativen Zwecken und sind nicht für die Hauptbeleuchtung eines Raums geeignet. Überprüfen Sie in regelmäßigen Zeitabständen die Schrumpfbänderungen und ziehen Sie diese ggf. nach. Beachten Sie die Belastungsangaben in der Montageanleitung. Sollten in der Montageanleitung zusätzliche Sicherungsmaßnahmen für eine sichere Wandbefestigung vorgeschrieben sein, müssen diese unbedingt montiert werden (z.B. Wandregale, Große Hängeschirme, ...). Neue Möbel vorströmen in der Regel einen typischen Geruch. Der Neumoibegeruch wird durch die Freisetzung verschiedener flüchtiger Stoffe aus den verwendeten Materialien in geringsten Konzentrationen erzeugt. Diese Stoffe werden nicht nachgebildet und verflüchtigen sich nach entsprechendem Auslüften innerhalb kurzer Zeit von selbst. Achten Sie auf eine durchschnittliche Raumtemperatur von ca. 18-23 Grad Celsius und einer Raumluftfeuchte zwischen 40 - 55% und lüften Sie regelmäßig, um einer Schimmelbildung vorzubeugen. Wenden und drehen Sie die Matrizen regelmäßig, um einer Kühlungbildung vorzubeugen. Reinigen Sie Möbel mit leicht feuchten Baumwolltüchern. Vermeiden Sie Microfasertücher und Reinigungsmittel mit Scheuerenden oder lösungsmittelhaltigen Zusätzen. Entfernen Sie stehende Feuchtigkeit umgehend.

- Hinweis: Um Kratzer auf dem Fußboden zu vermeiden bitte die Polstermöbel vorsichtig anheben, NICHT schieben, Kippen oder ziehen.

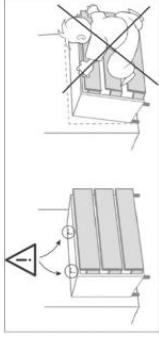

GB IMPORTANT! RETAIN FOR FUTURE REFERENCE. READ CAREFULLY

WARNING: Keep small parts, packaging bags, and films out of reach of babies and toddlers due to the risk of suffocation and possible swallowing!
To avoid the risk of suffocation, plastic covers should be removed before use. Destroy or keep covers away from children.

Please strictly follow the assembly instructions and keep them for future reference. We cannot accept any liability for incorrect assembly. Do not use the item if any structural component is missing or damaged, compromising its stability. Failure to comply, modifications to the product, or the use of non-original parts will void any warranty or liability claims. Our range is designed exclusively for private use. According to the assembly instructions, many items require wall mounting. If dowels/screws are included, they are only suitable for solid masonry. Inform yourself about the suitable mounting material for your wall before mounting and replace it, if necessary. Pay attention to the layout of water or electrical lines.

Electrical components that are not connected to the power grid via a socket should only be installed by appropriately trained professionals (e.g., lighting in bathrooms, stove connections in kitchens). A separate manual is included for all electrical components. Please be sure to follow it. Included LED lighting is for decorative purposes and is not suitable for the main lighting of a room.

Regularly check screw connections and tighten them if necessary. Observe the load specifications in the assembly instructions. If additional safety screws are provided in the assembly instructions for secure wall mounting, they must be installed (e.g., wall shelves, large hanging cabinets, etc.).

New furniture typically emits a characteristic odor. The new furniture smell is caused by the release of various volatile substances from the materials used in very small concentrations. These substances are not regenerated and dissipate on their own after adequate airing within a short time. Maintain an average room temperature of approximately 18-23 degrees Celsius and a room humidity level between 40-55%, and ventilate regularly to prevent mold formation. Turn and rotate mattresses regularly to prevent indentations. Clean the furniture with slightly damp cotton cloths. Avoid microfiber cloths and cleaning agents with abrasive or solvent-containing additives. Remove standing moisture immediately.

- Note: To avoid scratches on the floor, carefully lift upholstered furniture. Do NOT push, tilt, or drag.

FR IMPORTANT! À CONSERVER POUR TOUTE CONSULTATION ULTÉRIEURE. À LIRE ATTENTIVEMENT

MISE EN GARDE: Gardez les petites pièces, les sacs d'emballage et les films hors de portée des bébés et des tout-petits en raison du risque d'étouffement et de possible ingestion!

Pour éviter le risque d'étouffement, les couvertures en plastique doivent être retirées avant utilisation. Détruisez les couvertures ou gardez-les hors de portée des enfants. Veuillez suivre strictement les instructions de montage et les conserver pour référence future. Nous ne pouvons accepter aucune responsabilité en cas de montage incorrect. N'utilisez pas l'article si un composant structurel manque ou est endommagé, compromettant sa stabilité. Le non-respect des instructions, les modifications du produit ou l'utilisation de pièces non originales annulent toute garantie ou réclamation de responsabilité. Notre gamme est exclusivement conçue pour un usage privé. Selon les instructions de montage, de nombreux articles nécessitent une fixation murale. Si des chevilles/vis sont incluses, elles ne sont adaptées qu'à la maçonnerie solide. Informez-vous sur le matériau de montage approprié pour votre mur avant de procéder au montage et remplacez-le si nécessaire. Faites attention à l'emplacement des conduites d'eau ou électriques.

Les composants électriques qui ne sont pas connectés au réseau électrique via une prise doivent être installés uniquement par des professionnels formés (par exemple, éclairage dans les salles de bains, connexions de cuisinière dans les cuisines). Un manuel séparé est inclus pour tous les composants électriques. Veuillez le suivre impérativement. Les éclairages LED inclus sont destinés à des fins décoratives et ne conviennent pas pour l'éclairage principal d'une pièce.

Vérifiez régulièrement les connexions des vis et serrez-les si nécessaire. Respectez les spécifications de charge dans les instructions de montage. Si des vis de sécurité supplémentaires sont prévues dans les instructions de montage pour une fixation murale sécurisée, elles doivent être installées (par exemple, étagères murales, grands placards suspendus, etc.).

Les nouveaux meubles dégagent généralement une odeur caractéristique. L'odeur des meubles neufs est causée par la libération de diverses substances volatiles provenant des matériaux utilisés en très petites concentrations. Ces substances ne sont pas régénérées et se dissipent d'elles-mêmes après une aération adéquate en peu de temps. Maintenez une température ambiante moyenne d'environ 18-23 degrés Celsius et un taux d'humidité de 40-55%, et aérez régulièrement pour prévenir la formation de moisissures. Retournez et faites pivoter les matelas régulièrement pour éviter les creux. Nettoyez les meubles avec des chiffons en coton légèrement humides. Évitez les chiffons en microfibre et les agents de nettoyage contenant des additifs abrasifs ou des solvants. Éliminez immédiatement l'humidité stagnante.

- Remarque: Pour éviter les rayures sur le sol, soulevez délicatement les meubles rembourrés. Ne poussez PAS, ne basculez PAS, ne tirez PAS.

PL WAŻNE! ZACHOWAĆ DO PÓŹNIEJSZEGO WGLĄDU. PROSZĘ UWAGAŃIE PRZECZYTAĆ

OSTRZEŻENIE: Trzymaj małe części, worki opakowaniowe i folie z dala od niemowląt i małych dzieci ze względu na ryzyko uduszenia i możliwości połknięcia!

Aby uniknąć ryzyka uduszenia, należy przed użyciem usunąć plastikowe osłony. Osłony należy zniszczyć lub trzymać z dala od dzieci.

Prosimy o ścisłe przestrzeganie instrukcji montażu i zachowanie ich do przyszłego użycia. Nie ponosimy odpowiedzialności za nieprawidłowy montaż. Nie używaj produktu, jeśli brakuje jakiegokolwiek elementu konstrukcyjnego lub jest uszkodzony, co wpływa na jego stabilność. Nieprzestrzeganie instrukcji, wprowadzanie zmian w produkcie lub użycie nieoryginalnych części powoduje utratę gwarancji i wszelkich roszczeń odszkodowawczych. Nasz asortyment jest przeznaczony wyłącznie do użytku prywatnego. Zgodnie z instrukcją montażu wiele produktów wymaga mocowania do ściany. Jeżeli dołączone są kołki/wkręty, są one przeznaczone wyłącznie do mocnego muru. Przed montażem na ścianie sprawdź odpowiedni materiał montażowy do swojej ściany i w razie potrzeby wymień go. Zwróć uwagę na przebieg przewodów wodnych i elektrycznych.

Elementy elektryczne, które nie są podłączone do sieci elektrycznej za pomocą gniazdek, powinny być instalowane wyłącznie przez odpowiednio przeszkolony personel (np. oświetlenie w łazienkach, podłączenia kuchenne w kuchniach). Do wszystkich elementów elektrycznych dołączona jest osobna instrukcja. Prosimy o jej ścisłe przestrzeganie. Dołączone oświetlenie LED służy celom dekoracyjnym i nie nadaje się do głównego oświetlenia pomieszczenia.

Regulamin sprawdź połączenia śrubowe i w razie potrzeby dokręć je. Przestrzegaj obciążeni podanych w instrukcji montażu. Jeżeli w instrukcji montażu przewidziane są dodatkowe śruby zabezpieczające do bezpiecznego mocowania do ściany, muszą one zostać zamontowane (np. półki ściennie, duże szafki wiszące, itp.).

Nowe meble zazwyczaj emitują charakterystyczny zapach. Zapach nowych mebli jest spowodowany uwalnianiem różnych lotnych substancji z użytych materiałów w bardzo małych stężeniach. Substancje te nie są regenerowane i znikają same po odpowiednim przewietrzeniu w krótkim czasie. Utrzymaj średnią temperaturę w pomieszczeniu na poziomie około 18-23 stopni Celsjusza oraz wilgotność powietrza między 40-55%.

Regularnie wietrz pomieszczenie, aby zapobiec powstawaniu pleśni. Regulamin obracaj i odwracaj materace, aby zapobiec tworzeniu się wgnębień. Czyść meble lekko wilgotnymi ściereczkami. Unikaj ściereczek z mikrofibry i środków czyszczących z wierających dodatków ściernych lub rozpuszczalnik. Natychmiast usuwaj stojącą wilgoć.

- Uwaga: Aby uniknąć zarysowań na podłodze, ostrożnie podnoś meble tapicerowane. NIE przesuwaj, NIE przychylaj, NIE dajgnij.

IT IMPORTANTE! CONSERVARE PER CONSULTAZIONE FUTURA. LEGGERE CON ATTENZIONE

ATTENZIONE: Tenere piccole parti, sacchetti di imballaggio e pellicole lontano da neonati e bambini piccoli a causa del rischio di soffocamento e possibile ingestione!

Per evitare il rischio di soffocamento, rimuovere le coperture di plastica prima dell'uso. Distruggi o tieni le coperture lontano dai bambini.

Si prega di seguire attentamente le istruzioni di montaggio e conservarle per future referenze. Non possiamo accettare alcuna responsabilità per il montaggio errato. Non utilizzare l'articolo se è danneggiato, compromettendone la stabilità. Il mancato rispetto, le modifiche al prodotto o l'uso di parti non originali annulleranno qualsiasi garanzia o richiesta di risarcimento. La nostra gamma è progettata esclusivamente per uso privato. Secondo le istruzioni di montaggio, molti articoli richiedono il fissaggio a parete. Se sono inclusi tasselli/viti, questi sono adatti solo per muratura solida.

Informarsi sul materiale di montaggio adatto per la propria parete prima del montaggio e sostituirlo se necessario. Prestare attenzione al percorso delle tubature nell'acqua o dei cavi elettrici. I componenti elettrici che non sono collegati alla rete elettrica tramite una presa devono essere installati solo da personale qualificato (ad esempio, illuminazione nei bagni, collegamenti delle cucine). Per tutti i componenti elettrici è inclusa una guida separata. Si prega di seguirli attentamente. Le illuminazioni a LED incluse sono destinate a scopi decorativi e non sono adatte all'illuminazione principale di una stanza.

Controllare regolarmente le connessioni delle viti e serrarle se necessario. Osservare le specifiche di carico nelle istruzioni di montaggio. Se nelle istruzioni di montaggio sono previste viti di sicurezza aggiuntive per un fissaggio sicuro alla parete, queste devono essere installate (ad esempio, mensole a muro, grandi armadi sospesi, ecc.).

I mobili nuovi generalmente emettono un odore caratteristico. L'odore dei mobili nuovi è causato dal rilascio di varie sostanze volatili dai materiali utilizzati in concentrazioni molto basse. Queste sostanze non vengono rigenerate e si dissipano da sole dopo un'adeguata ventilazione in breve tempo. Mantenere una temperatura ambiente media di circa 18-23 gradi Celsius e un'umidità dell'aria tra il 40-55%, e ventilare regolarmente per prevenire la formazione di muffa. Girare e ruotare regolarmente i materassi per evitare la formazione di avallamenti. Pulire i mobili con panni di cotone leggermente umidi. Evitare panni in microfibra e detersivi contenenti additivi abrasivi o solvanti. Rimuovere immediatamente l'umidità stagnante.

- Nota: Per evitare graffi sul pavimento, sollevare con cautela i mobili imbottiti. NON spingere, inclinare o trascinare.

