

REPC-Nr.:

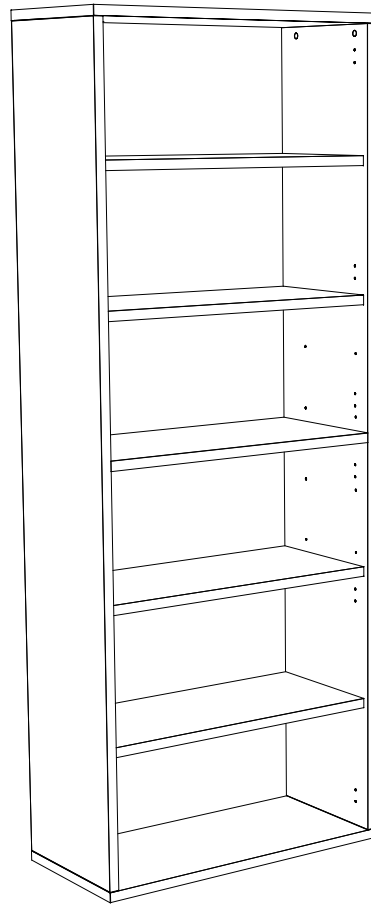

Artikel.-Nr.:

Montageanleitung.-Nr.:

**2000-R-82x218**



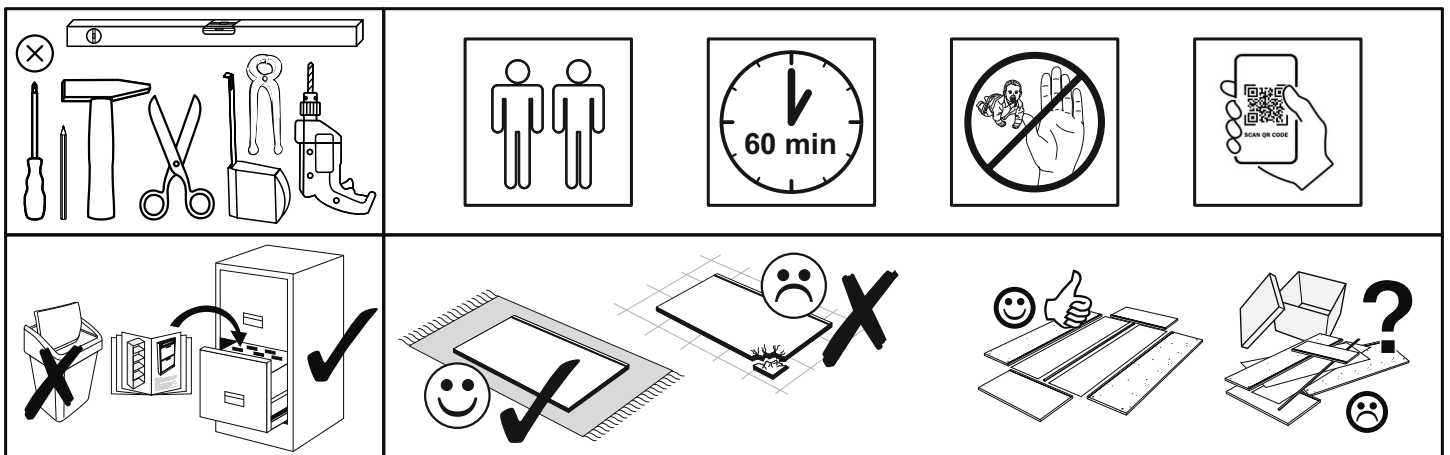



**MA1-00567**

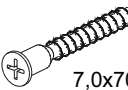

SCAN ME

Das Ersatzteil-Anforderungsformular finden Sie auf  
The replacement parts requisition form you find on  
<https://www.mausbacher.de/ersatzteile/>

## BT1-00666 Colli 1/2

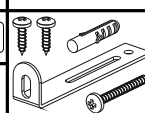
B01-20		B01-30		B01-90		B05-185	
4x	7,0x70	35x	3x16	6x	3,5x20	6x	
B02-10		B02-20		B05-20		B08-80	
24x	ø15x12mm	24x		4x		1x	

## BT1-00005 Colli 1/2

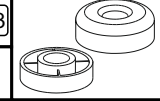
B01-123		B02-173	
8x	4,0x15	4x	

## Colli 1/2

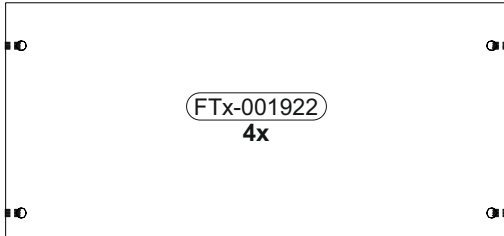

768x359

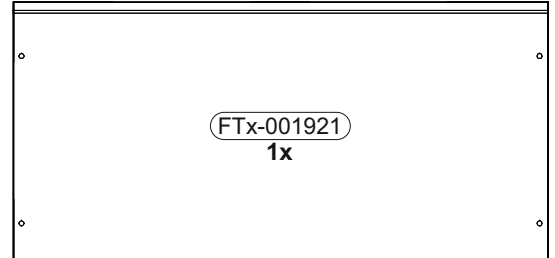

819x395

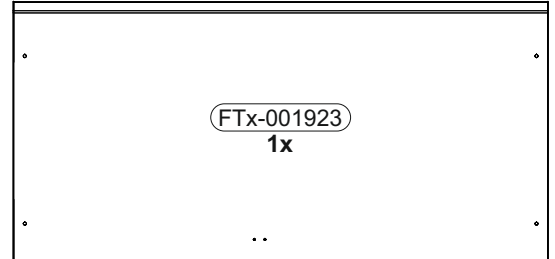

819x395

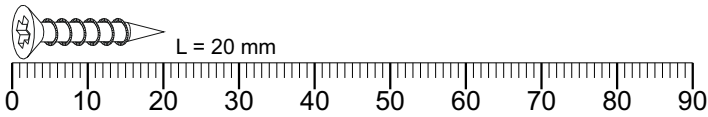

## Colli 2/2

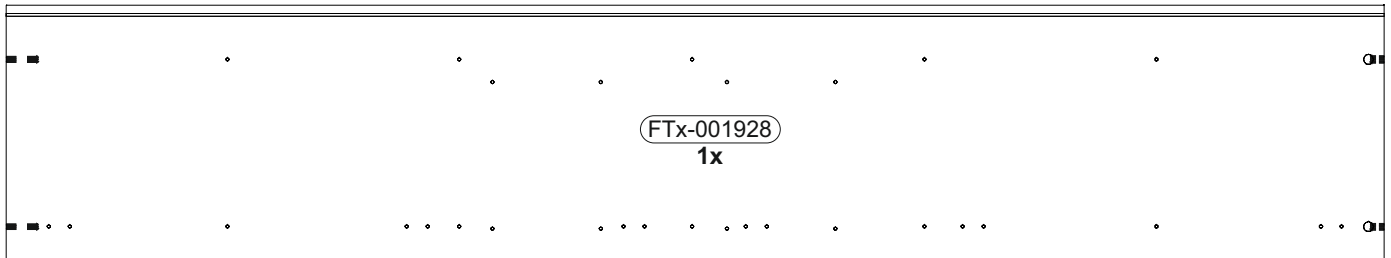

2109x394

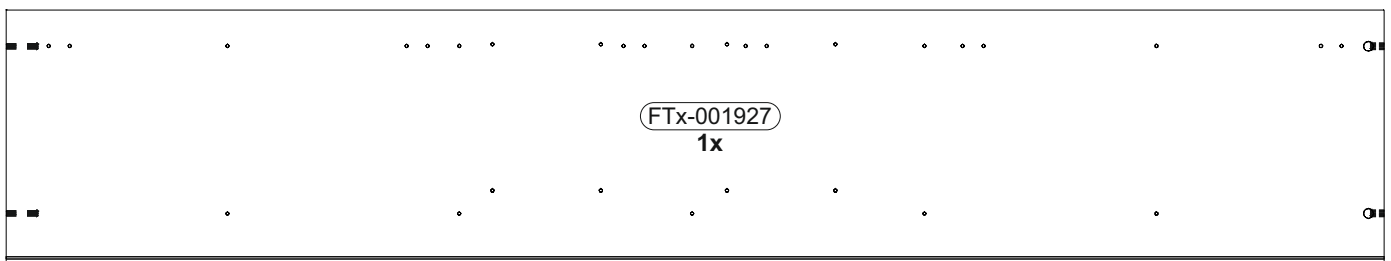

2109x394

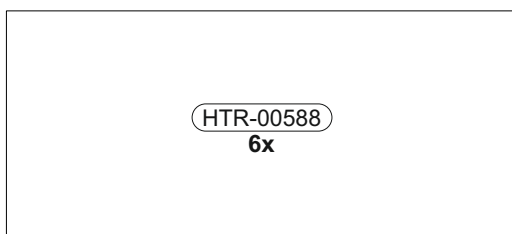

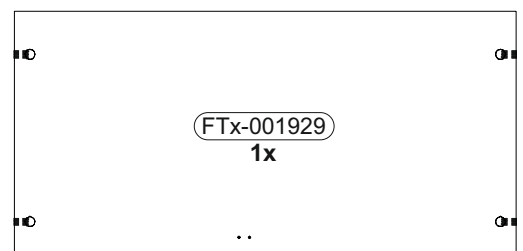

353x780





768x377

**1**

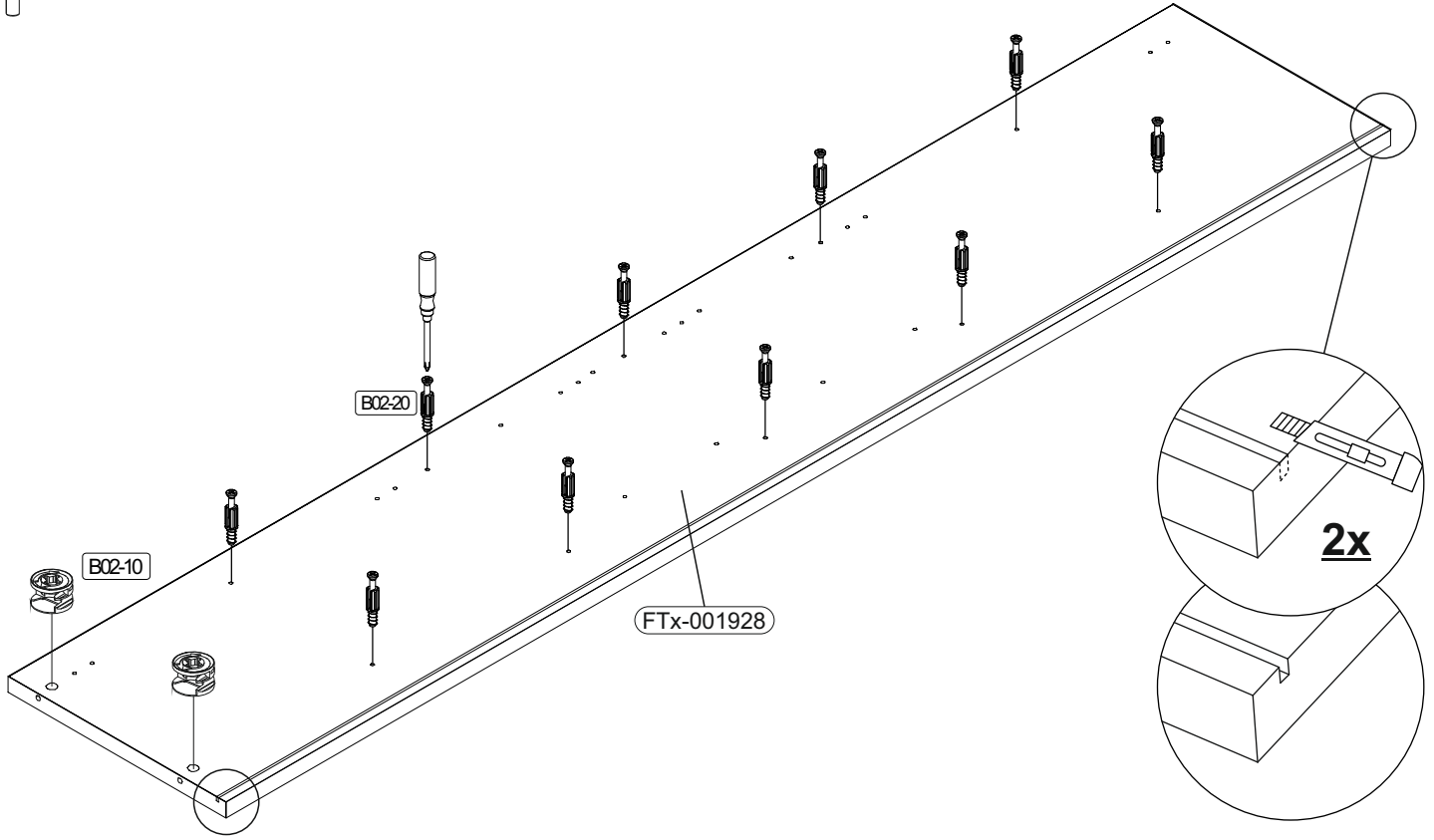
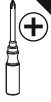
B02-10		B02-20	
2x	ø15x12mm	10x	



**2**

B02-10		B02-20	
2x	ø15x12mm	10x	

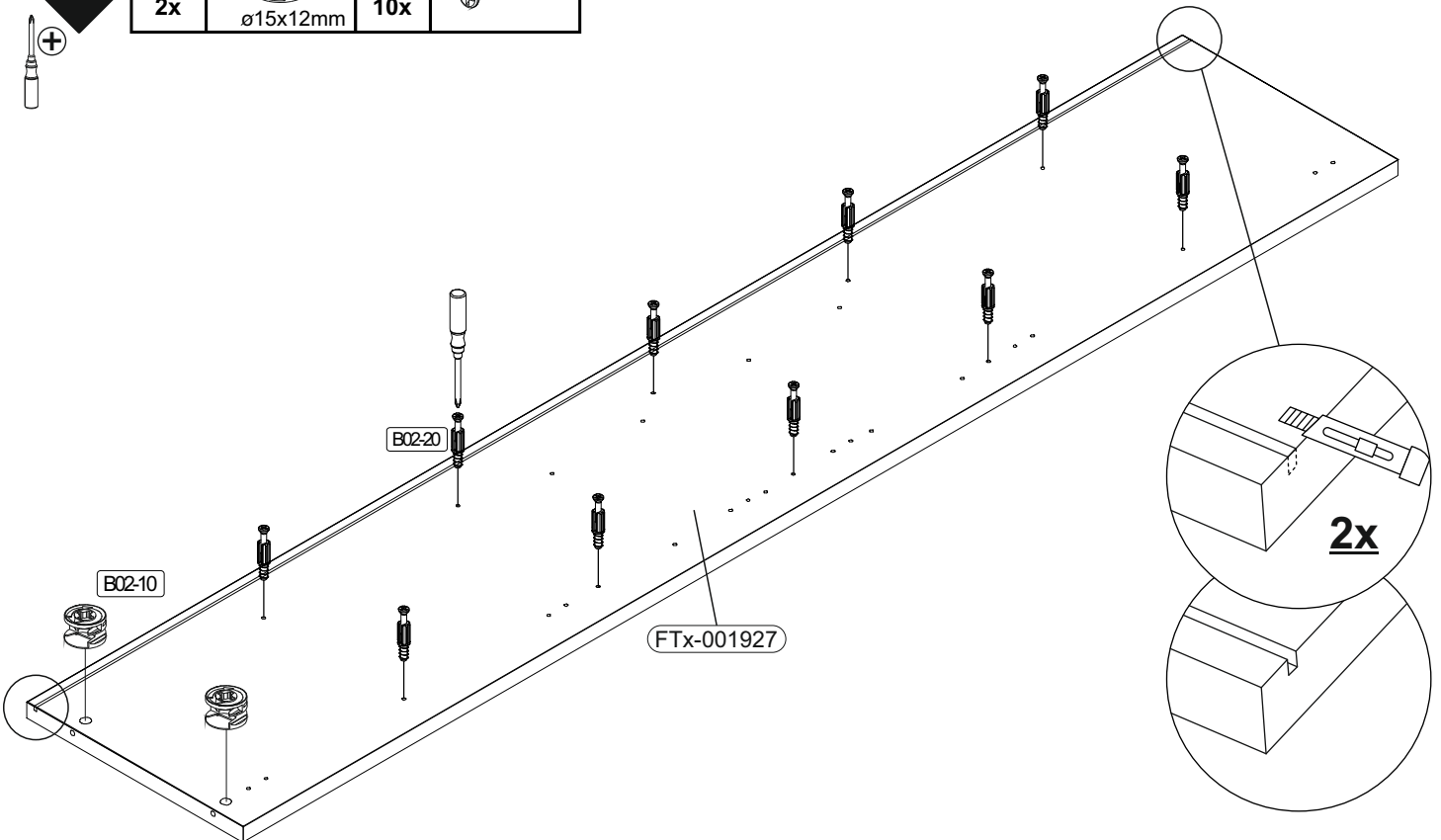
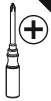



6

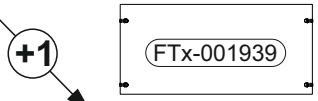
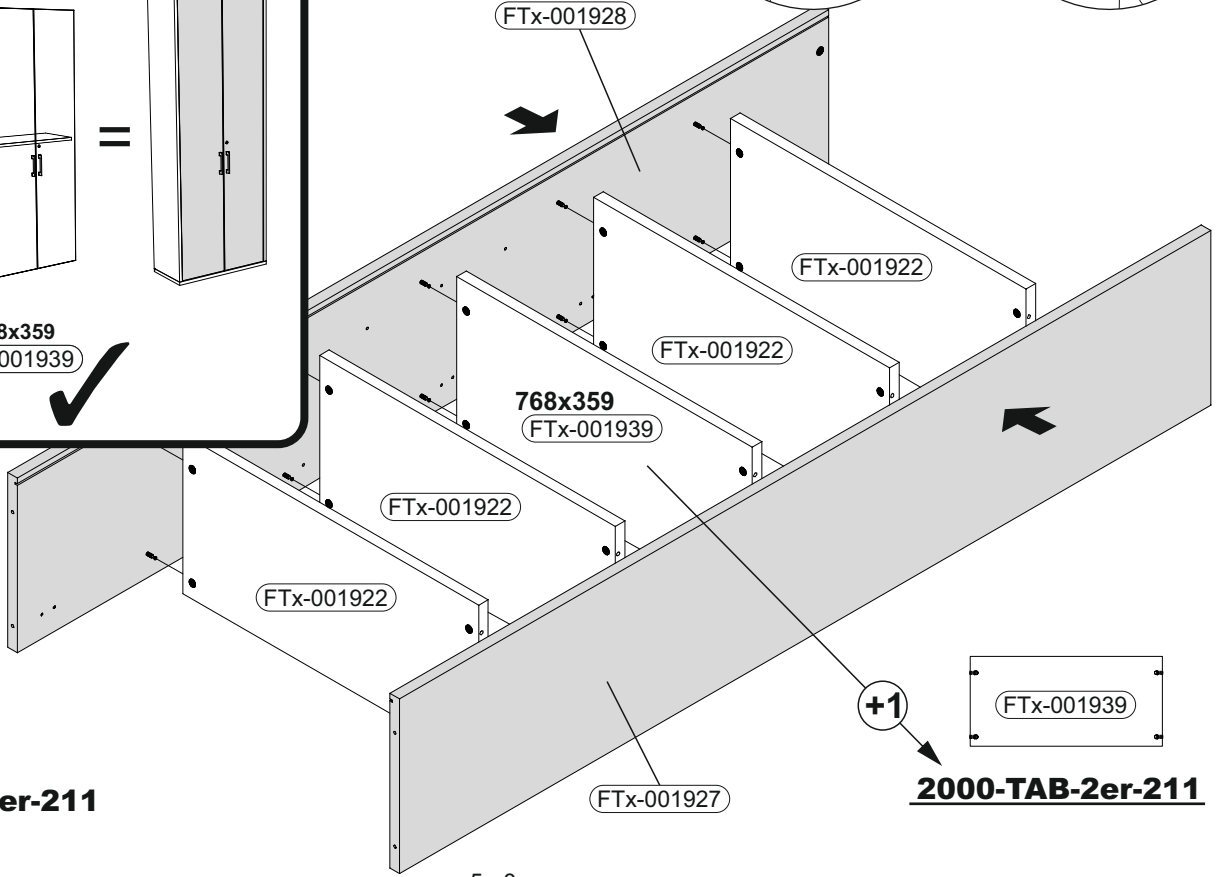
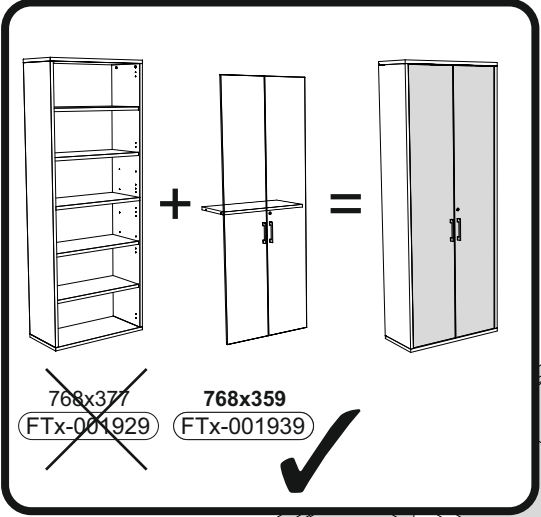
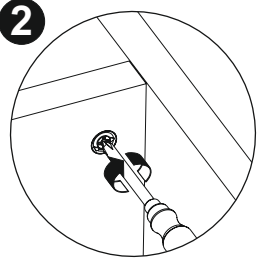
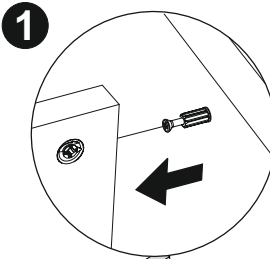
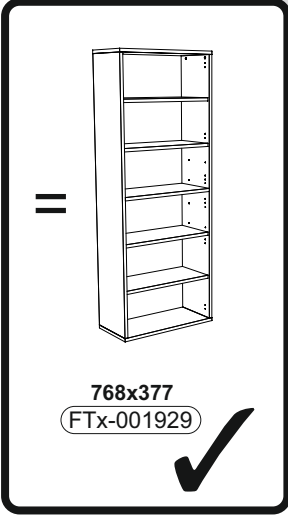
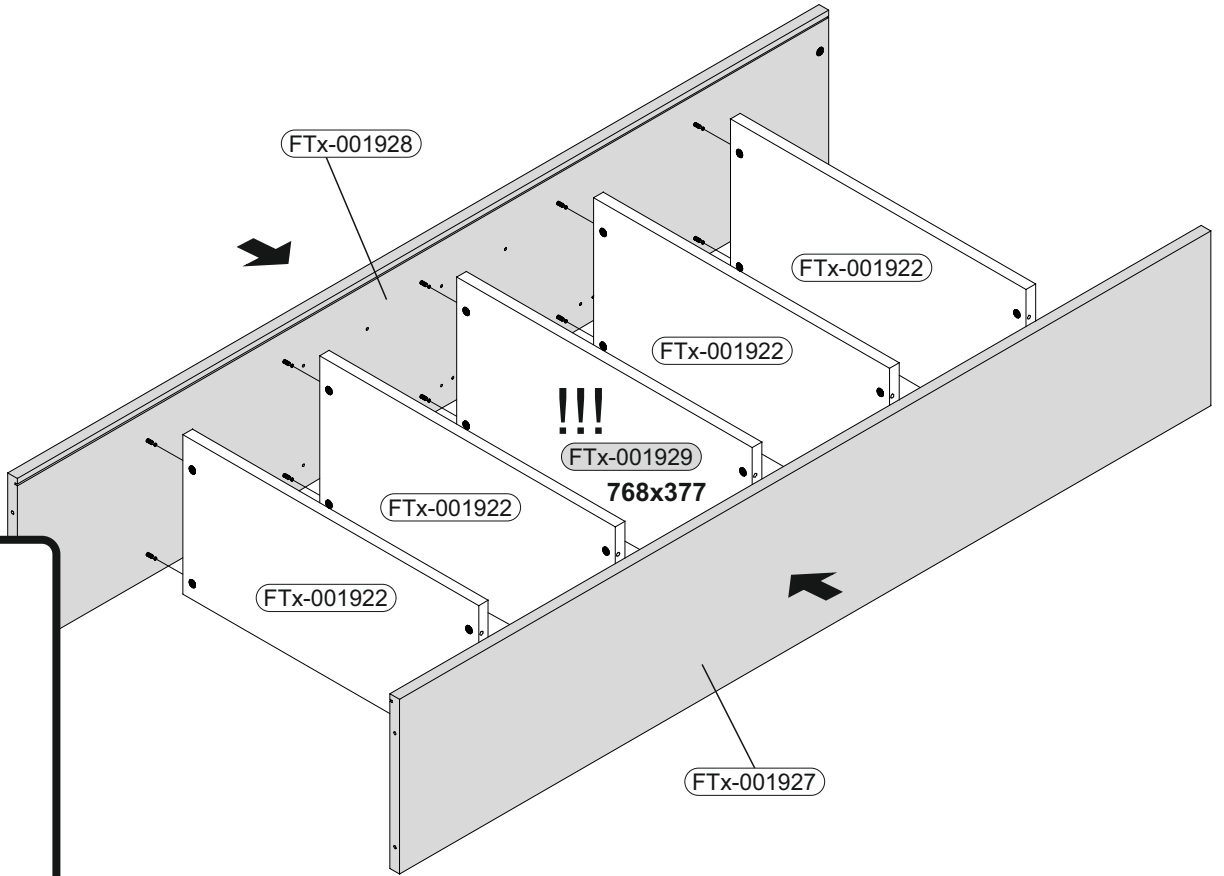
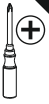

**2000-TAB-2er-211**

**MA1-00574**  
**2000-TAB-2er-211**

7

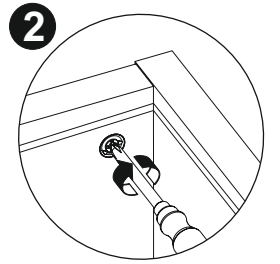
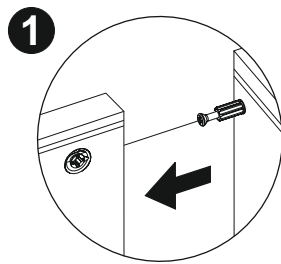
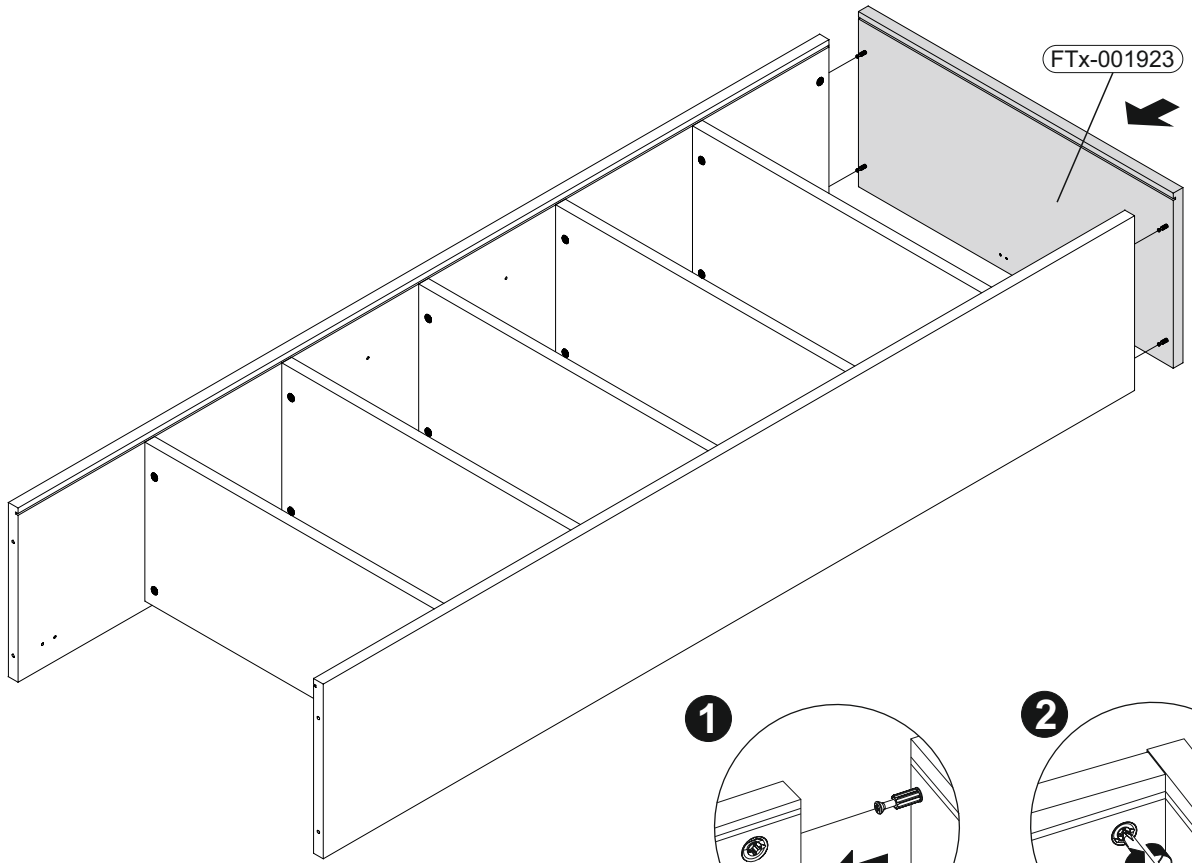
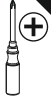

8

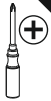

B01-20  
4x  
7,0x70

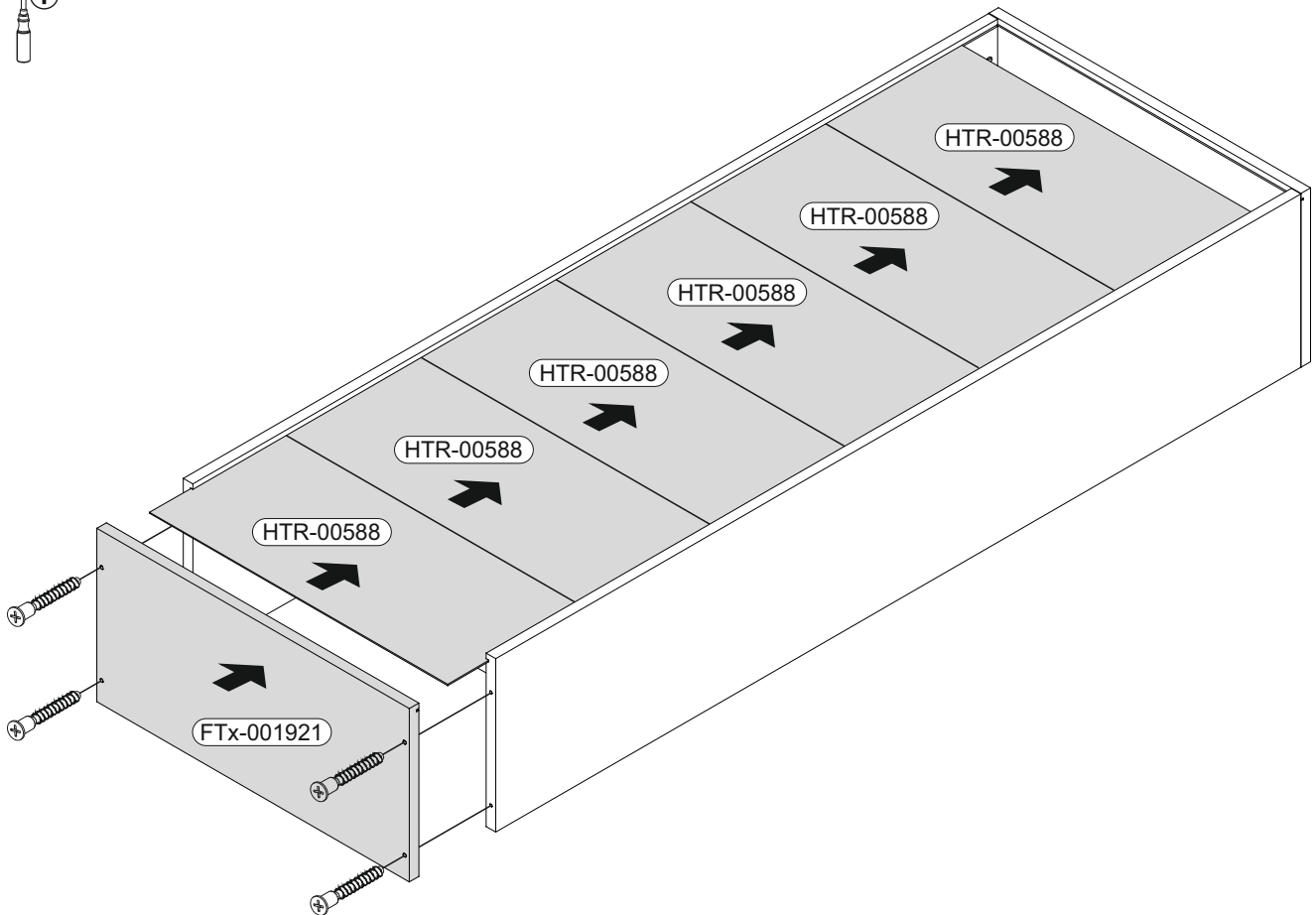

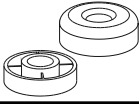

9

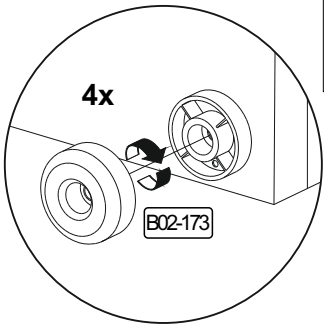
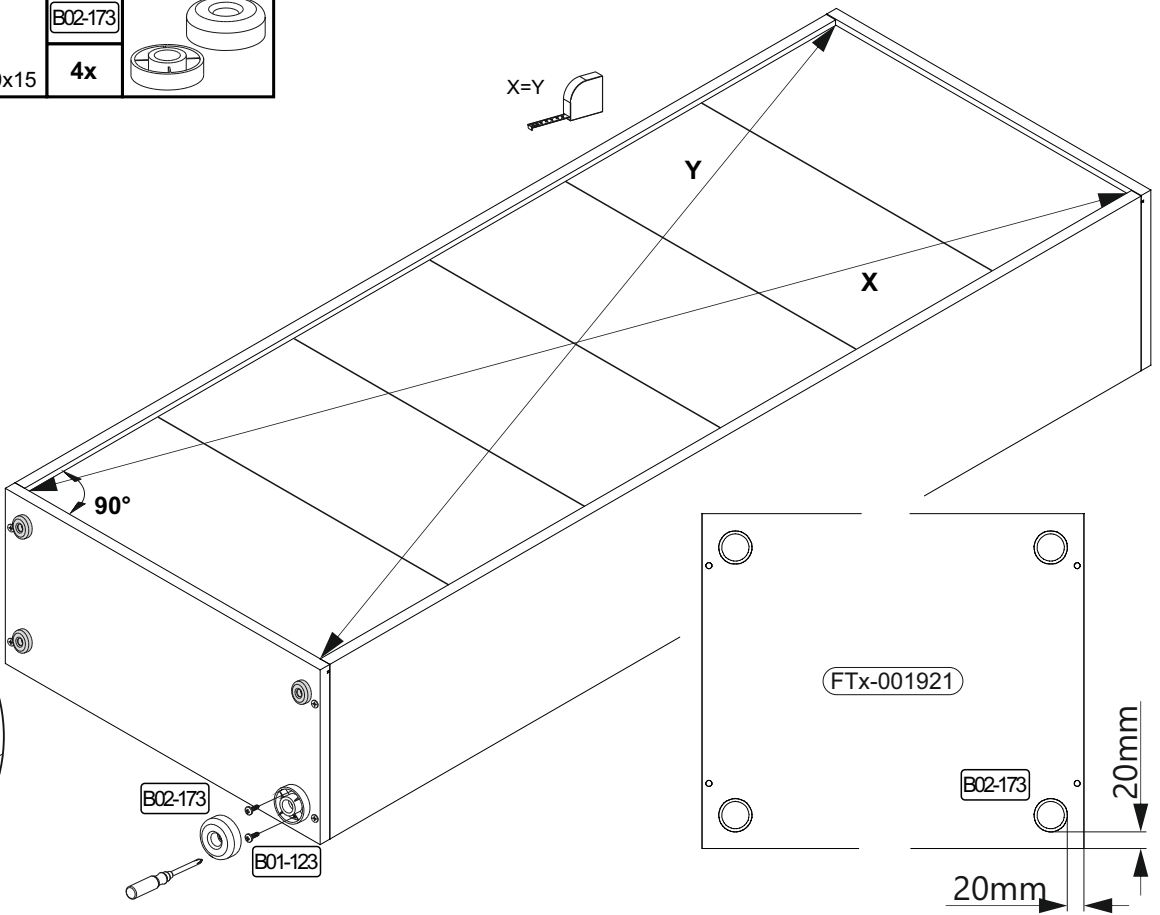
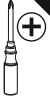
B01-123		B02-173	
8x	4,0x15	4x	



10

B01-30		
35x	3x16	
B01-90		
6x	3,5x20	
B05-185		
6x		

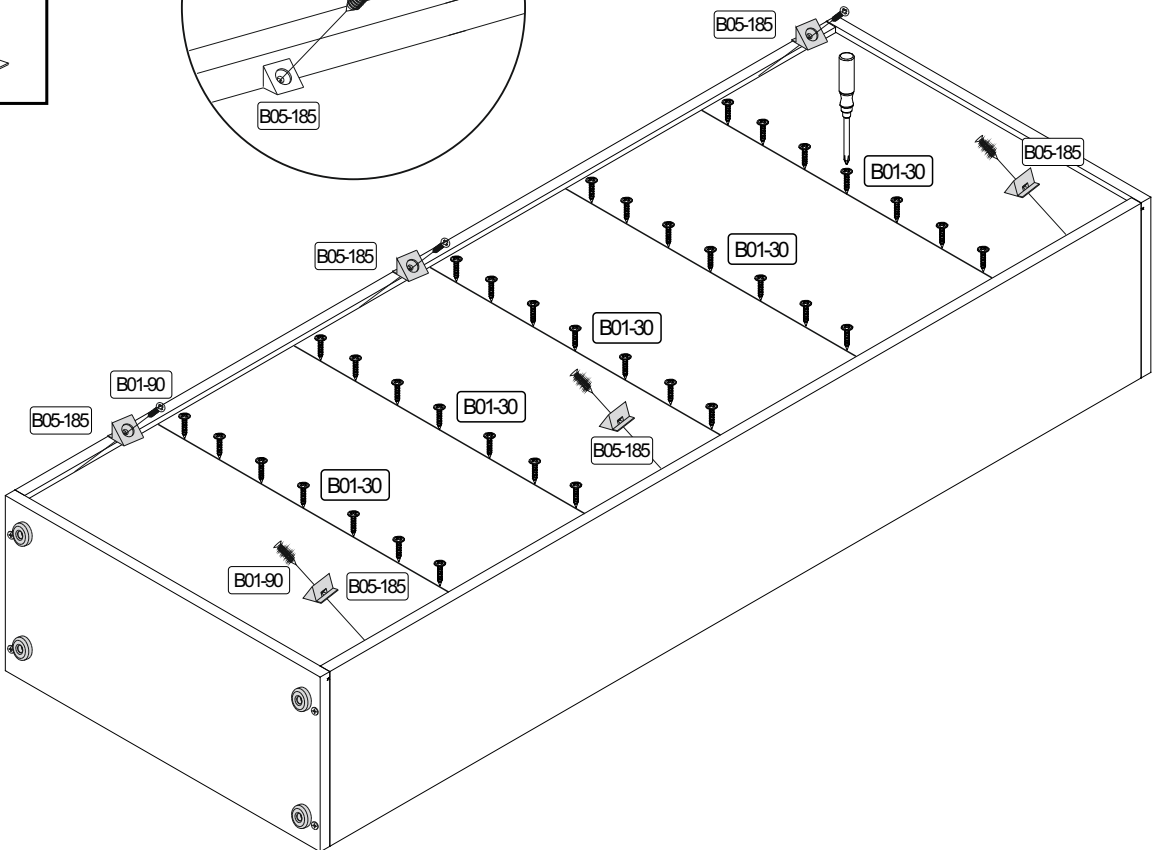
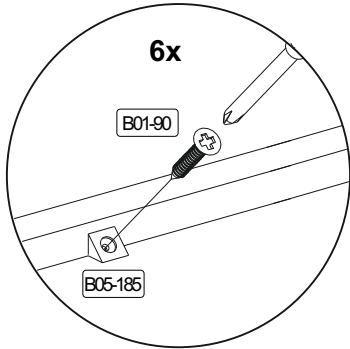



B08-80		B05-20	
1x		4x	

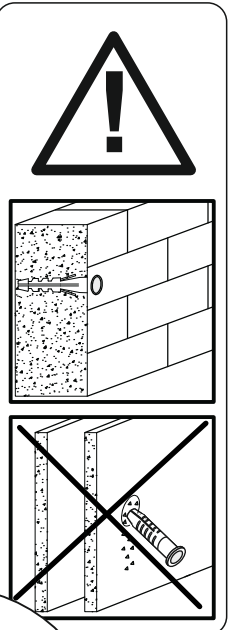
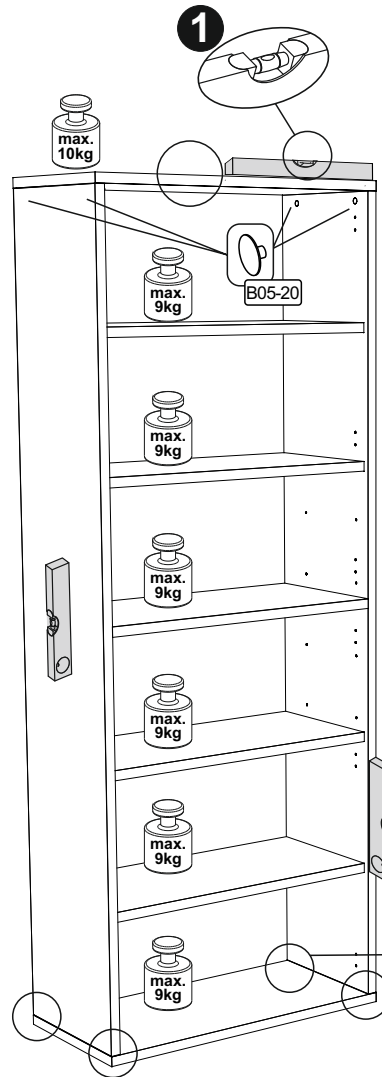
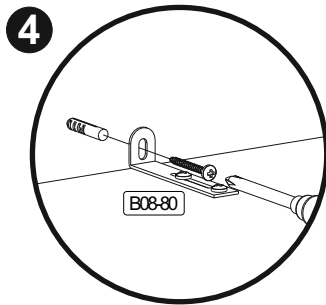
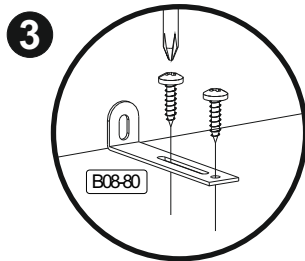

<b>Achtung • Attention • Attenzione • Opgelet • Uwaga • Pozor • Figelem • Atenție • Dikkat • Внимание • Fara • Vaara • Fare • Peligro</b>	
<b>(D)</b>	Wandbefestigung dient als Kippschutz - unbedingt anbringen! Bei einigen Wandtypen kann ein Spezialdübel erforderlich sein!
<b>(GB)</b>	The wall fastening serves to prevent tipping - be absolutely sure to mount it! For certain wall types, a special wall plug may be necessary!
<b>(FR)</b>	La fixation murale sert de protection contre le basculement – à installer impérativement ! Pour certains types de murs il faut des chevilles spéciales !
<b>(TR)</b>	Duvardaki sabitleme, devrilmeye karşı bir emniyet tedbidir ve mutlaka monte edilmelidir! Bazı duvar tiplerinde bunun için özel bir dübel gerekli olabilir!
<b>(IT)</b>	Il fissaggio alla parete serve da protezione anti-ribaltamento – attaccarla assolutamente! Per alcune strutture di parete può essere necessario un tassello speciale!
<b>(NL)</b>	Bevestiging aan de muur dient als kantelbescherming – zeker en vast bevestigen! Bij enkele muurtypes is een speciale plug misschien vereist!
<b>(RU)</b>	Обязательно установите крепление на стене во избежание опрокидывания! Для некоторых типов стен может потребоваться специальный дюбель!
<b>(CZ)</b>	Montáž na stěnu slouží jako ochrana proti převrnutí – bezpodmínečně umístěte! U některých typů stěn může být zapotřebí speciální hmoždinka!
<b>(HU)</b>	A terméket a falhoz kel rögzíteni, különben az felborulhat! Egyes faltípusoknál speciális tiplit kell használni!
<b>(RO)</b>	Sistemul de fixare la perete servește ca protecție la răsturnare - de montat obligatoriu! Pentru unele tipuri de pereti este posibil să fie necesar un diblu special!
<b>(PL)</b>	Mocowanie do ściany jest jednocześnie zabezpieczeniem przed przewróceniem – koniecznie zamontować! Do niektórych rodzajów ścian konieczne zastosować specjalne kołki mocujące.
<b>(SWE)</b>	Väggmontering fungerar som anti-lutningsskydd - det är viktigt att fästa det! En speciell plugg kan behövas för vissa väggtyper!
<b>(FIN)</b>	Seinäkiinnitys toimii kaatumista estävänä suojana - se on ehdottomasti kiinnitettävä! Joihinkin seinätyyppeihin voidaan tarvita erityistappi!
<b>(NOR)</b>	Veggmontering fungerer som anti-vippebeskyttelse - det er viktig å feste det! En spesiell dyvel kan være nødvendig for noen veggtyper!
<b>(DAN)</b>	Vægmontering fungerer som anti-vip beskyttelse - det er vigtigt at fastgøre det! En speciel dyvel kan være påkrævet til nogle vægtyper!
<b>(SK)</b>	Upevnenie na stenu slúži ako ochrana proti prevráteniu – bezpodmienečne použite! Pre niektoré druhy stien môže byť potrebná špeciálna hmoždinka!
<b>(ES)</b>	El montaje en la pared sirve como protección antivuelco: ¡es imprescindible fijarlo! ¡Es posible que se requiera una espiga especial para algunos tipos de paredes!

REPC-Nr.:



Artikel.-Nr.:

Montageanleitung.-Nr.:

**2000-RGL-2er-104**

**MA1-00576**

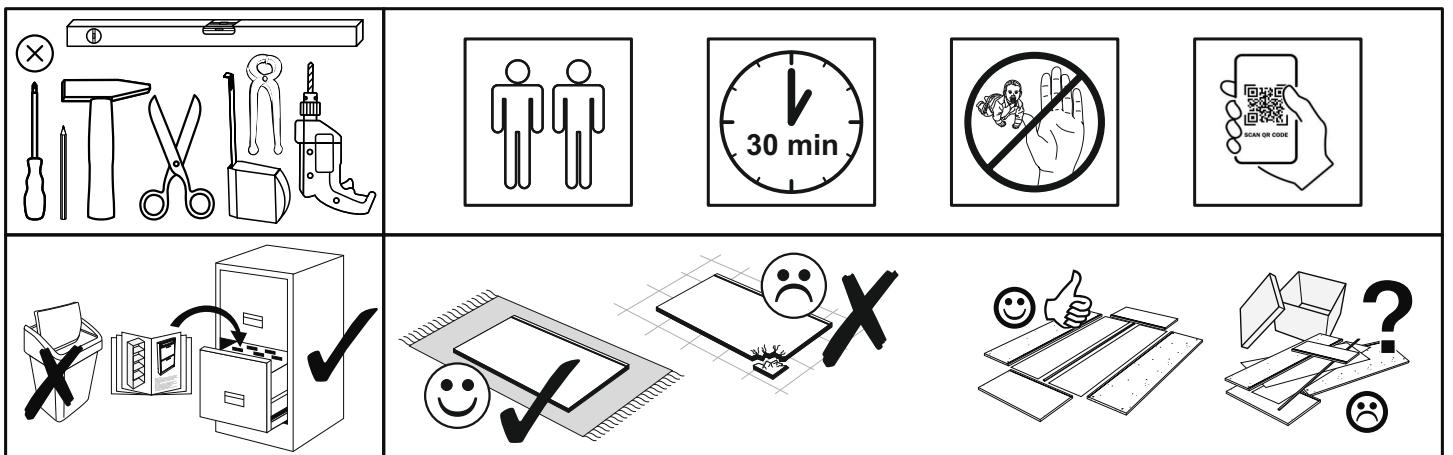

SCAN ME

Das Ersatzteil-Anforderungsformular finden Sie auf  
The replacement parts requisition form you find on  
<https://www.mausbacher.de/ersatzteile/>

## BT1-00230 Colli 1/1

B03-43		B03-11		B03-07	
4x		4x		2x	

## BT1-00672 Colli 1/1

B06-415	
2x	

## BT1-00679 Colli 1/1

B01-329		B01-80		B02-10		B02-103		B02-65		B05-20	
4x	M4x22	8x	3,5x13	16x	ø15x12mm	8x	8x30	8x		16x	

## Colli 1/1

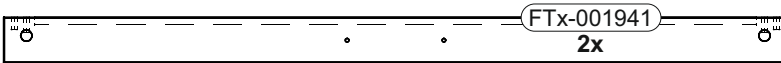

1036x60

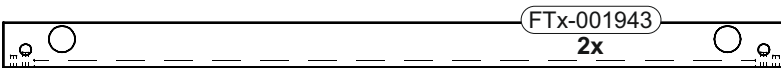

1036x60

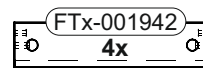

260x60

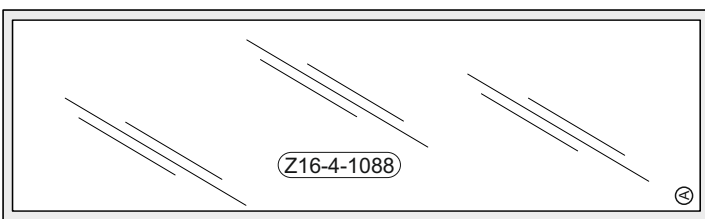

935x279

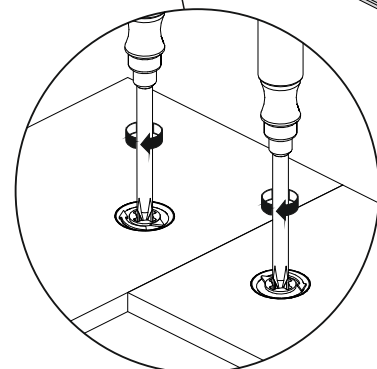
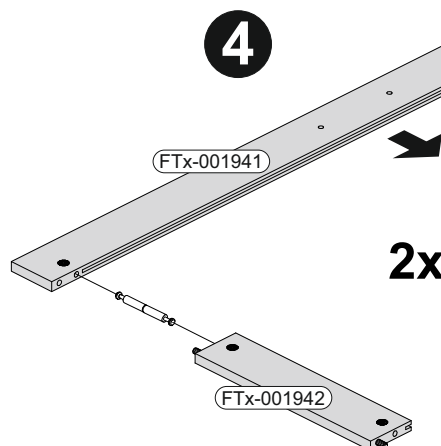
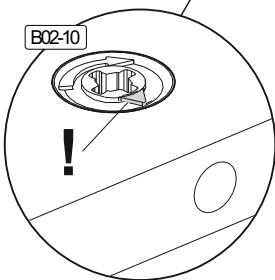
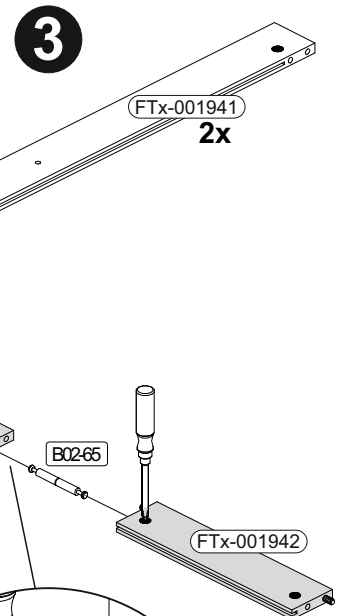
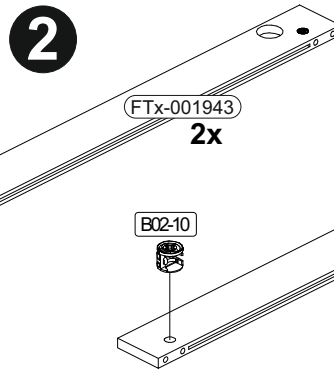
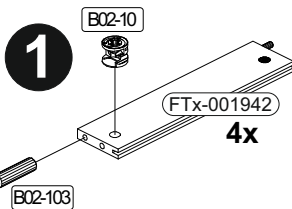
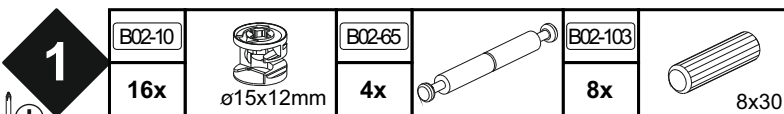

**2**

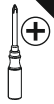

B02-65		B03-43		B01-80		B01-329		B06-415	
4x		4x		8x	3,5x13	4x	M4x22	2x	
B05-20									
16x									

**1**

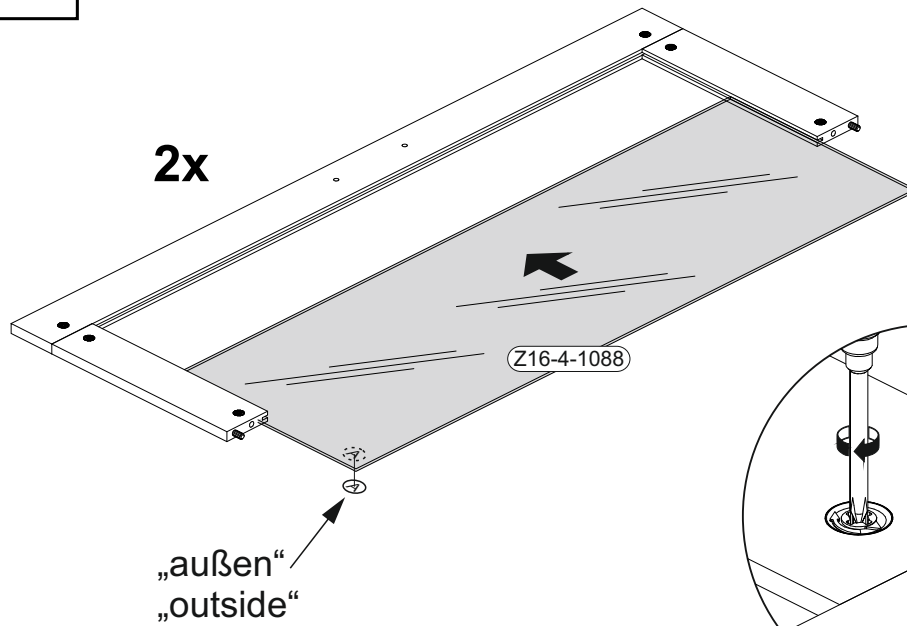

**2**

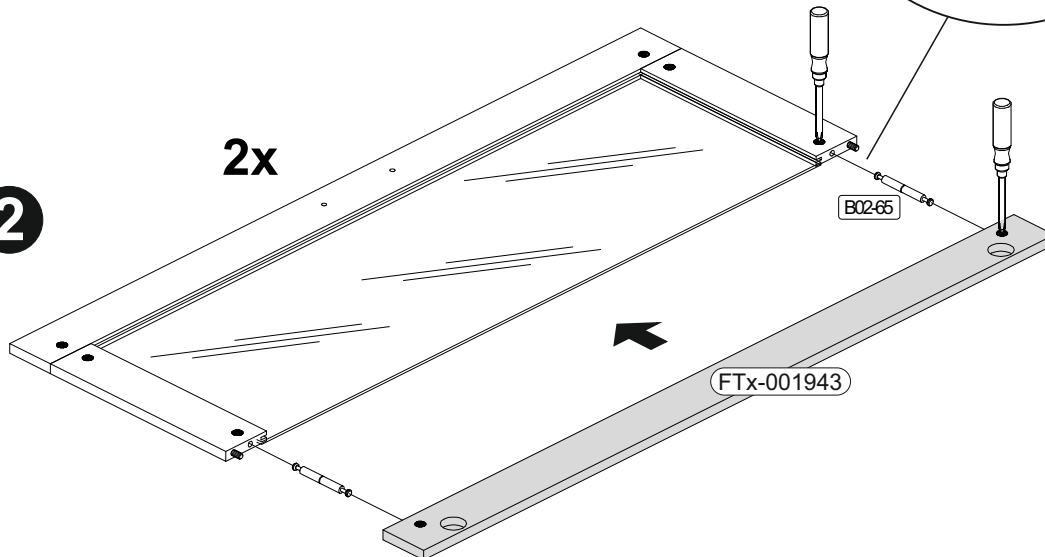

**3**

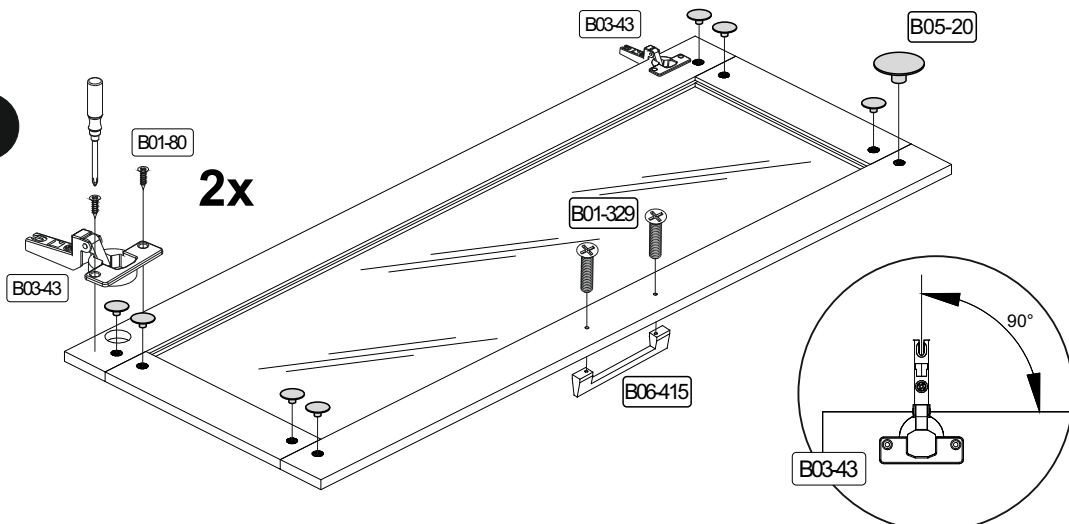

**3**

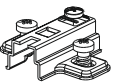
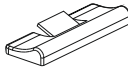
B03-11		B03-07	
4x		2x	

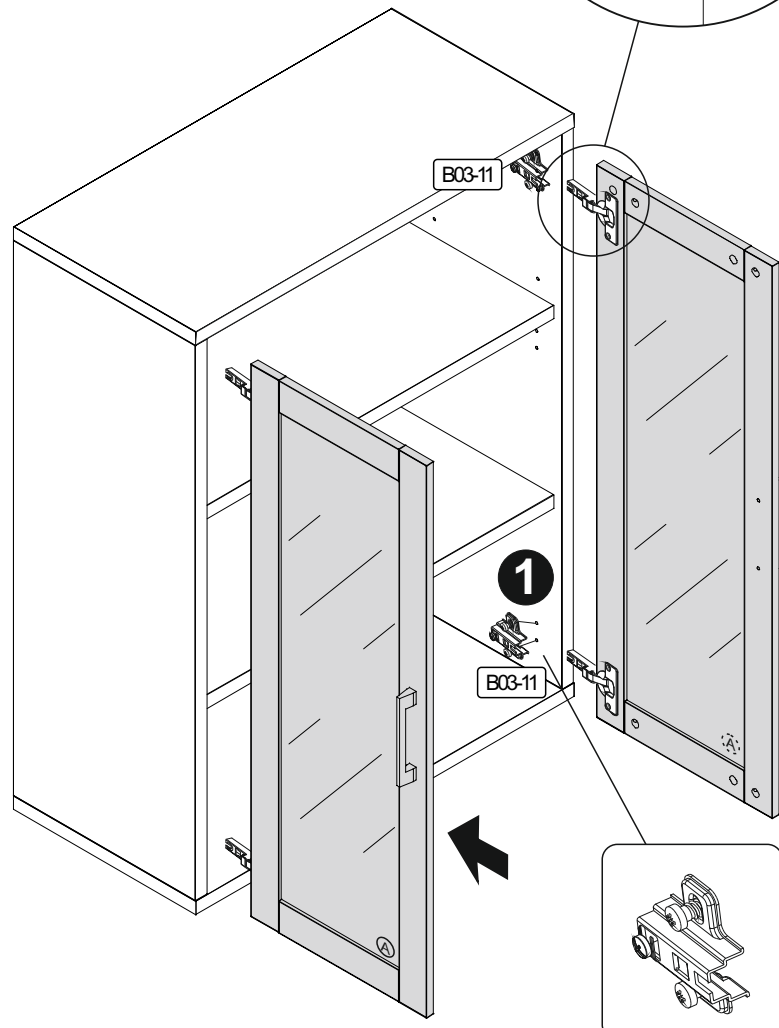
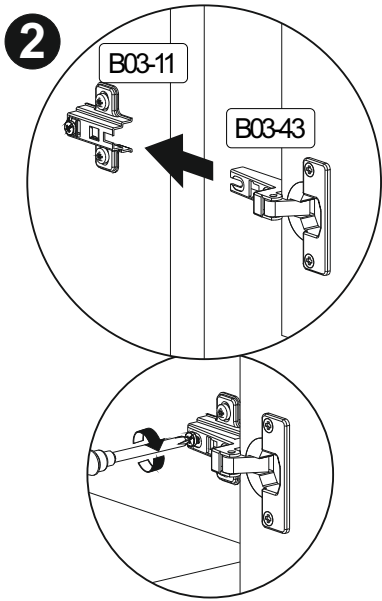
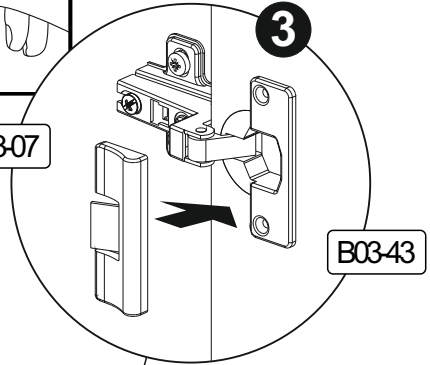
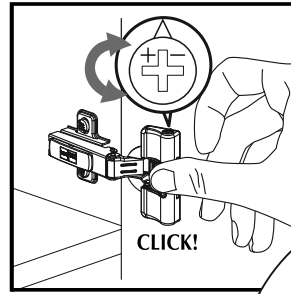
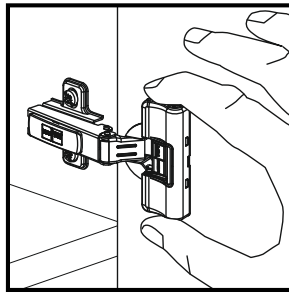
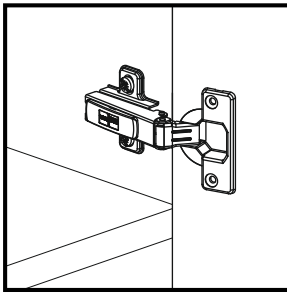
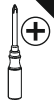

▶ SCAN ME

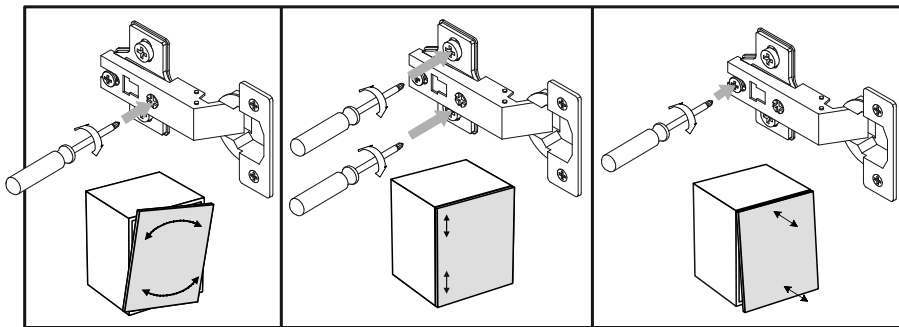

REPC-Nr.:

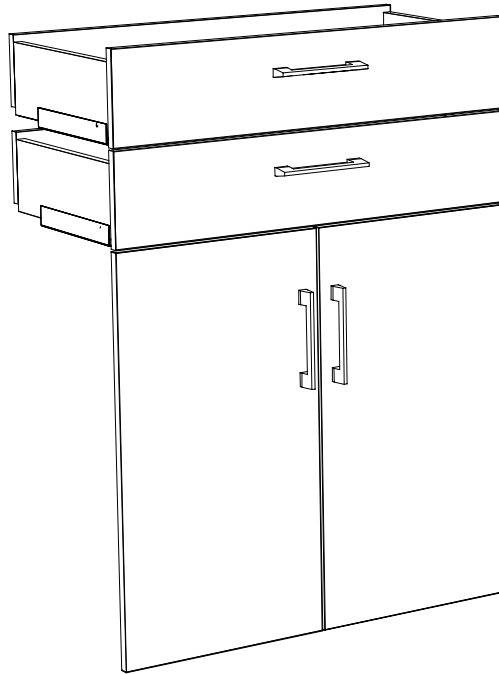

Artikel.-Nr.:

**2000-TS-77-Set**

Montageanleitung.-Nr.:

**MA1-00570**

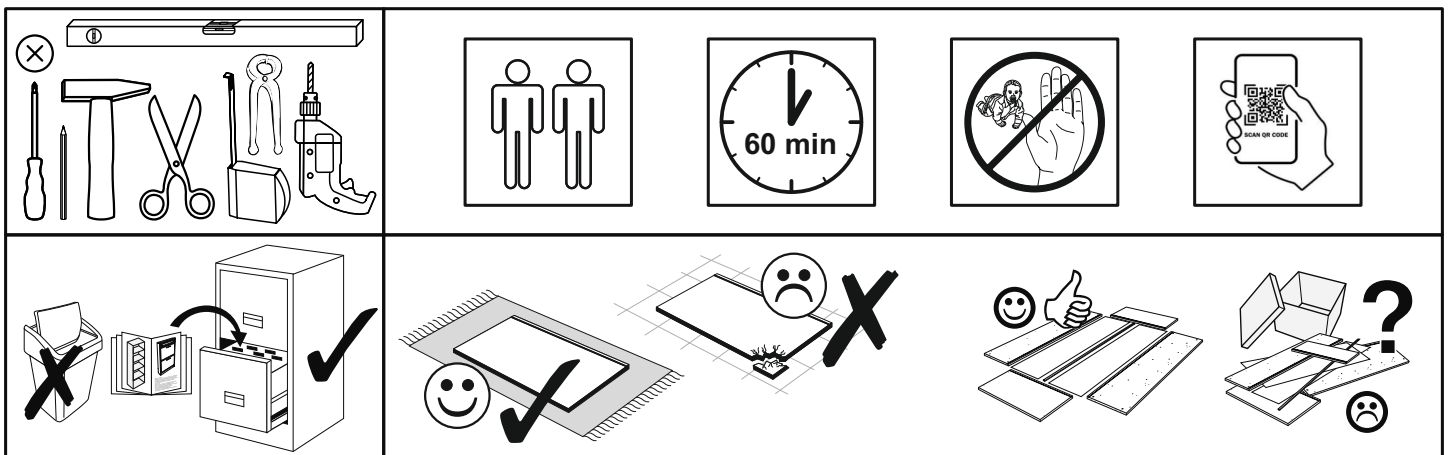

SCAN ME

Das Ersatzteil-Anforderungsformular finden Sie auf  
The replacement parts requisition form you find on  
<https://www.mausbacher.de/ersatzteile/>



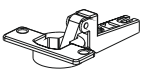
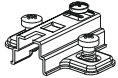
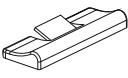



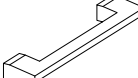



## BT1-00230 Colli 1/1

B03-43		B03-11		B03-07	
4x		4x		2x	

## BT1-00670 Colli 1/1

B06-415	
4x	

## BT1-00669 Colli 1/1

B01-200		B01-30		B01-329		B01-37		B01-80	
8x	6,3x13	16x	3x16	8x	M4x22	1x	4,5x25	8x	3,5x13
B02-10		B02-20		B02-103		B05-20		B01-122	
8x	ø15x12mm	8x		16x	8x30	8x		4x	4x13

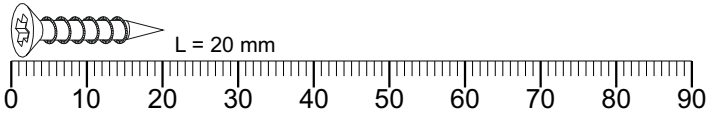

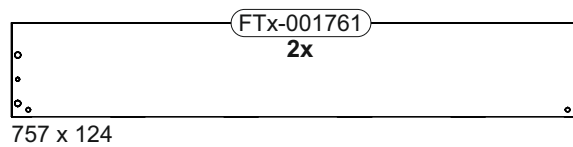
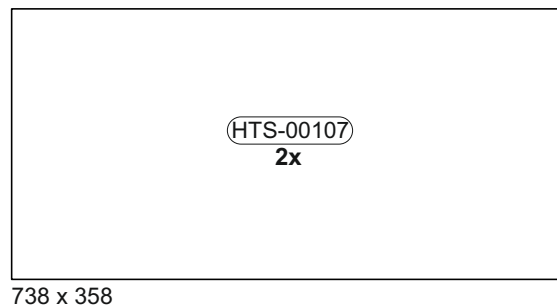
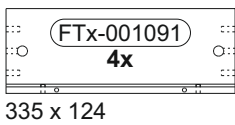
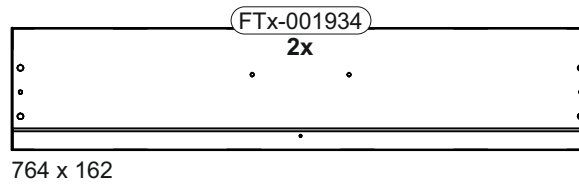
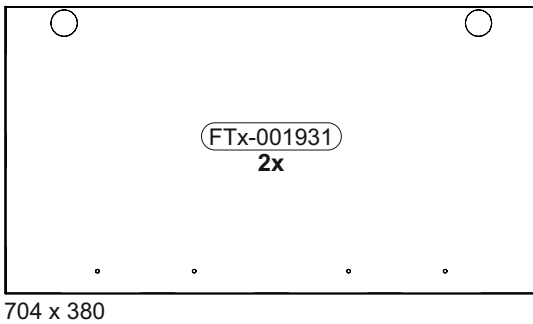
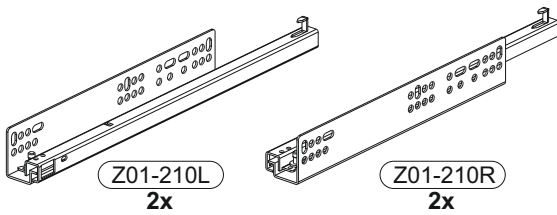

## Colli 1/1

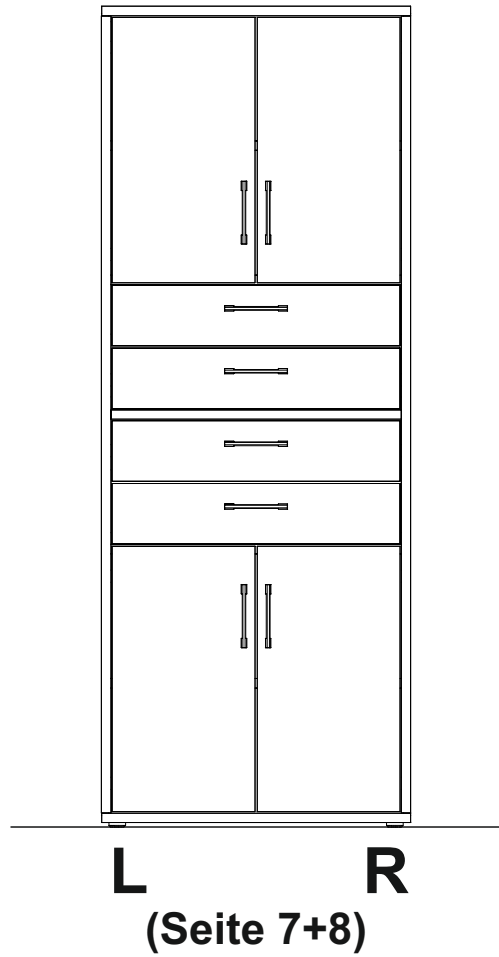
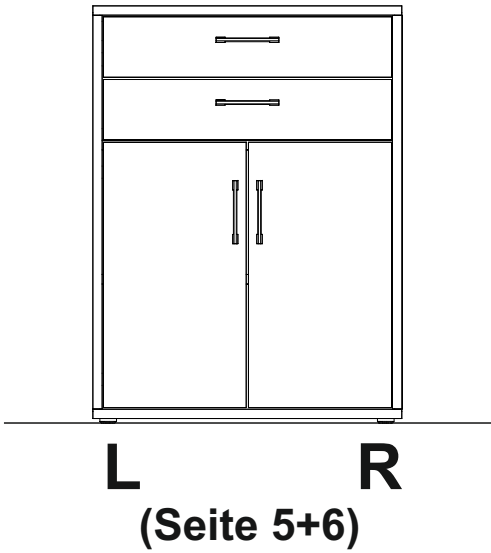



**1**



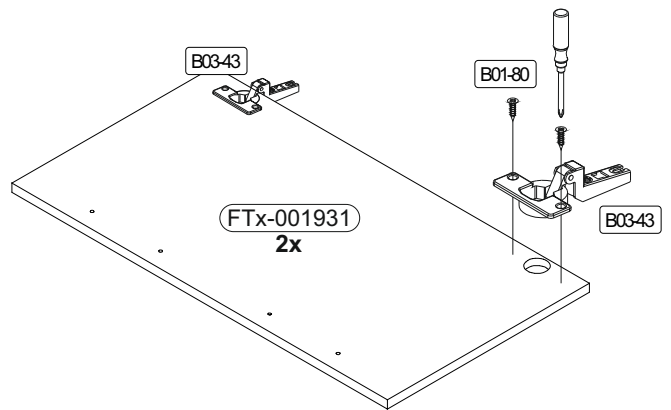
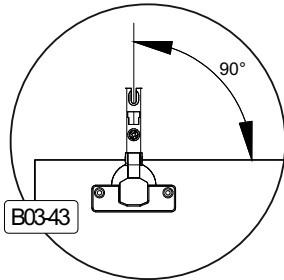

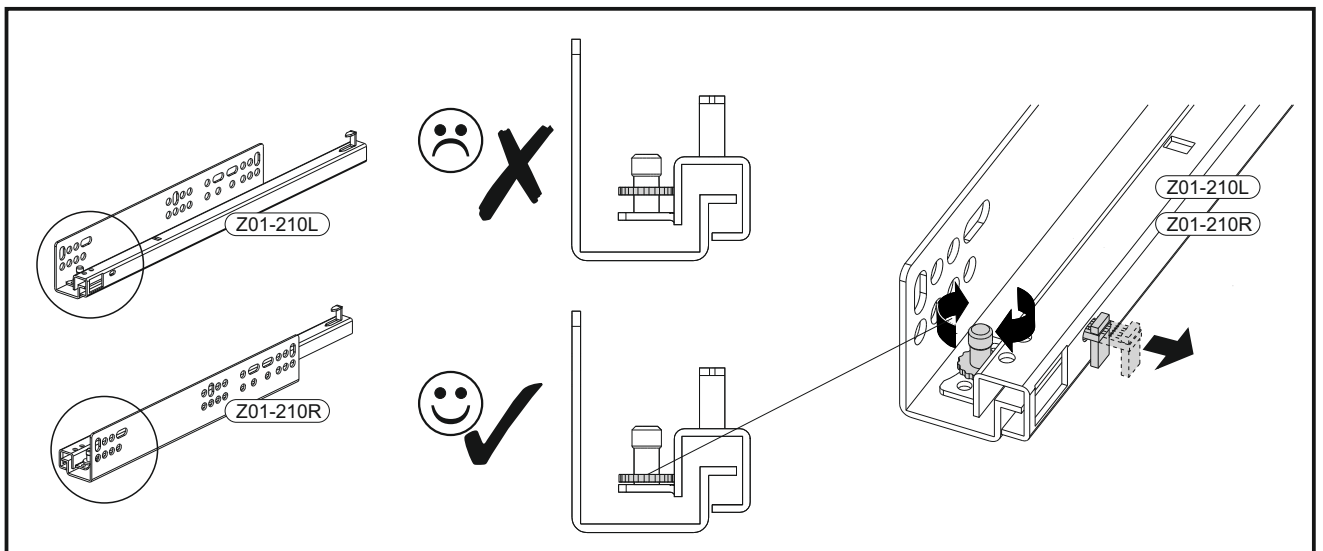

B01-80		B03-43	
8x	3,5x13	4x	



**2**

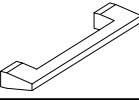

**3**

B02-10 8x	 ø15x12mm	B02-20 8x		B02-103 16x	 8x30	B05-20 8x		B01-122 4x	 4x13
B01-30 16x	 3x16	B01-329 4x	 M4x22	B06-415 2x					

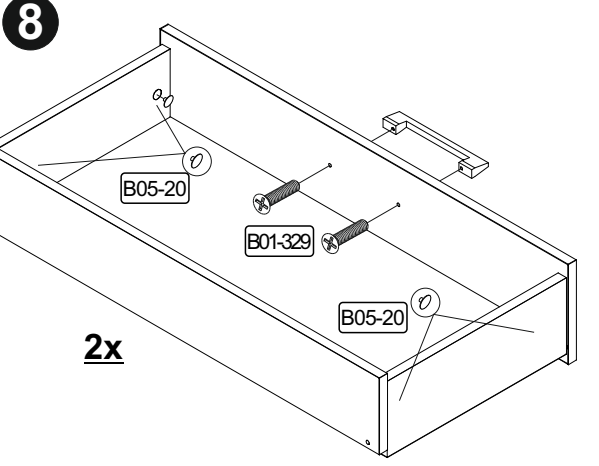
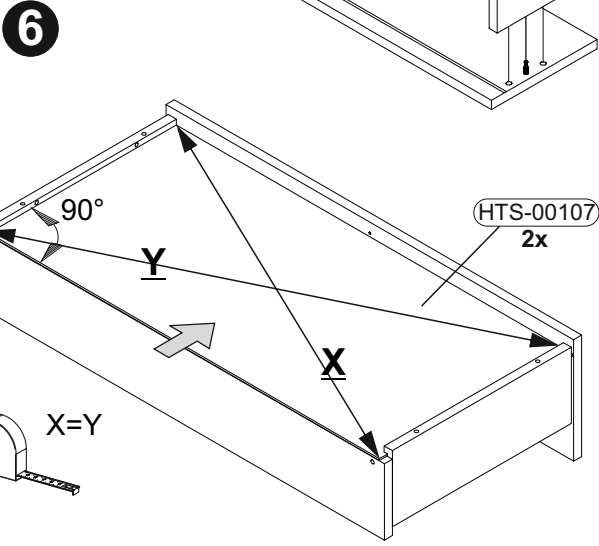
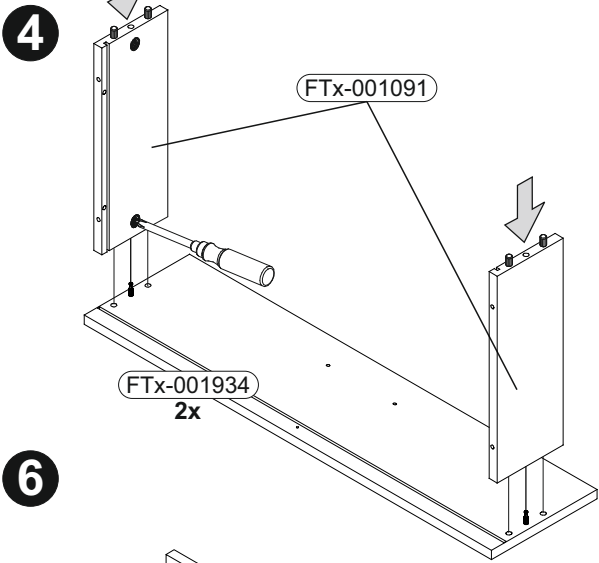
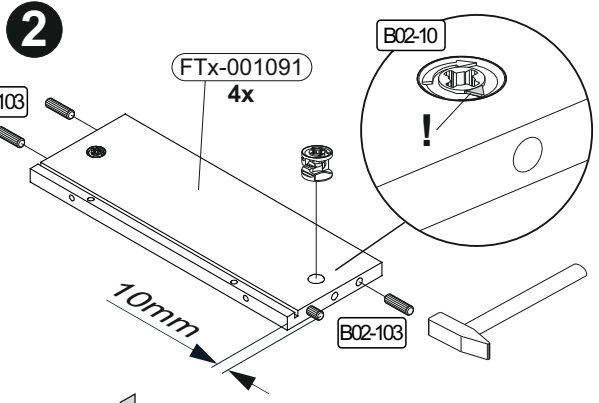
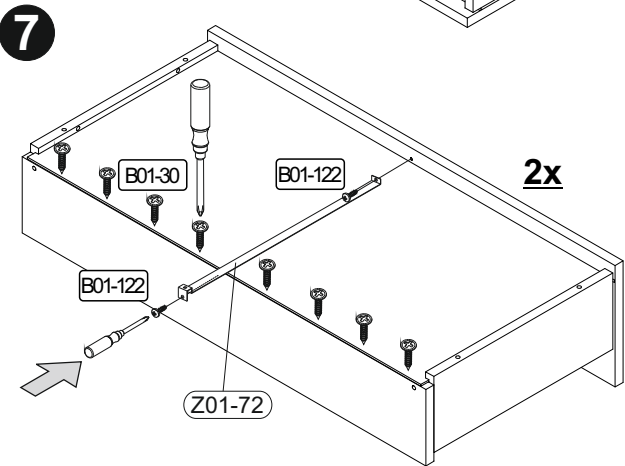
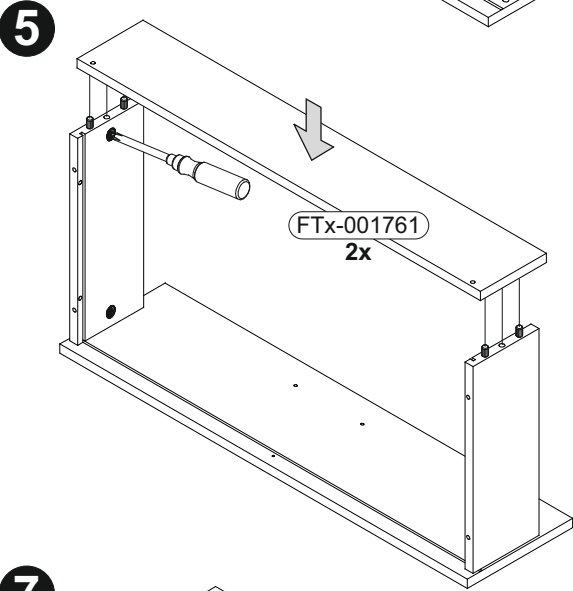
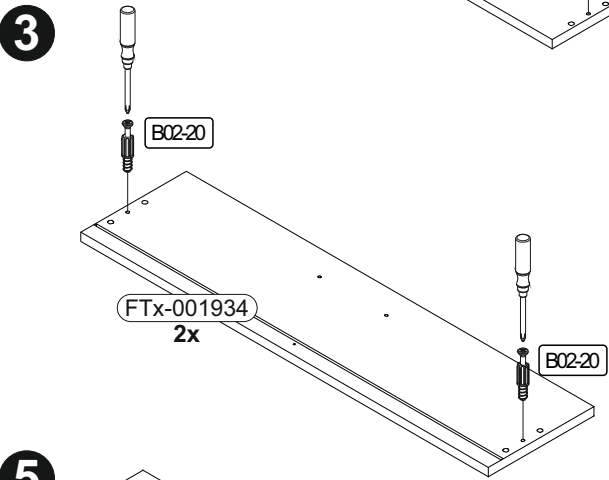
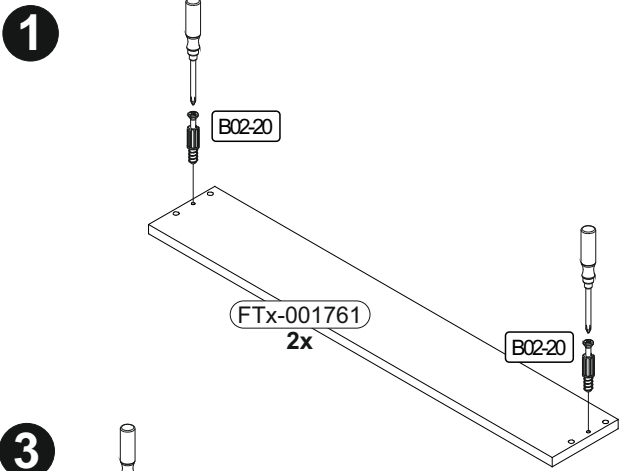



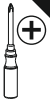
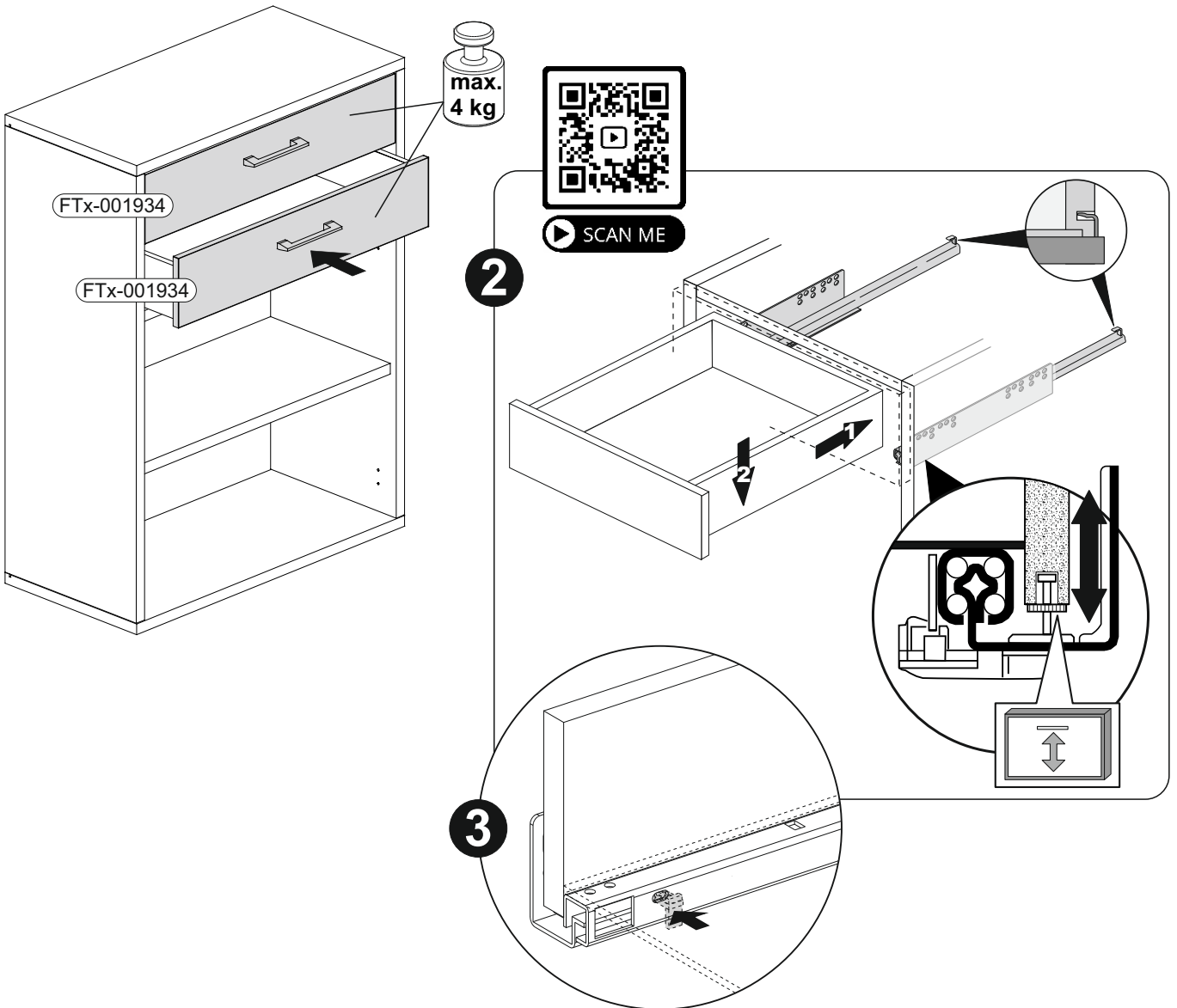
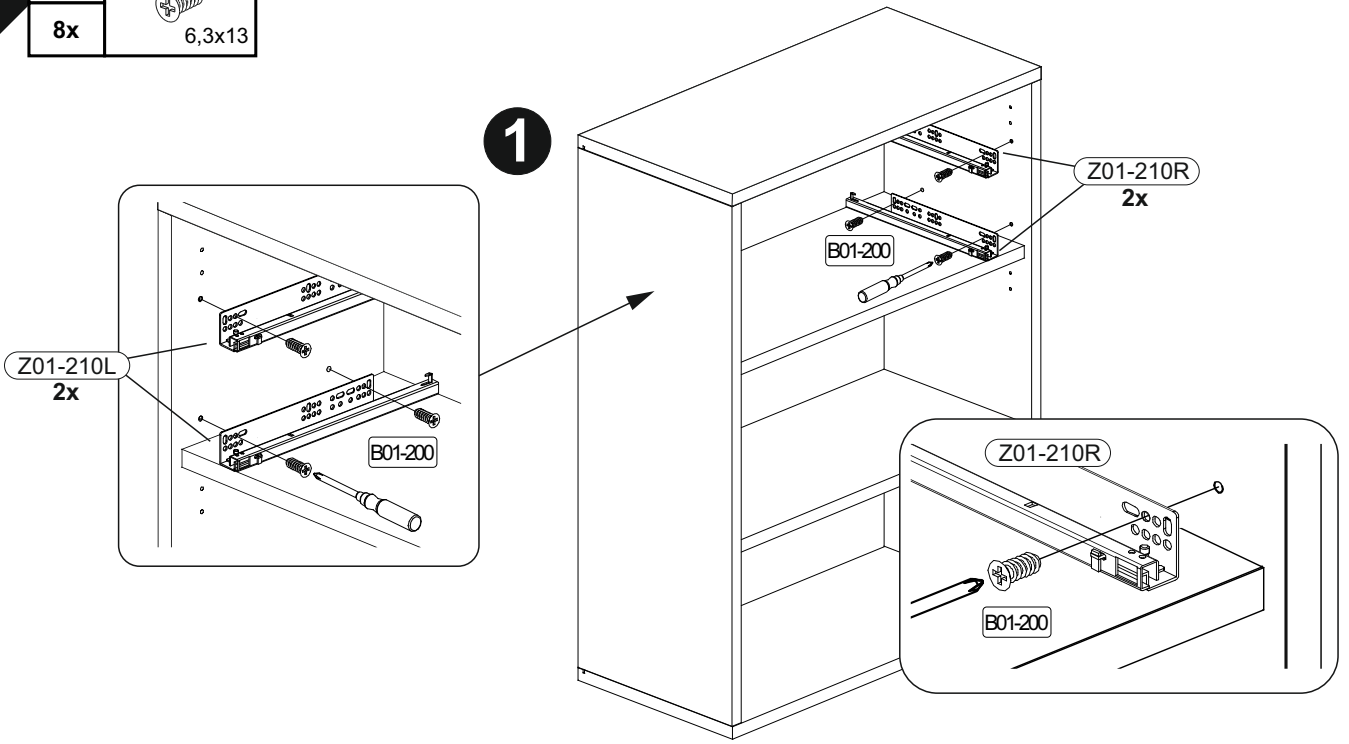

**4**

B01-200  
8x  
6,3x13

**5**

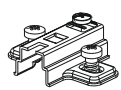
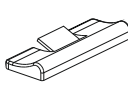

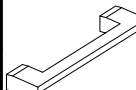
B03-11		B03-07		B01-329		B06-415		B01-37	
4x		2x		4x	M4x22	2x		1x	4,5x25

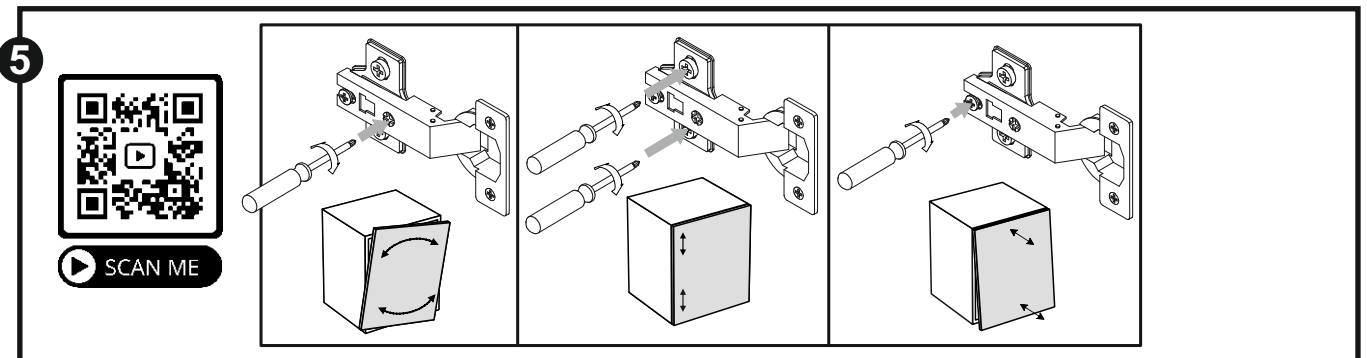
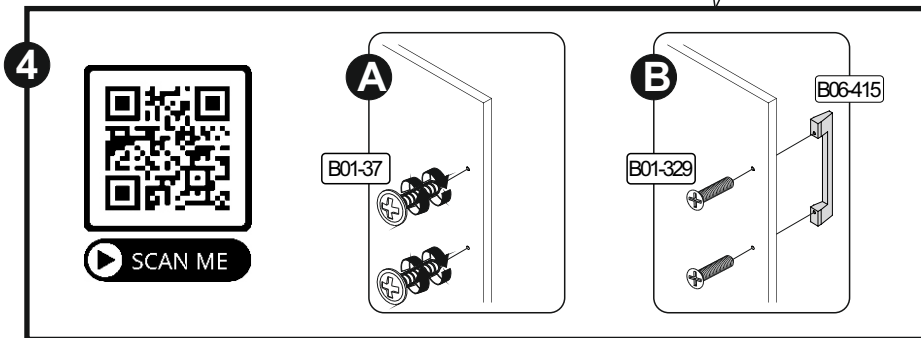
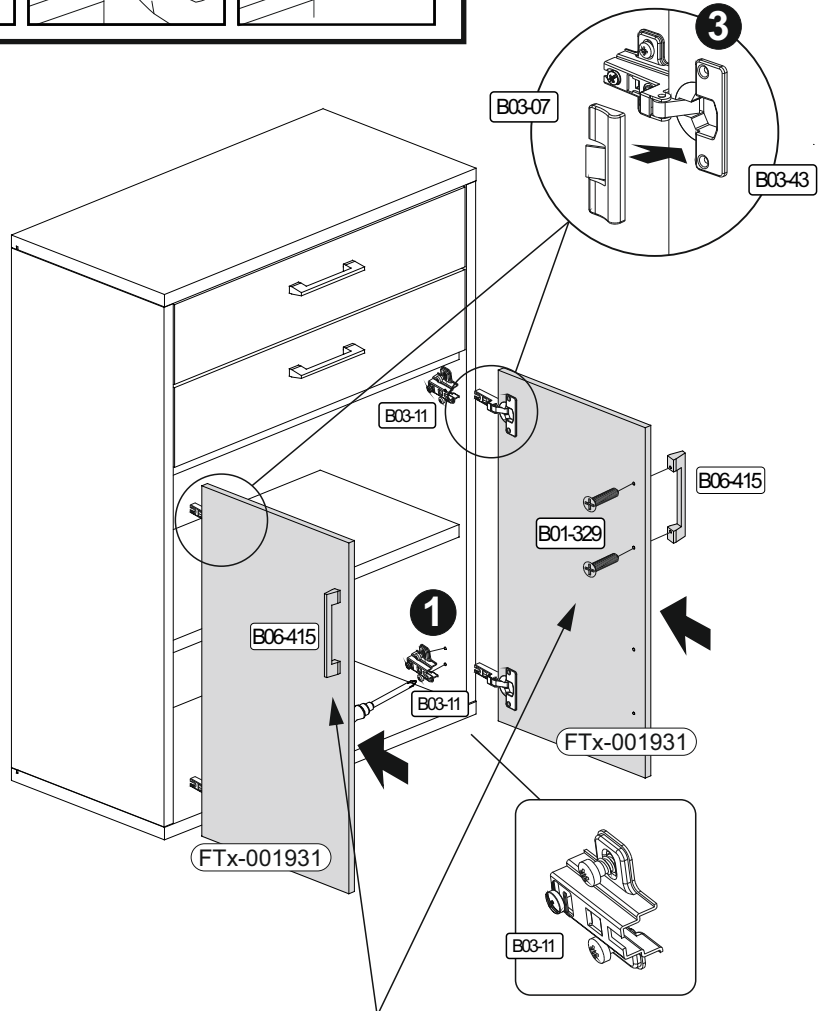
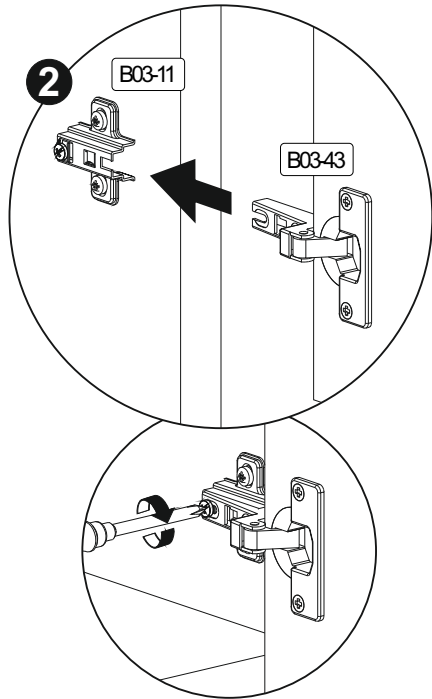
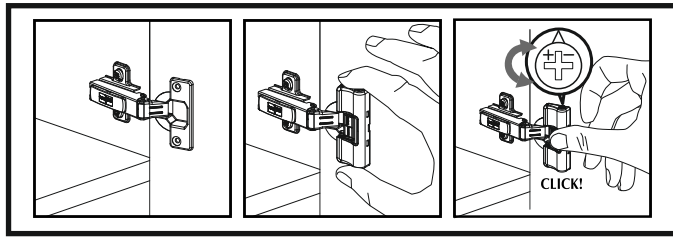

**6**

B01-200	
16x	6,3x13



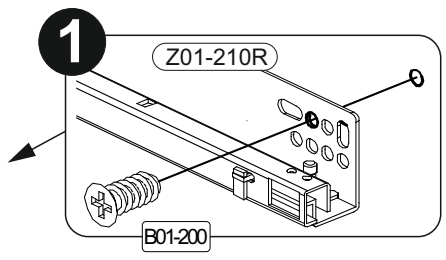
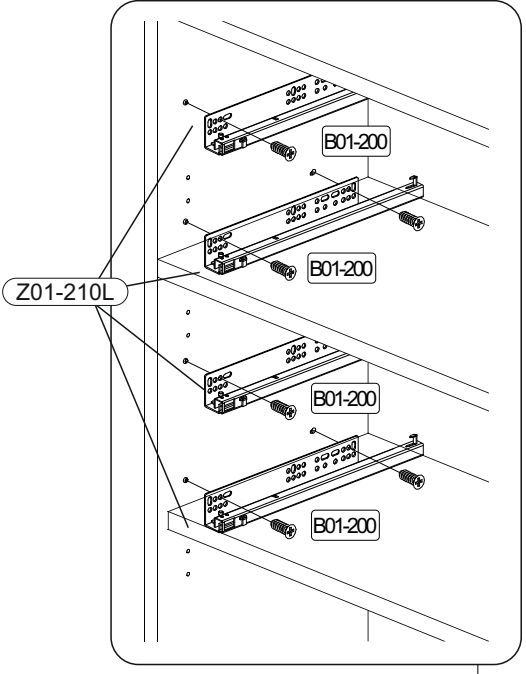
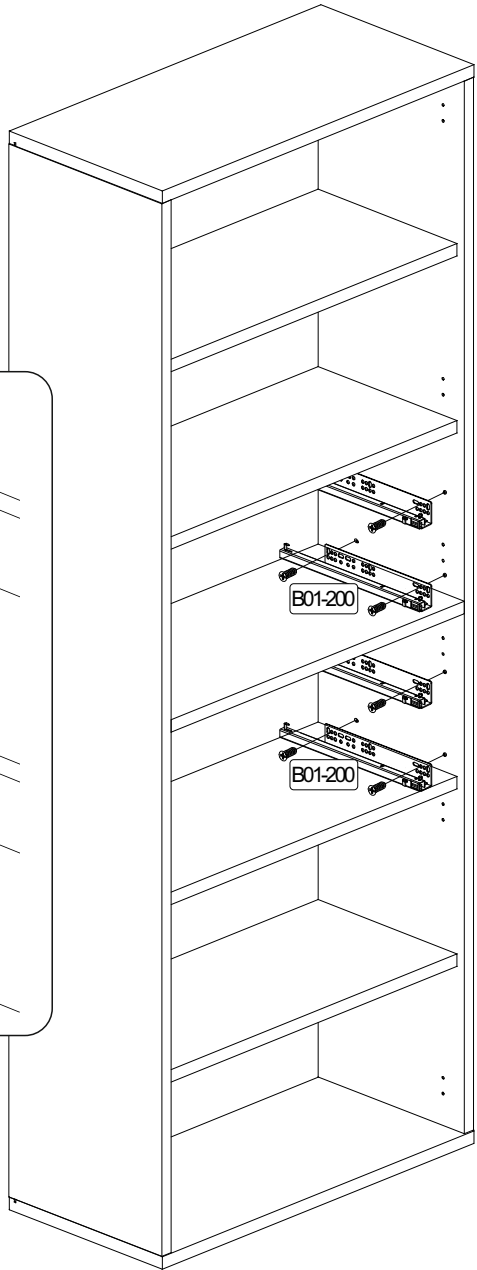

▶ SCAN ME

**2**

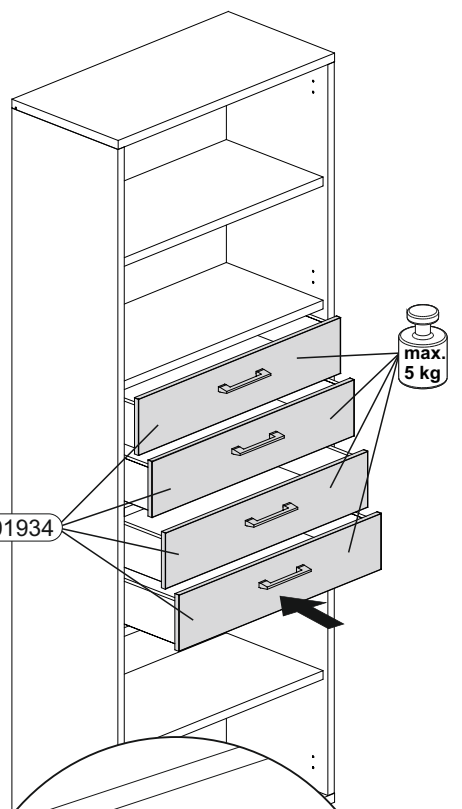
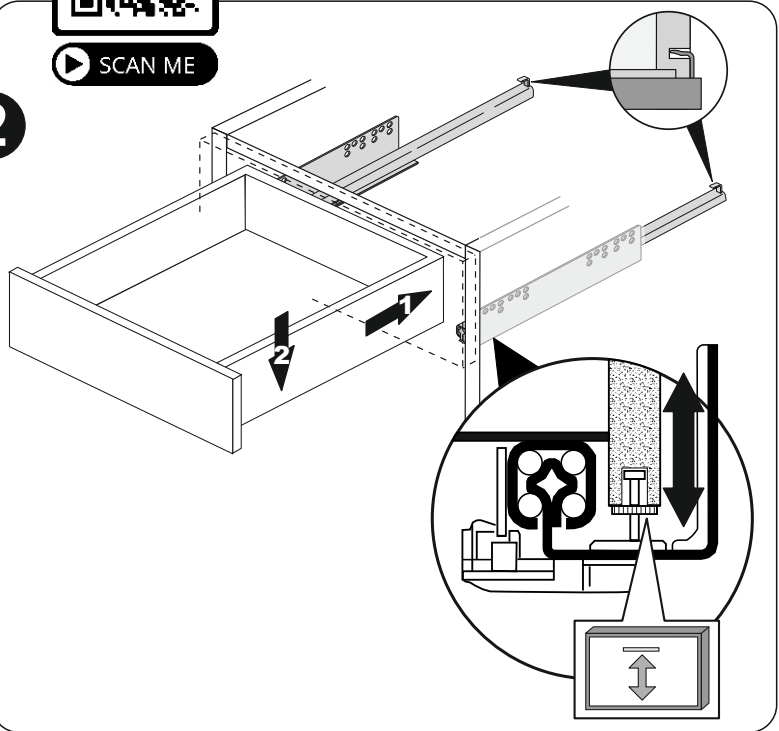

**3**

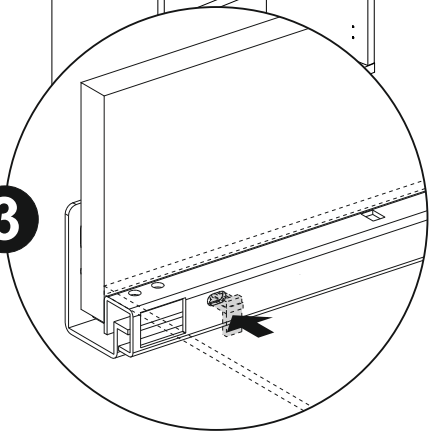

# 7

B03-11		B03-07		B01-329		B06-415		B01-37	
8x		4x		8x	M4x22	4x		1x	4,5x25

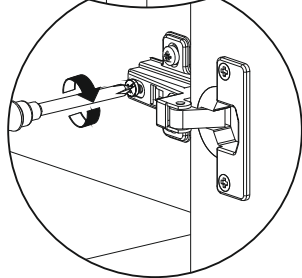
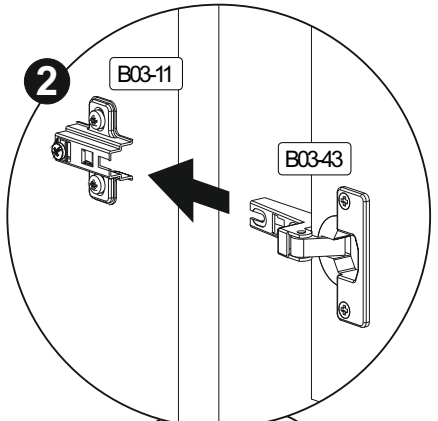
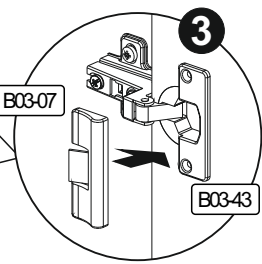
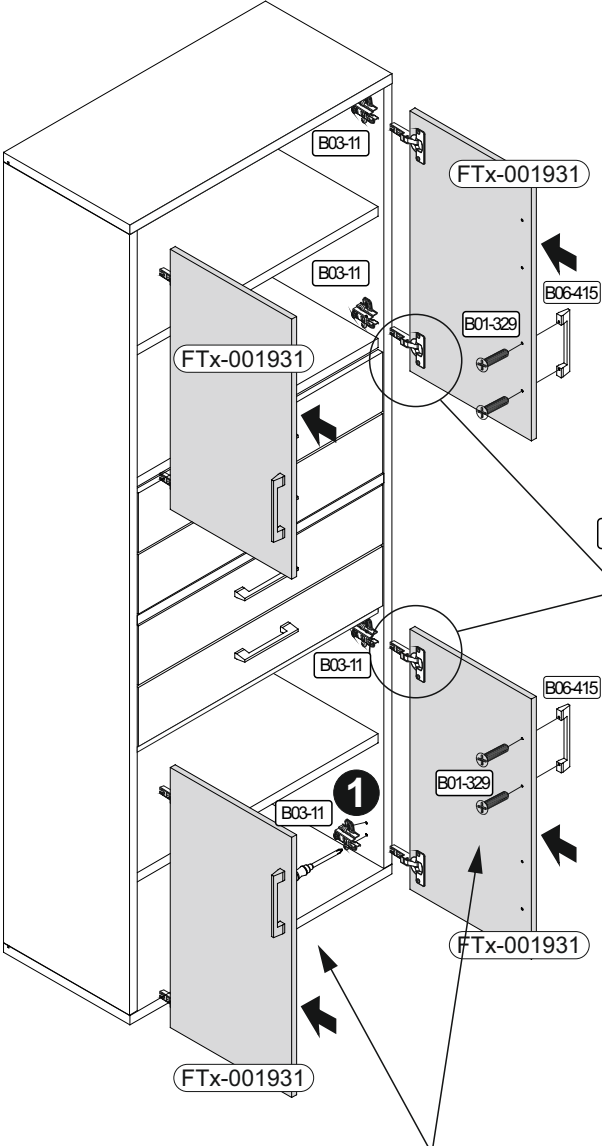
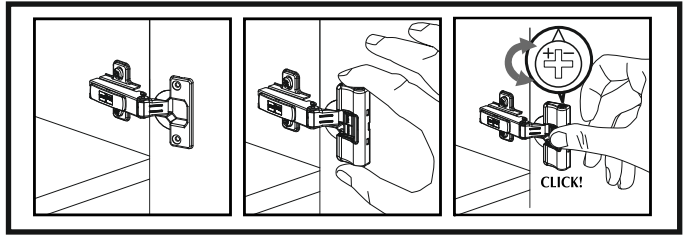

**4**

SCAN ME

**A**

**B**

**5**

SCAN ME