



Artikel.-Nr.:

4008-Wiko-03

Montageanleitung.-Nr.:

MA1-00837

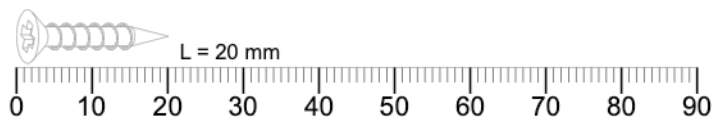
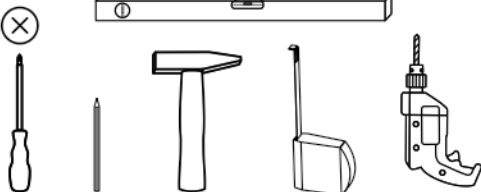
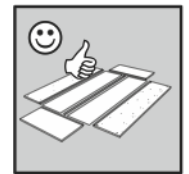
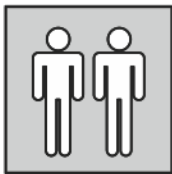
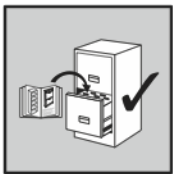

Das Ersatzteil-Anforderungsformular finden Sie auf
The replacement parts requisition form you find on
<https://www.maeusbacher.de/ersatzteile/>

BT1-00930

B01-122 12x 4x13		B01-200 30x 6,3x13		B01-30 30x 3x16	
B01-36 4x 4,0x40		B01-80 16x 3,5x13		B01-90 4x 3,5x20	
B02-103 32x 8x30		B02-169 10x ø12mm		B05-185 4x	
B08-80 1x		B02-10 40x ø15x12mm		B02-20 40x	

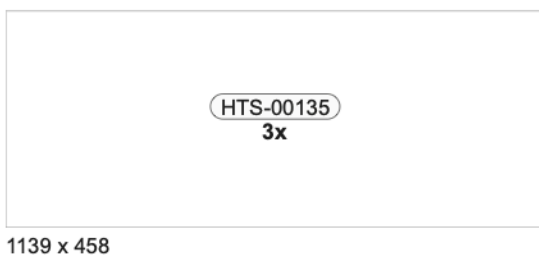
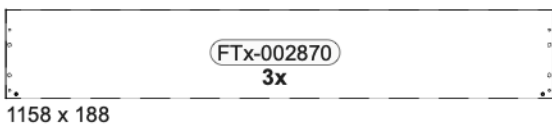
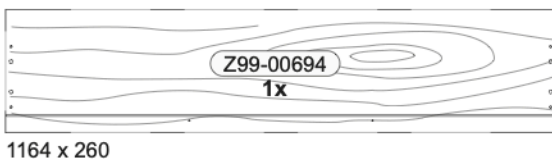
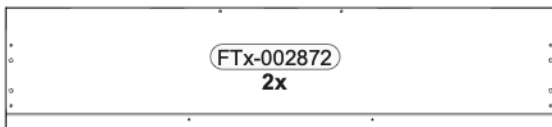
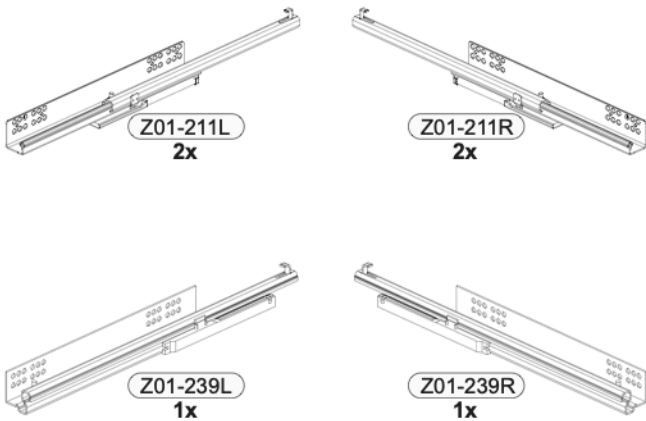

BT1-00931

B02-133 8x		B05-02 24x ø20mm	
B05-303 2x		B05-301 2x	
B05-302 2x		B06-423 2x 300mm	

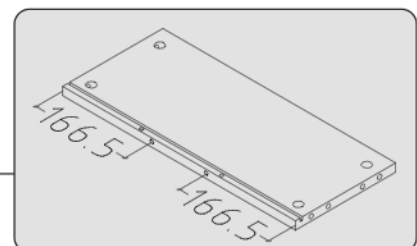
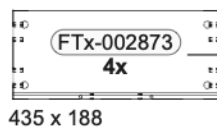
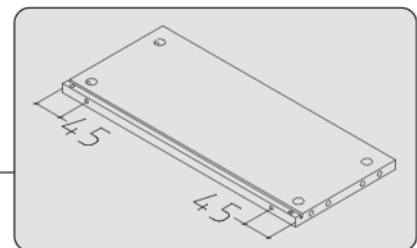
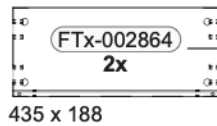
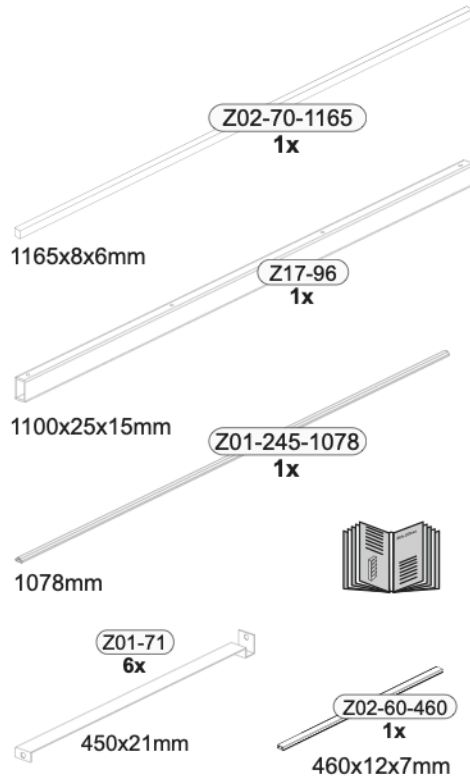

Colli 2/2

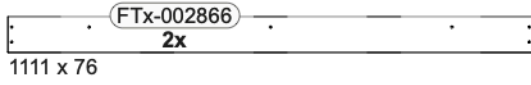
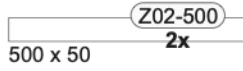
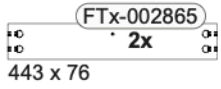

812 x 590

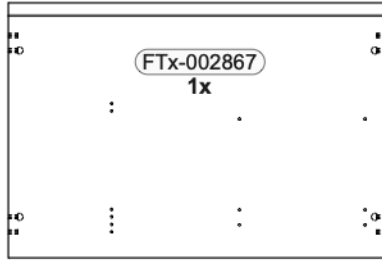
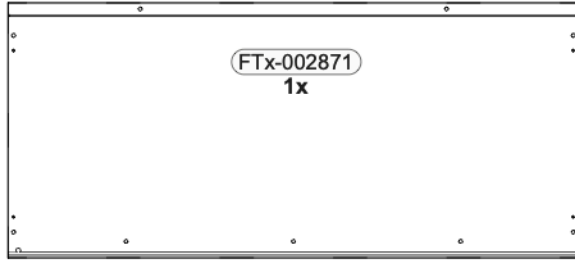

1208 x 540



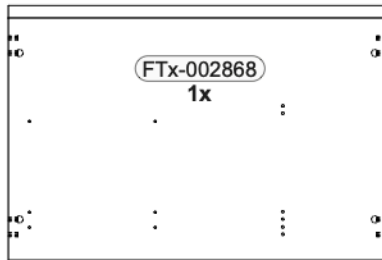
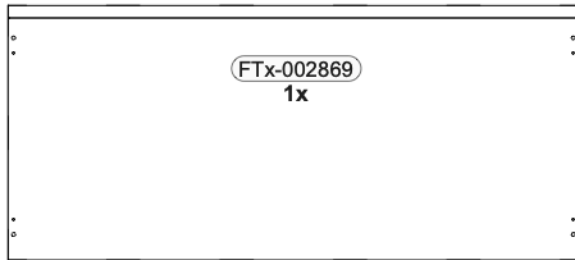

800 x 540



1208 x 540





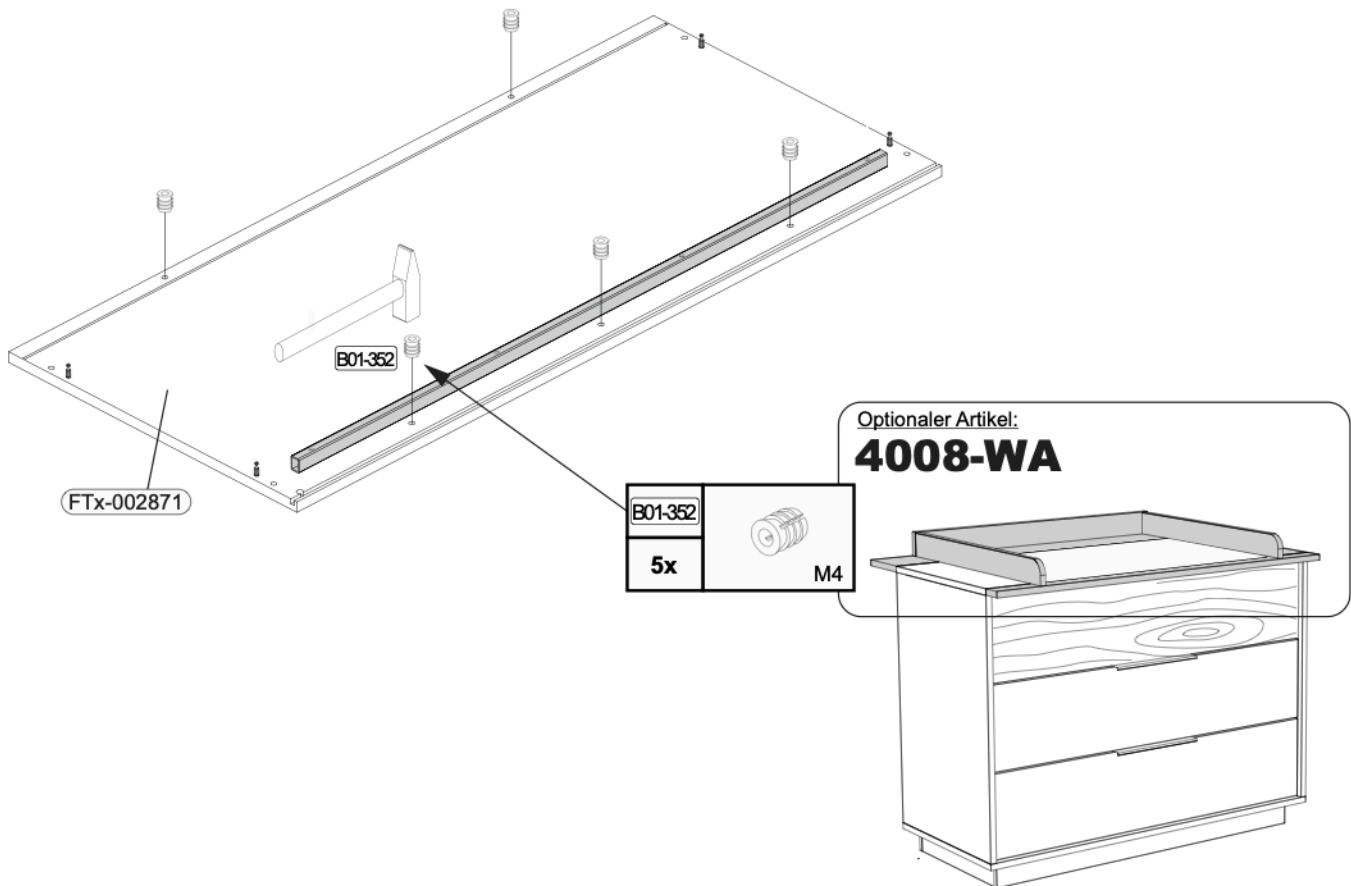
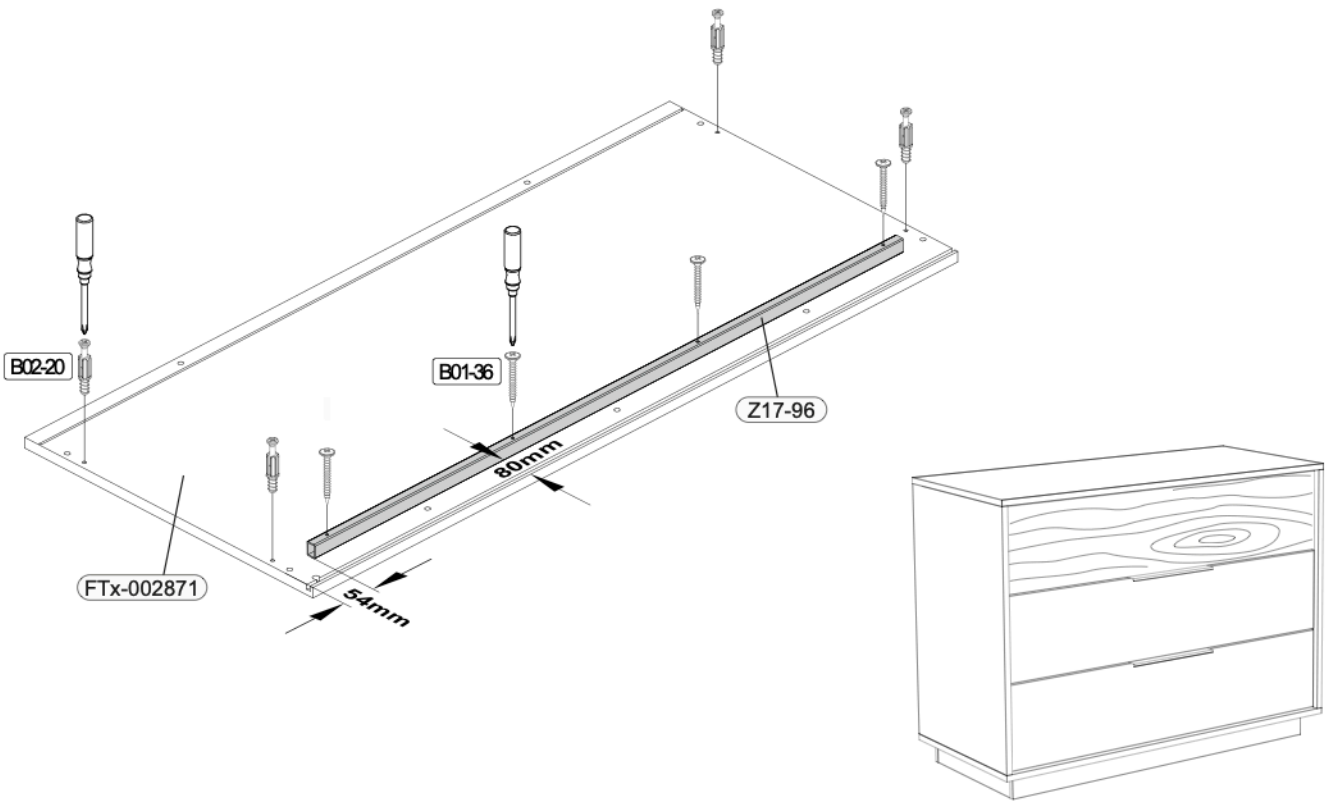

800 x 540

1

		B02-20		B01-36	
		4x		4x	4,0x40





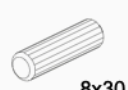

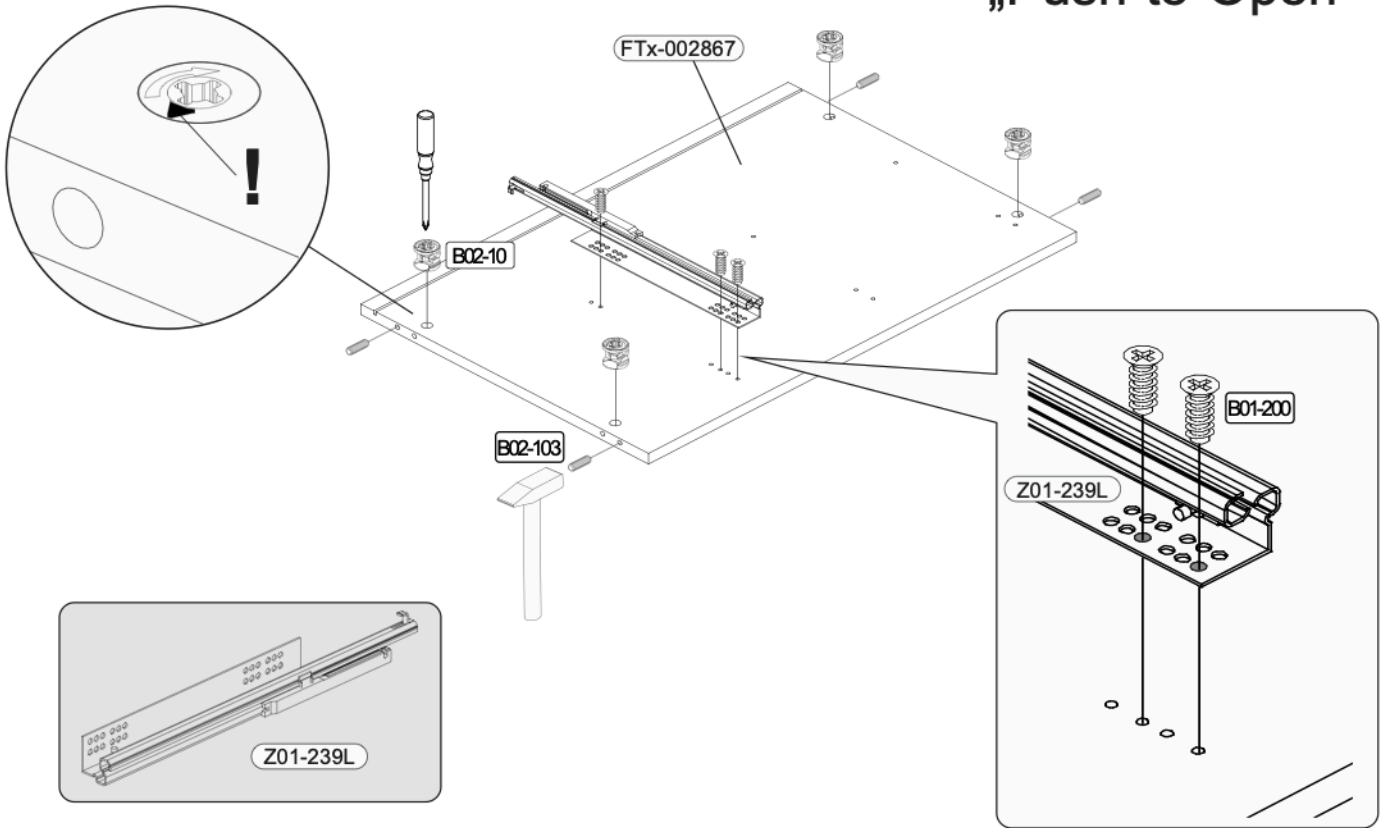

2

 + 					
3x	6,3x13	4x	ø15x12mm	4x	8x30

„Push-to-Open“

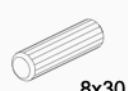

3

 + 					
3x	6,3x13	4x	ø15x12mm	4x	8x30

„Push-to-Open“

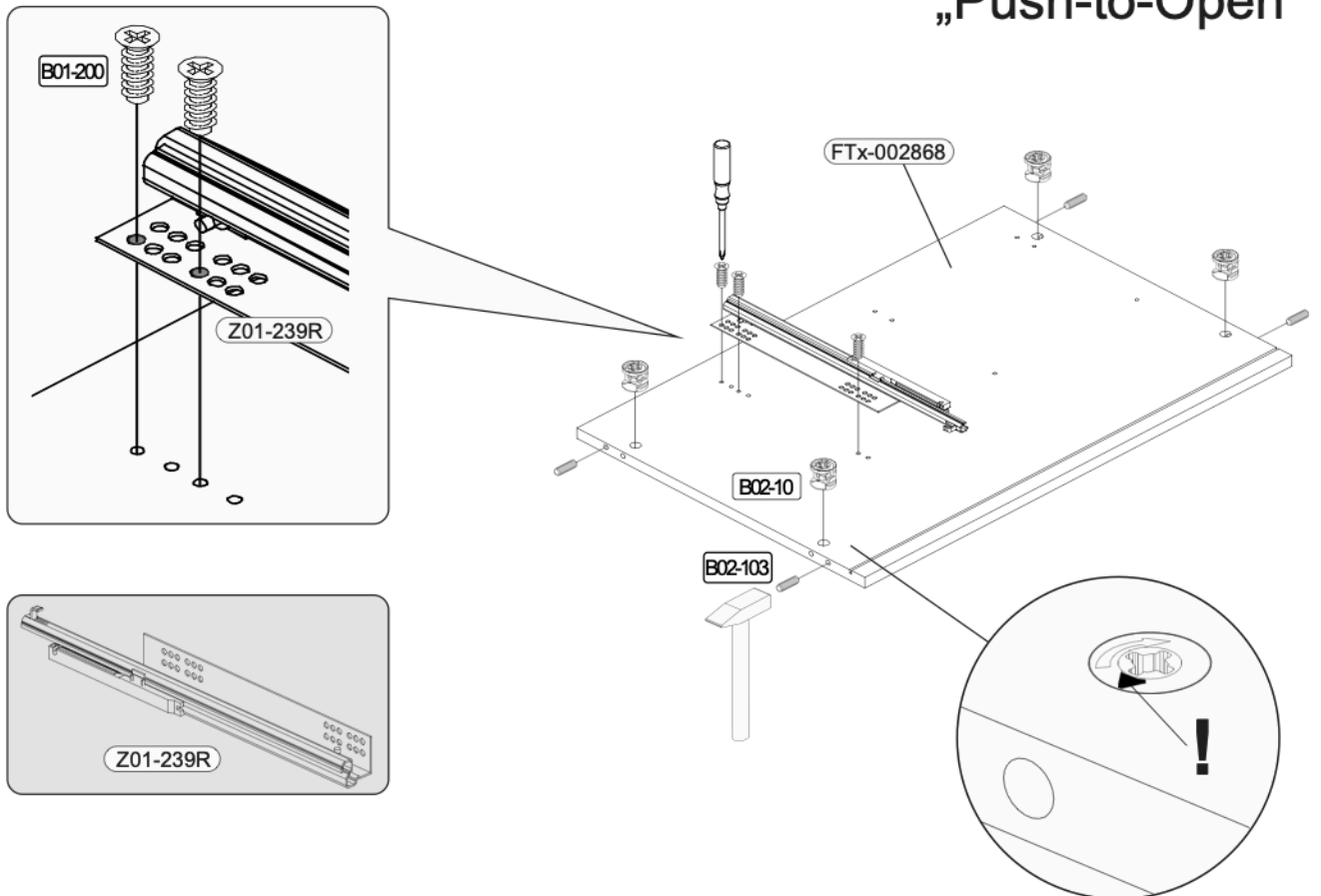

4



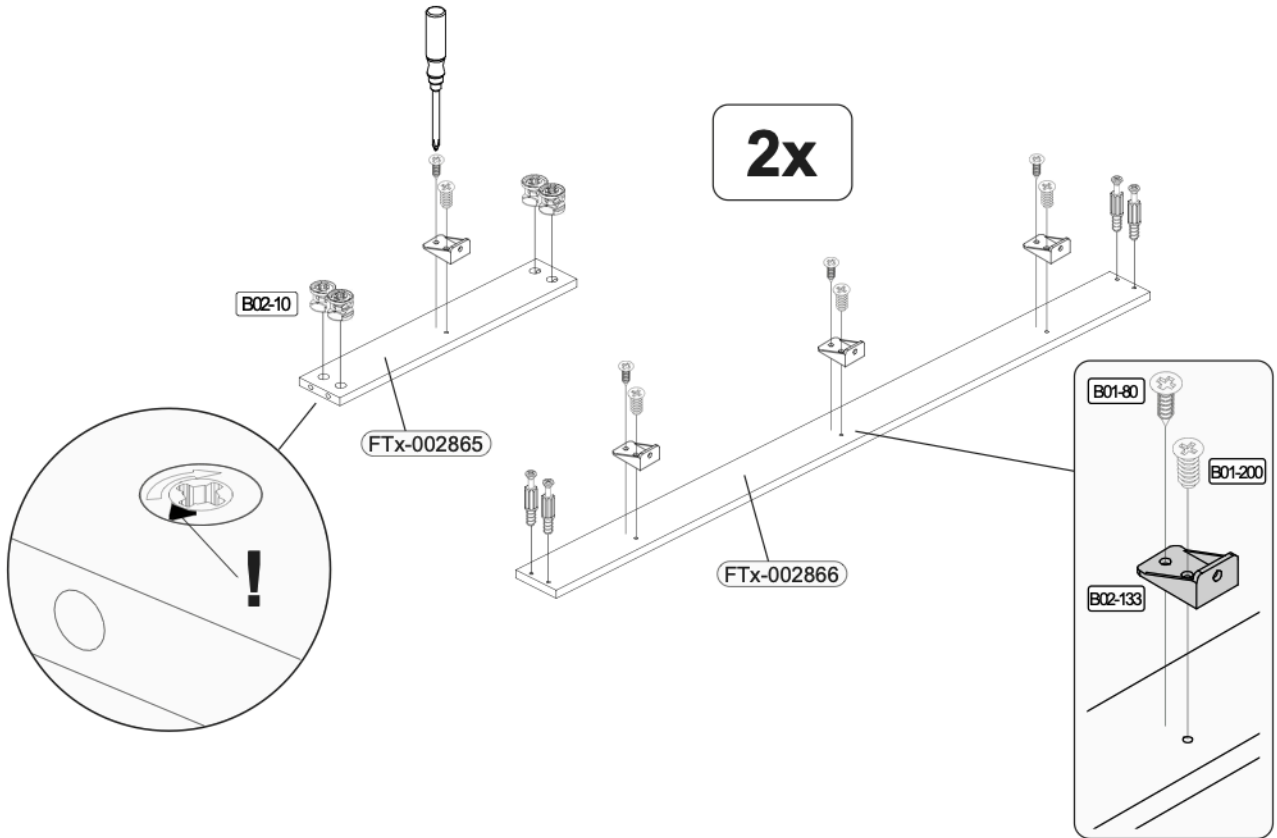



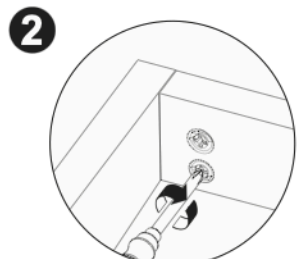
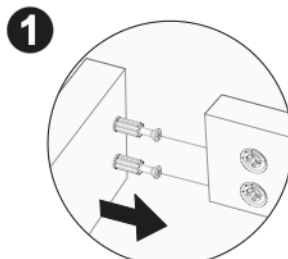
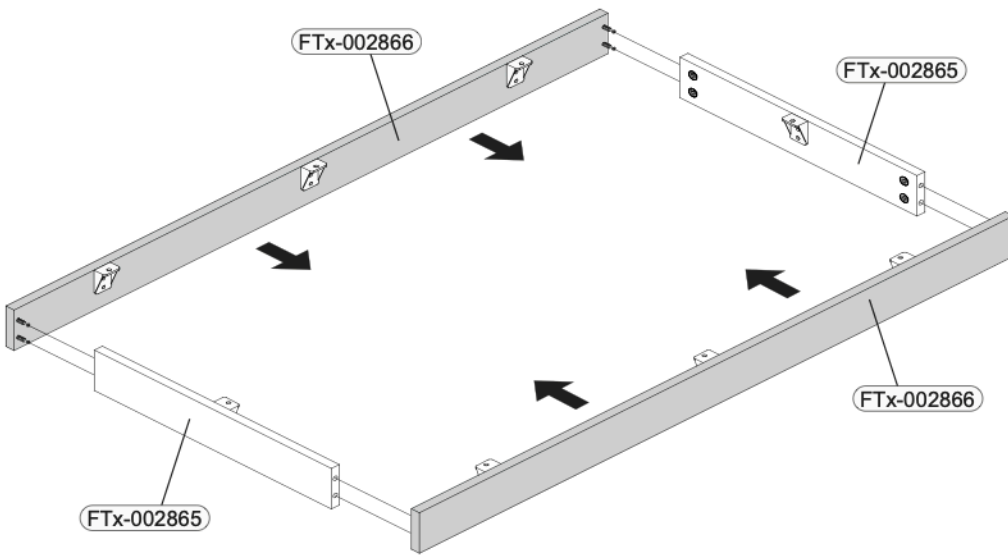
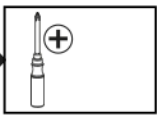

	B02-10		B01-200		B01-80		B02-133		B02-20	
	8x	$\varnothing 15 \times 12 \text{mm}$	8x	6,3x13	8x	3,5x13	8x		8x	



5



6

							
		8x	3,5x13	10x		4x	

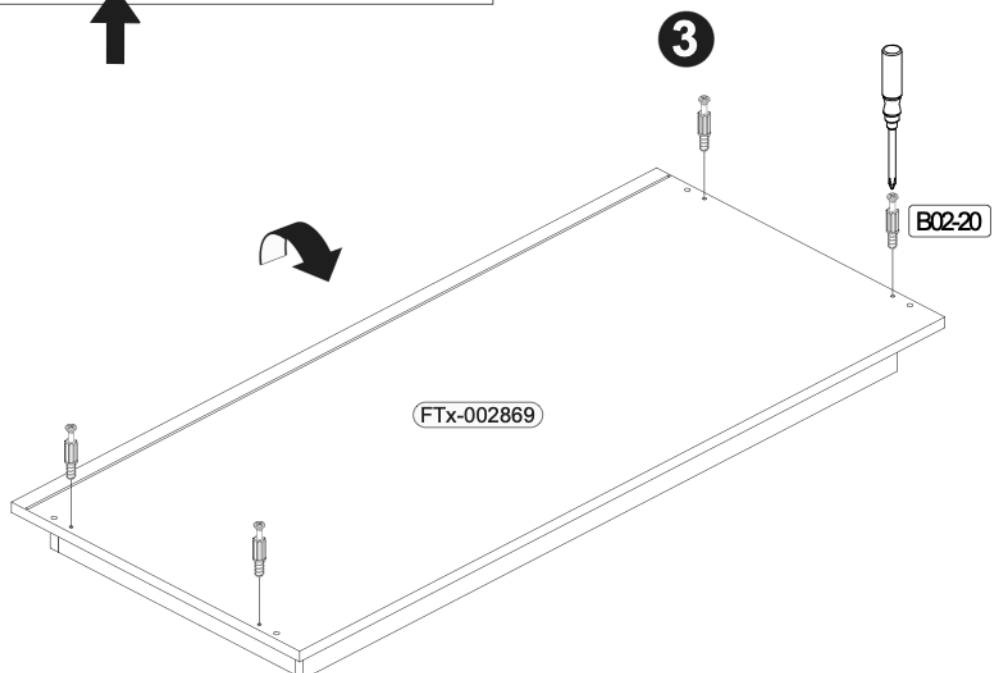
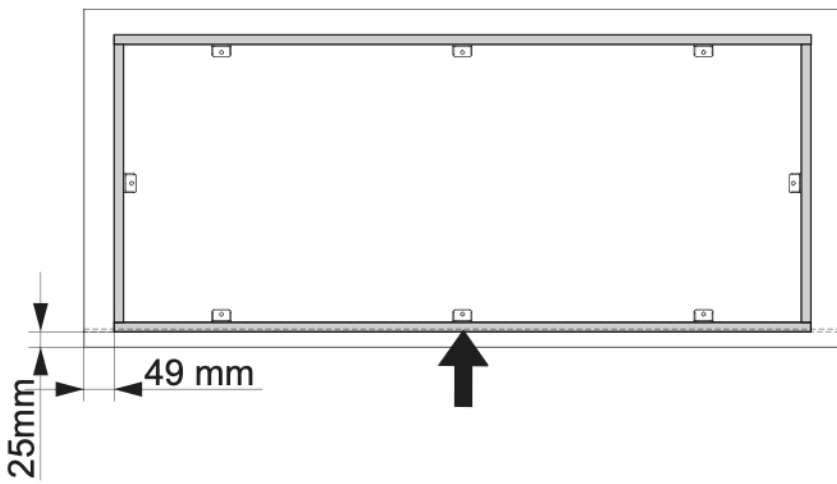
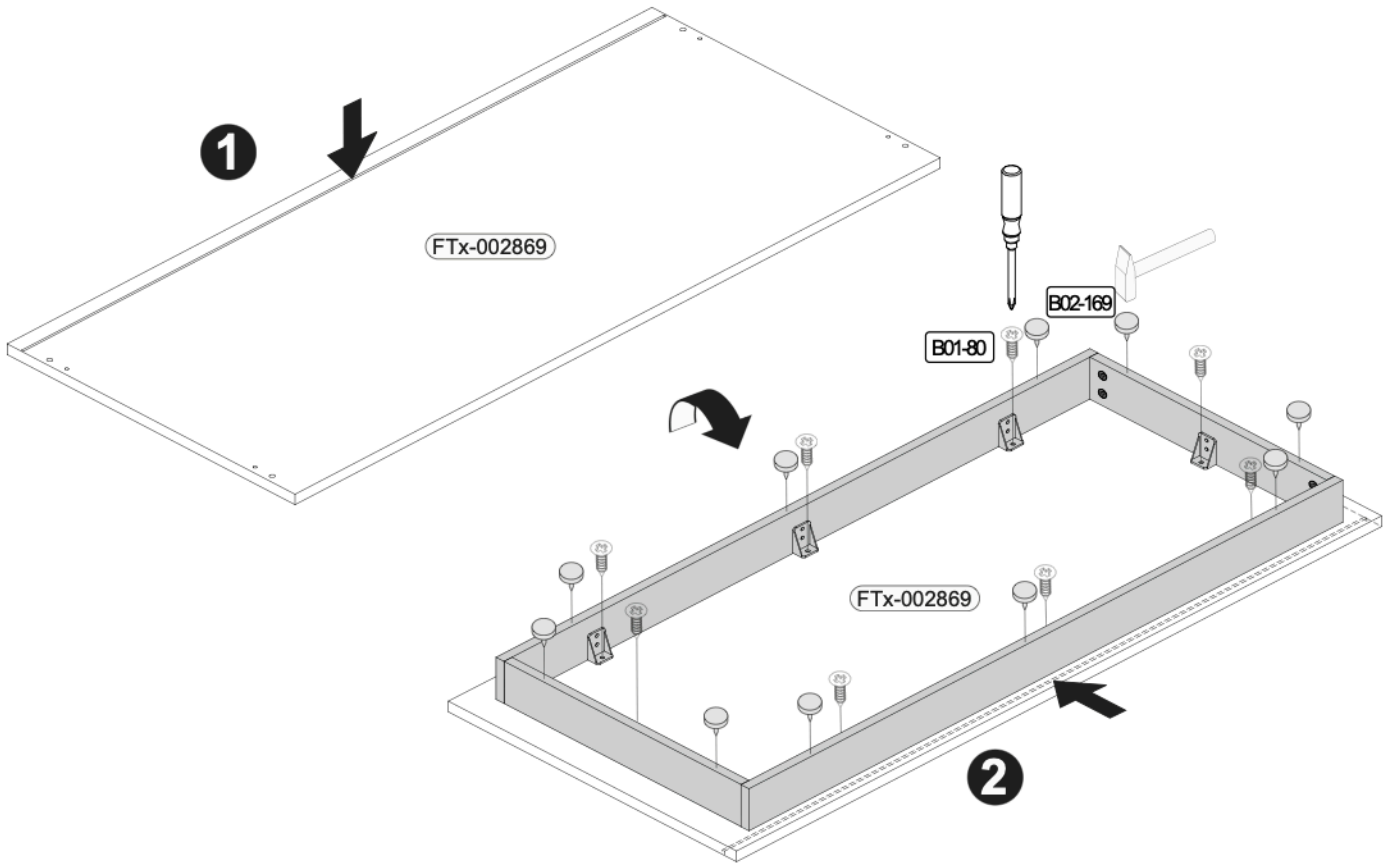

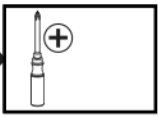
7 

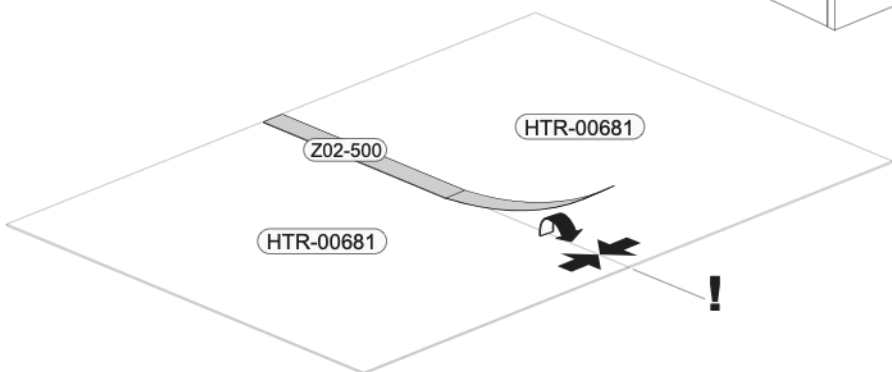
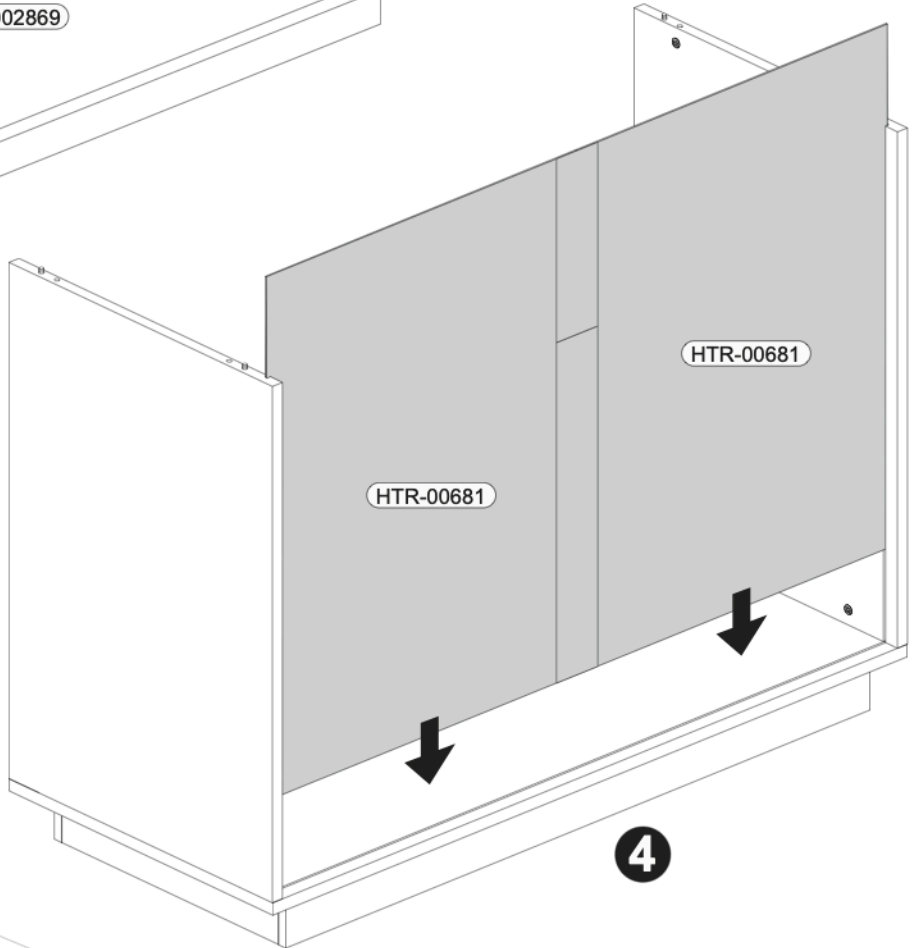
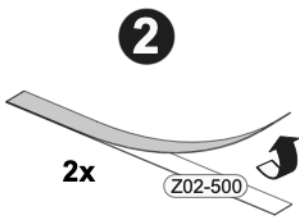
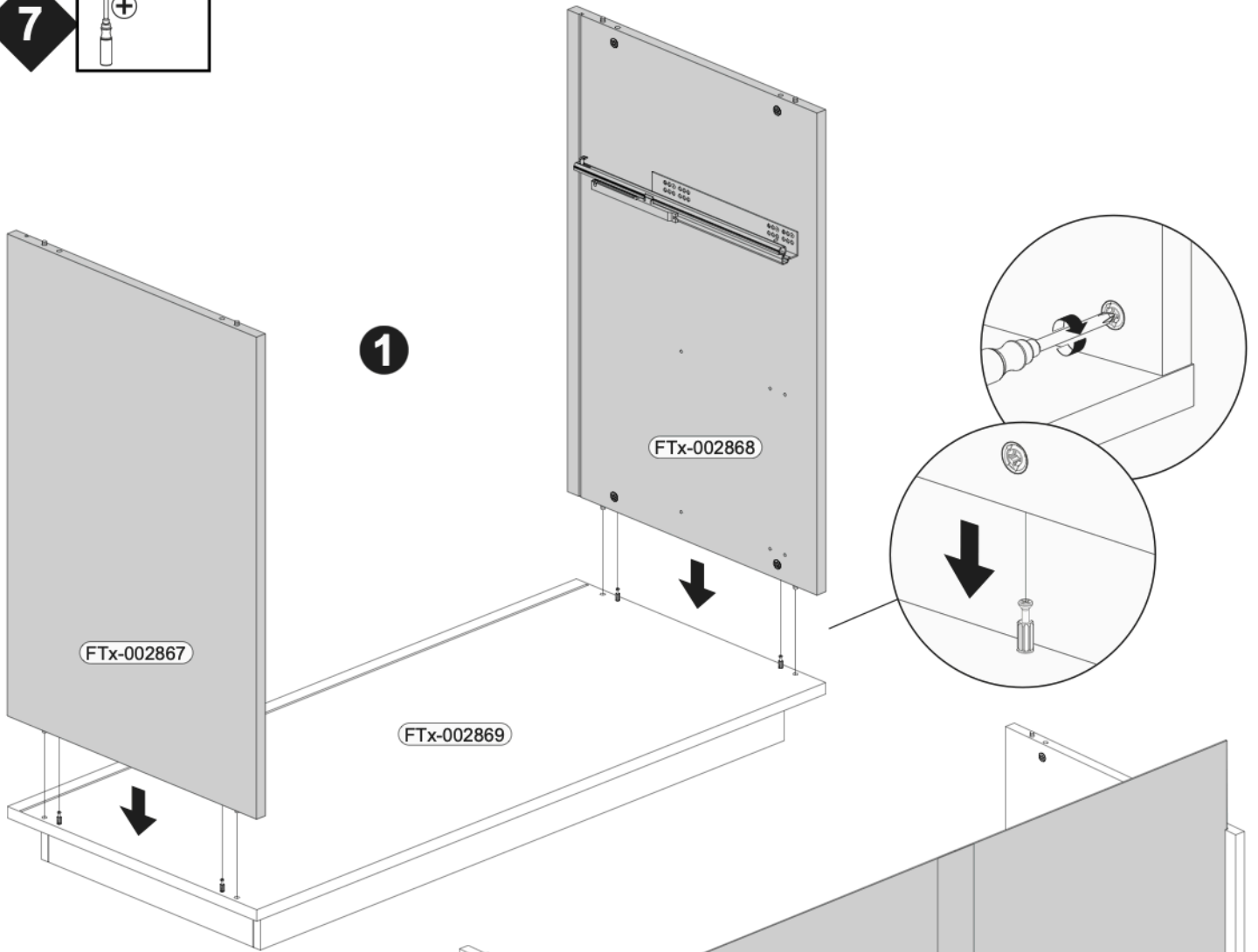

8

	B05-185		B01-90	
	4x		4x	3,5x20

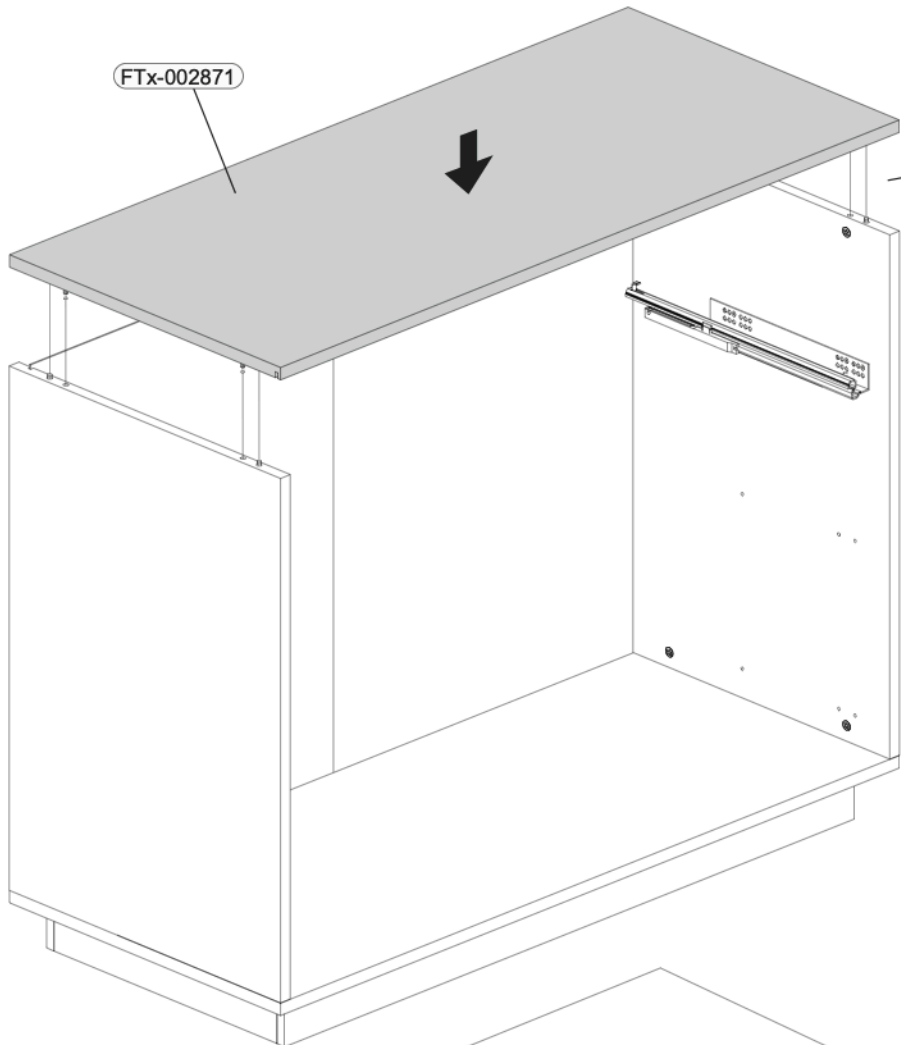

1

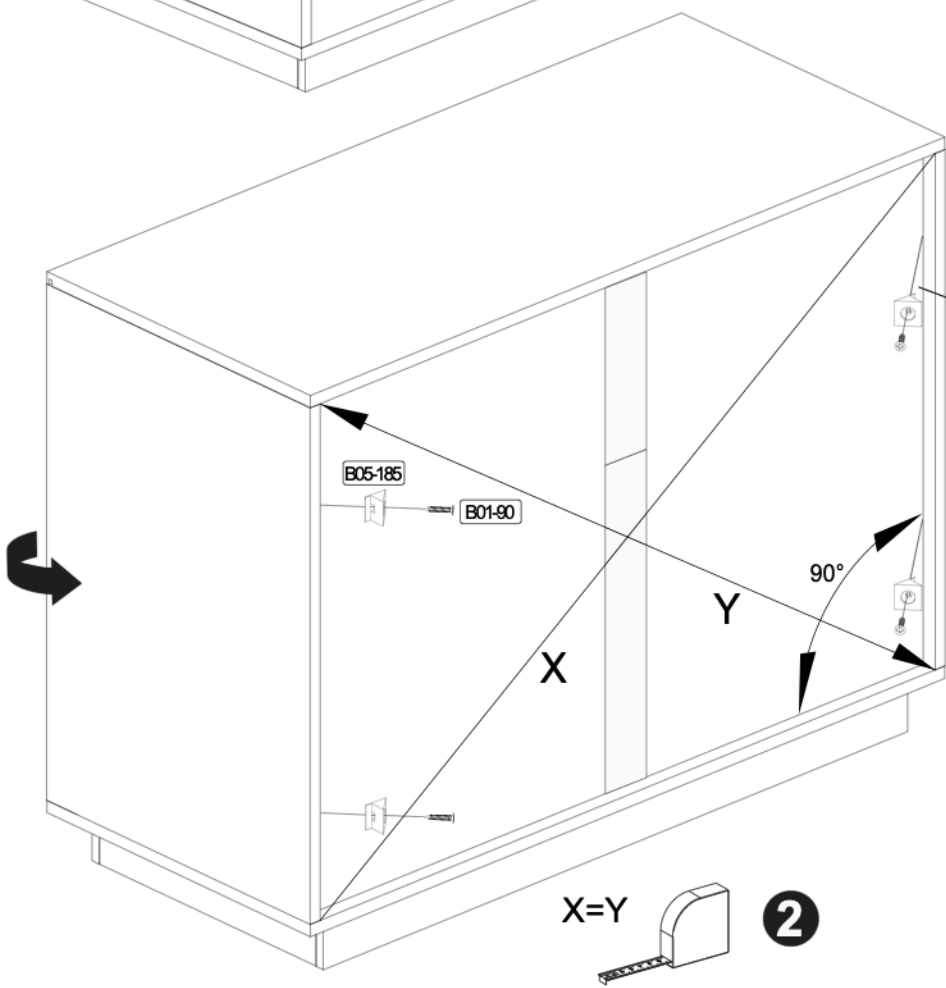
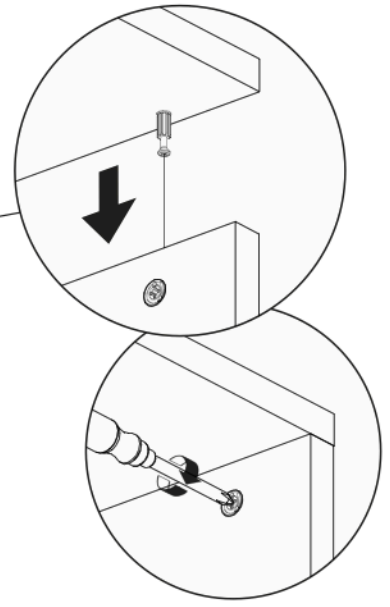

3

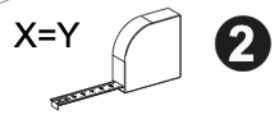
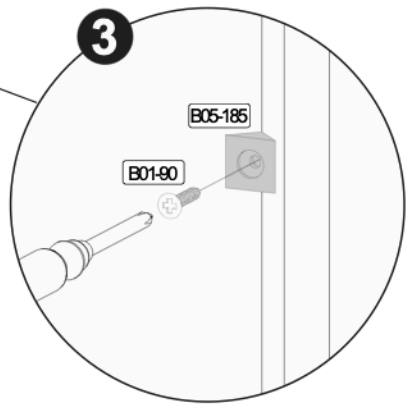

9

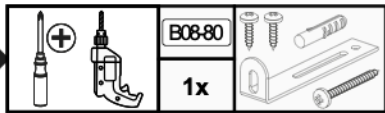

2

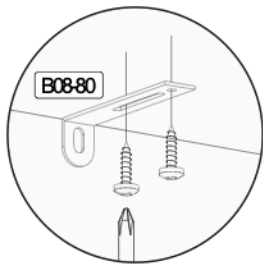



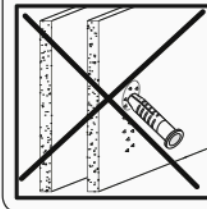
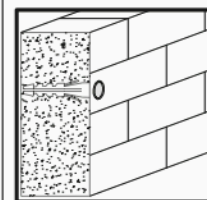
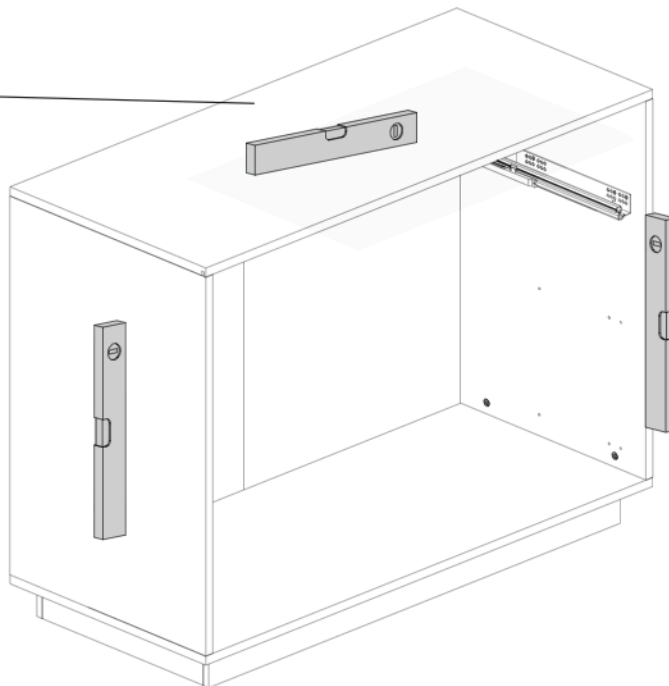
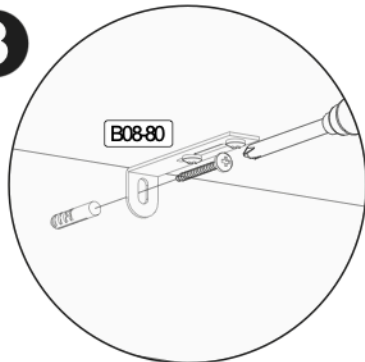





3



Achtung • Attention • Attenzione • Opgelet • Uwaga • Pozor • Figelem • Atenție • Dikkat • Внимание • Fara • Vaara • Fare • Peligro	
(D)	Wandbefestigung dient als Kippschutz - unbedingt anbringen! Bei einigen Wandtypen kann ein Spezialdübel erforderlich sein!
(GB)	The wall fastening serves to prevent tipping - be absolutely sure to mount it! For certain wall types, a special wall plug may be necessary!
(FR)	La fixation murale sert de protection contre le basculement – à installer impérativement ! Pour certains types de murs il faut des chevilles spéciales !
(TR)	Duvardaki sabitleme, devrilmeye karşı bir emniyet tedbiridir ve mutlaka monte edilmelidir! Bazı duvar tiplerinde bunun için özel bir dübel gerekli olabilir!
(IT)	Il fissaggio alla parete serve da protezione anti-ribaltamento – attaccarla assolutamente! Per alcune strutture di parete può essere necessario un tassello speciale!
(NL)	Bevestiging aan de muur dient als kantelbescherming – zeker en vast bevestigen! Bij enkele muurtypes is een speciale plug misschien vereist!
(RU)	Обязательно установите крепление на стене во избежание опрокидывания! Для некоторых типов стен может потребоваться специальный дюбель!
(CZ)	Montáž na stěnu slouží jako ochrana proti převrnutí – bezpodmínečně umístěte! U některých typů stěn může být zapotřebí speciální hmoždinka!
(HU)	A termék a falhoz kel rögzíténi, különben az felborulhat! Egyes faltípusoknál speciális tiplit kell használni!
(RO)	Sistemul de fixare la perete servește ca protecție la răsturnare - de montat obligatoriu! Pentru unele tipuri de pereți este posibil să fie necesar un diblu special!
(PL)	Mocowanie do ściany jest jednocześnie zabezpieczeniem przed przewróceniem – koniecznie zamontować! Do niektórych rodzajów ścian koniecznie zastosować specjalne kołki mocujące.
(SWE)	Väggmontering fungerar som anti-lutnings skydd - det är viktigt att fästa det! En speciell plugg kan behövas för vissa väggtyper!
(FIN)	Seinäkiinnitys toimii kaatumista estävänä suojana - se on ehdottomasti kiinnitettävä! Joihinkin seinätyypeihin voidaan tarvita erityistappi!
(NOR)	Veggmontering fungerer som anti-vippebeskyttelse - det er viktig å feste det! En spesiell dyvel kan være nødvendig for noen veggtyper!
(DAN)	Vægmontering fungerer som anti-vip beskyttelse - det er vigtigt at fastgøre det! En speciel dyvel kan være påkrævet til nogle vægtyper!
(SK)	Upevnenie na stenu slúži ako ochrana proti prevráteniu – bezpodmienečne použite! Pre niektoré druhy stien môže byť potrebná špeciálna hmoždinka!
(ES)	El montaje en la pared sirve como protección antivuelco: ¡es imprescindible fijarlo! ¡Es posible que se requiera una espiga especial para algunos tipos de paredes!

10

 +								
		16x	16x	ø15x12mm 16x	8x30 20x	3x16	8x	4,0x13

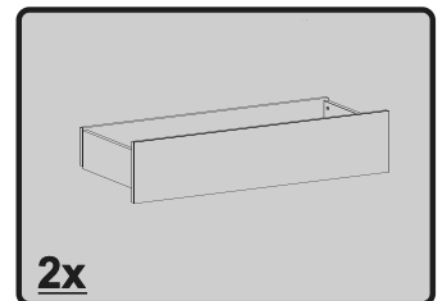
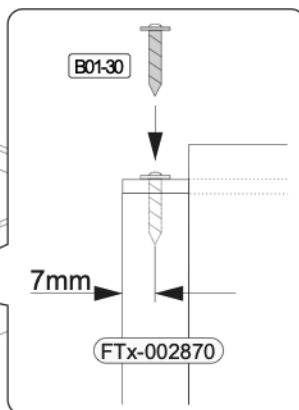
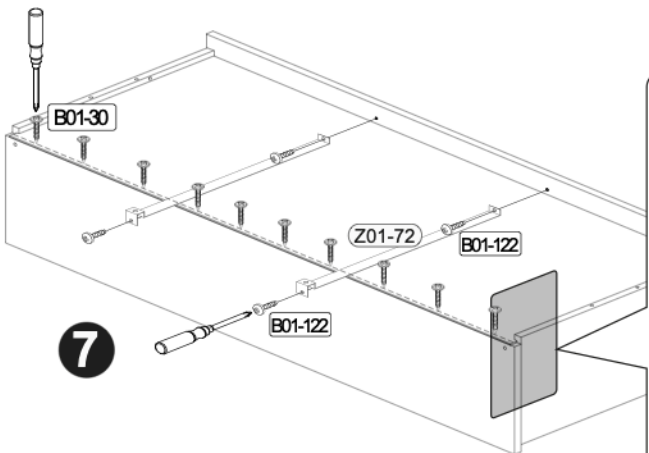
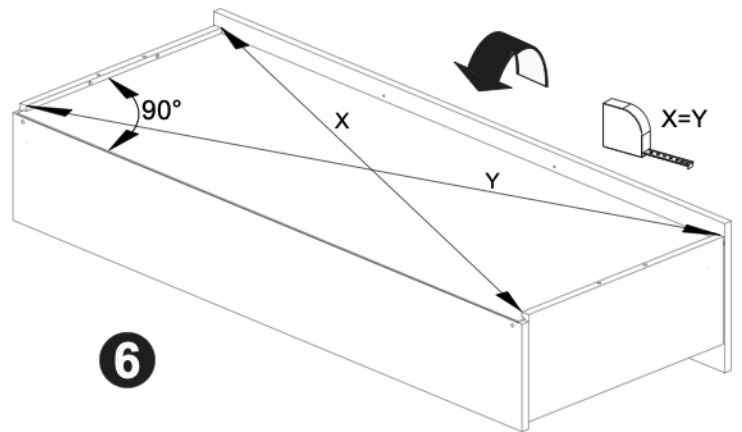
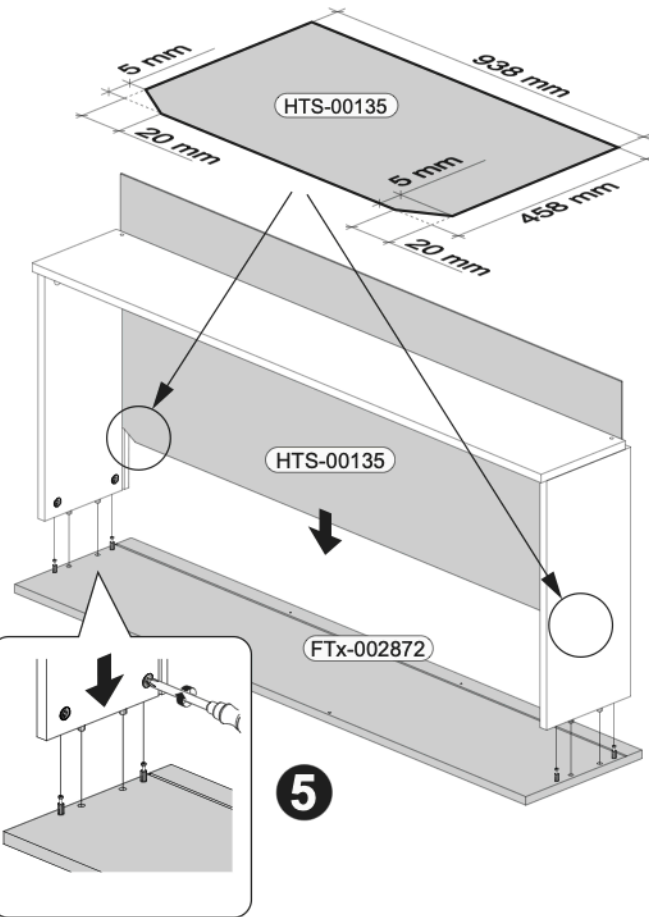
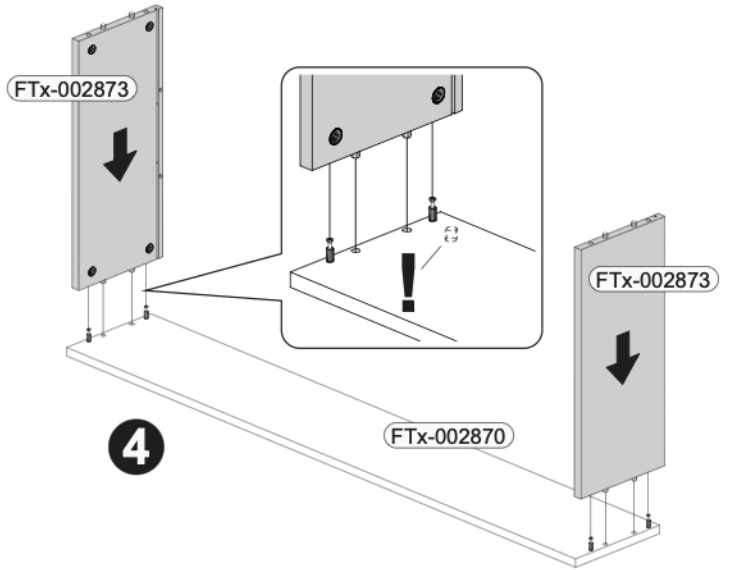
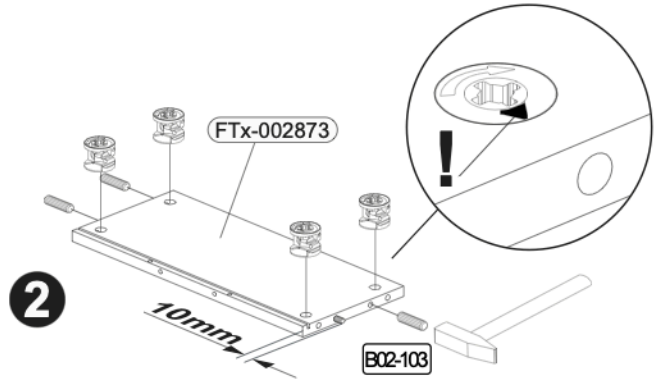
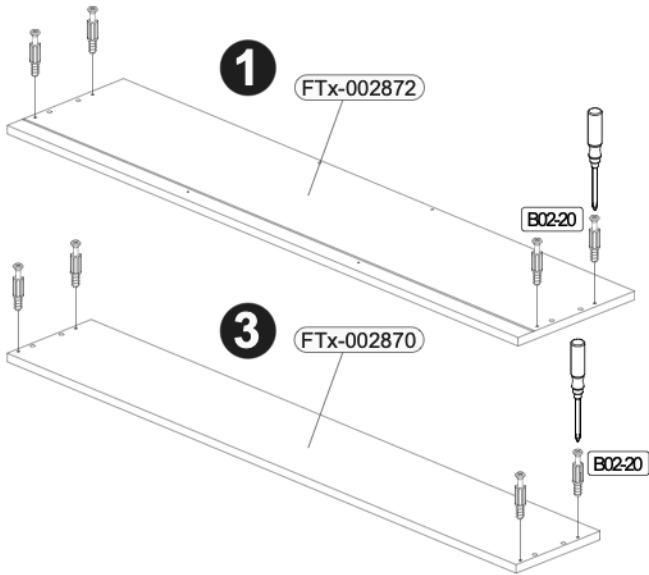

11

	B06-423		B01-200		B05-02		B05-301		B05-302	
	2x	300mm	16x	6,3x13	16x	ø20mm	2x		2x	

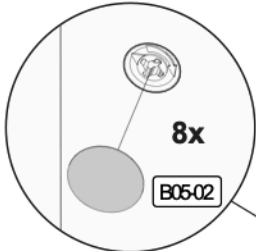
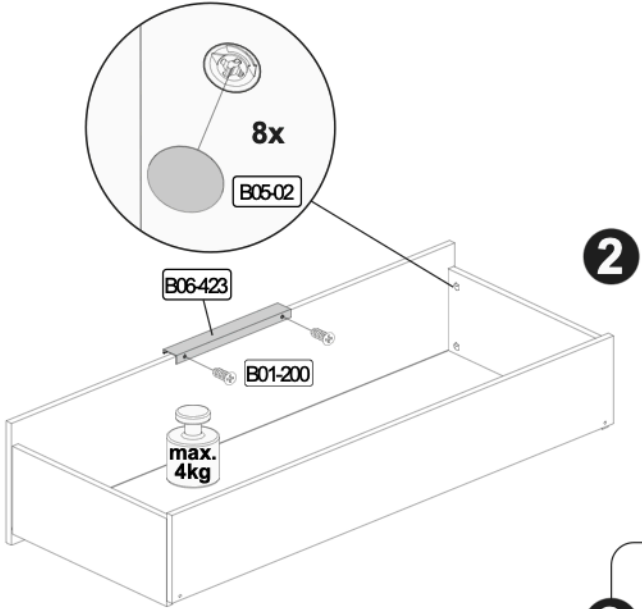
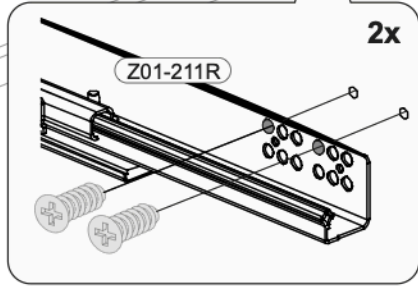
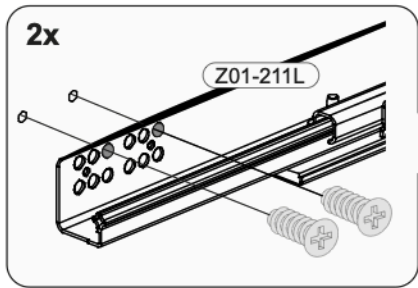
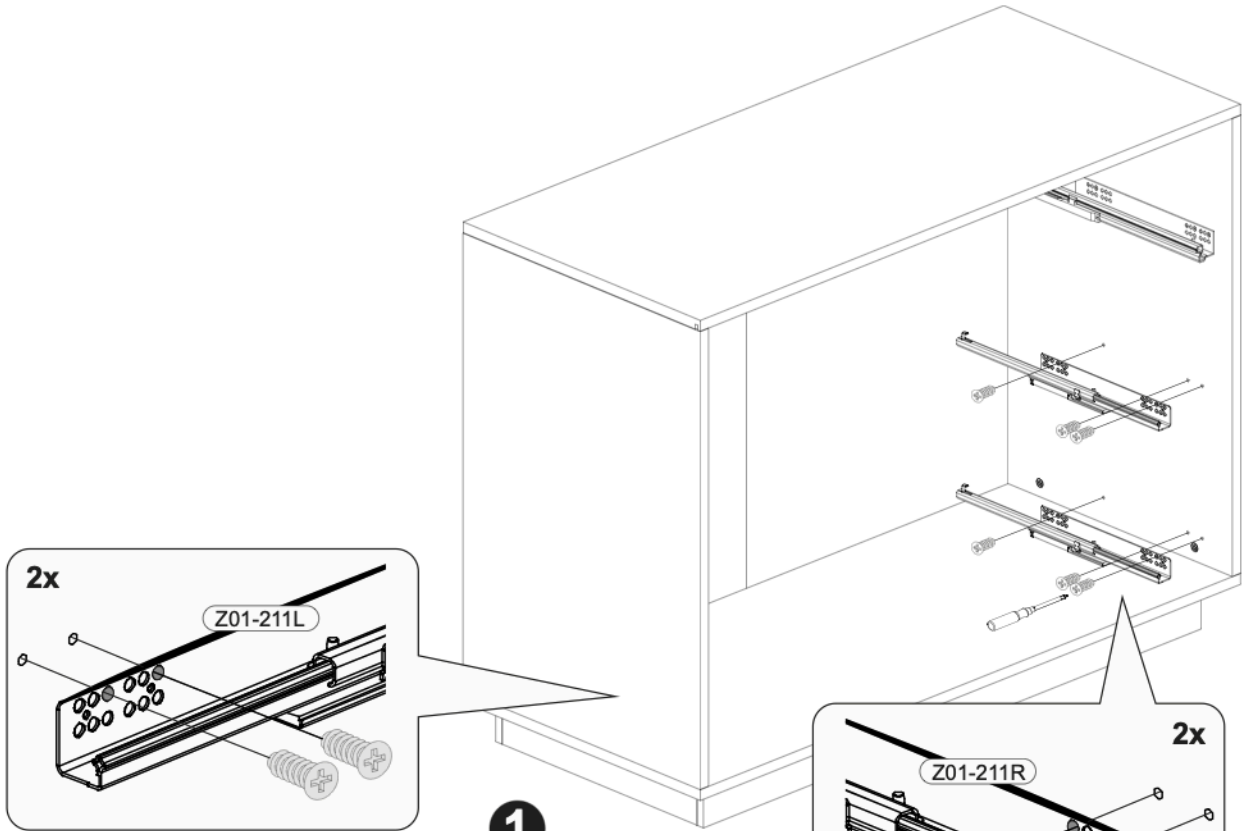



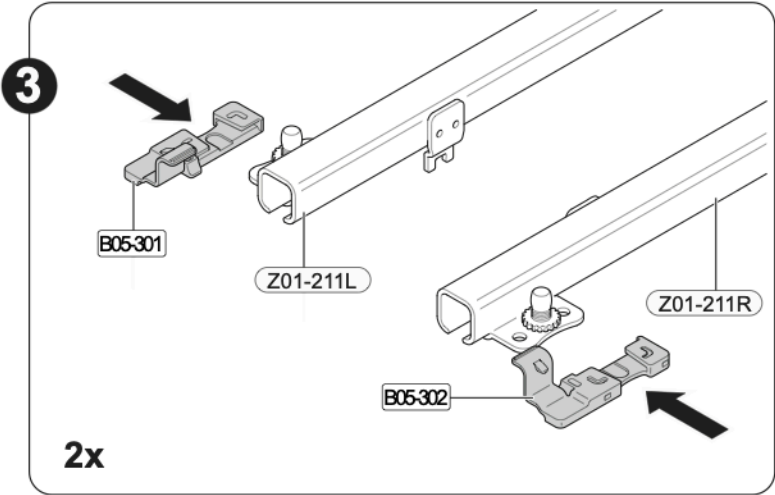

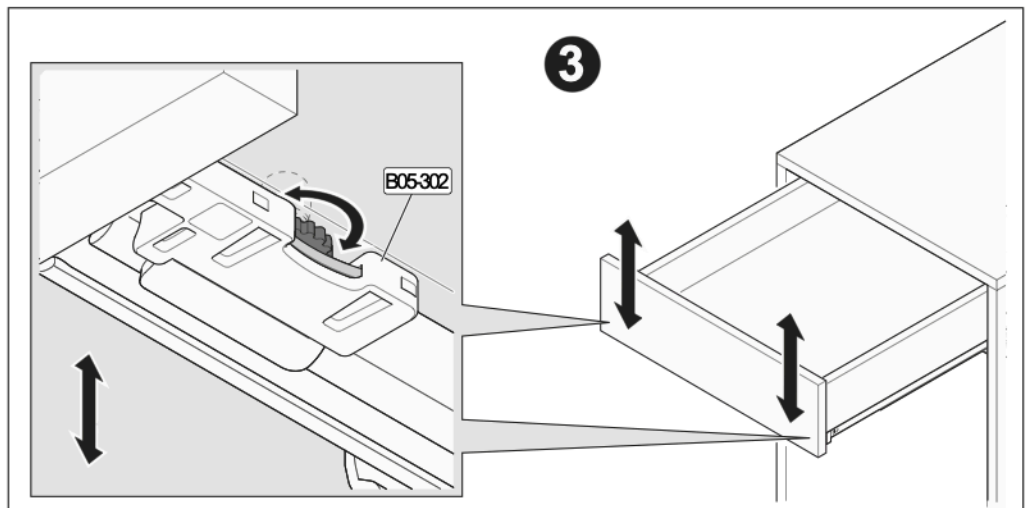
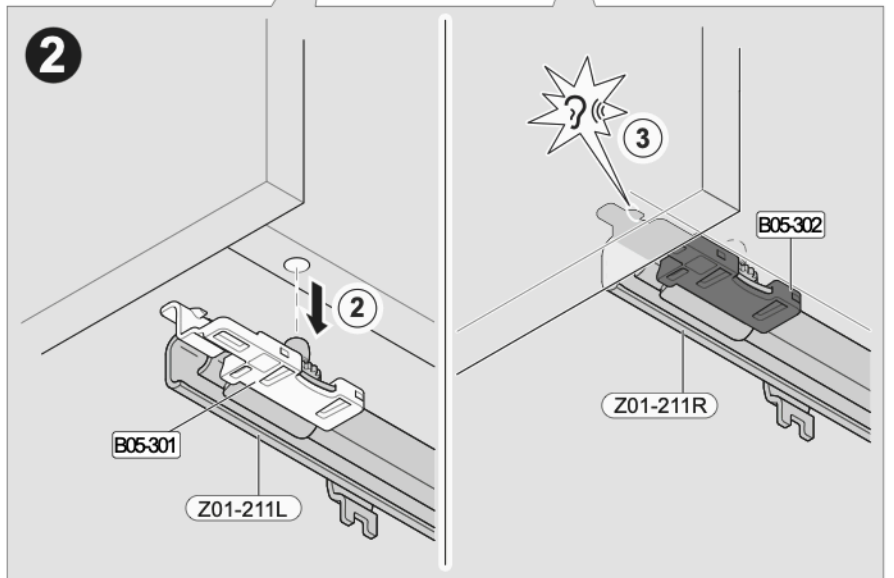
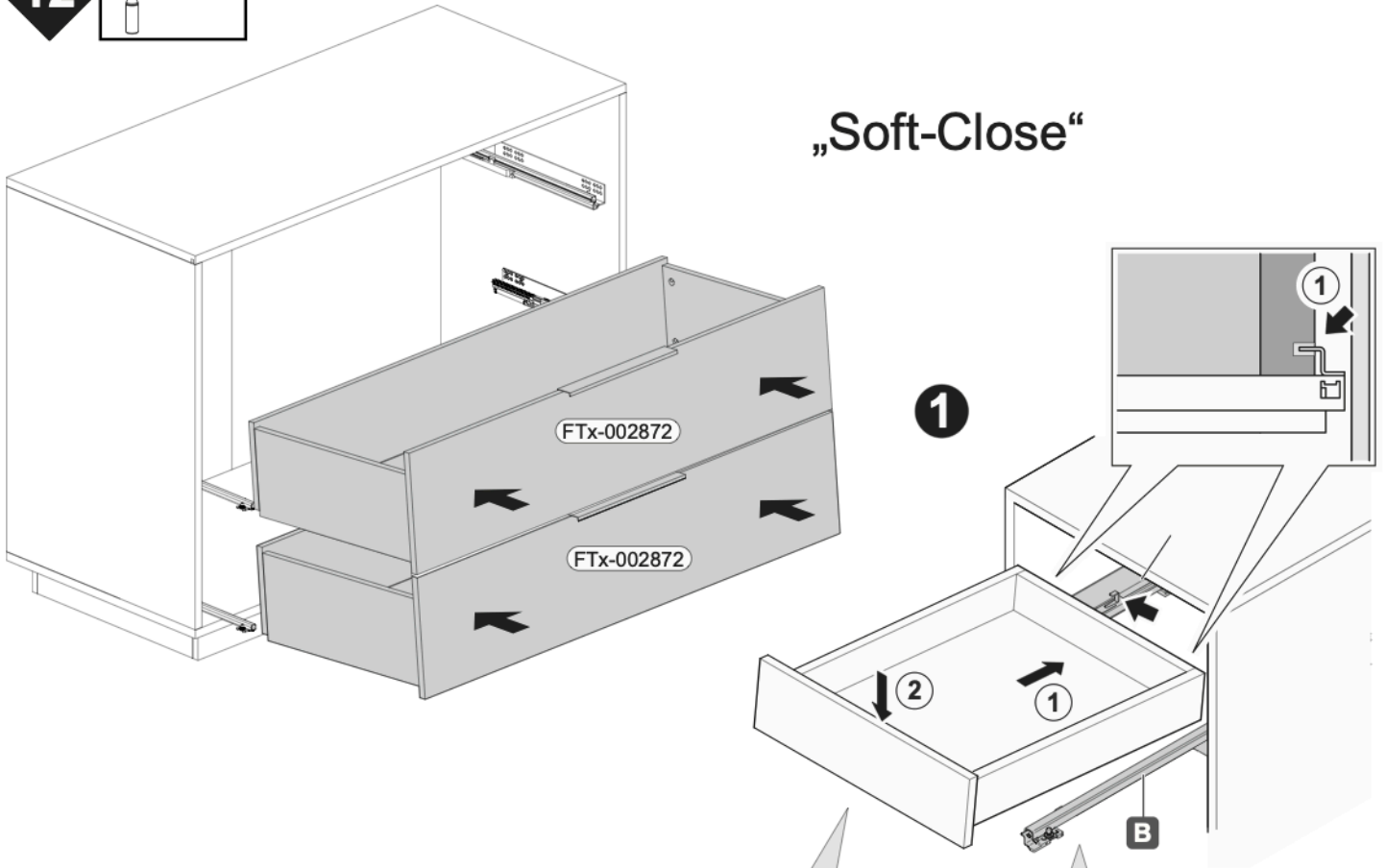

„Soft-Close“



„Soft-Close“



13

		B02-20 8x		B02-10 8x		B02-103 8x		B01-30 10x		B01-122 4x	
			ø15x12mm				8x30		3x16		4,0x13

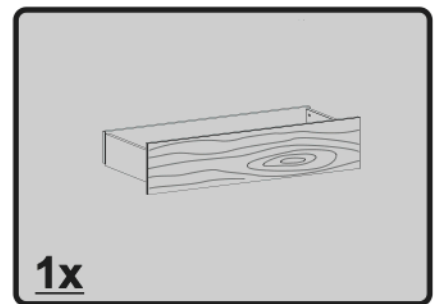
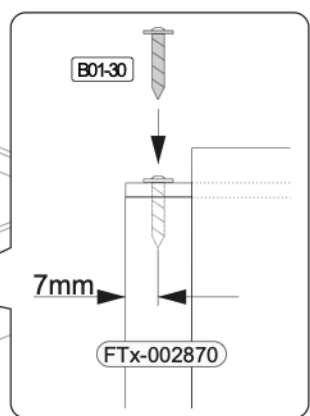
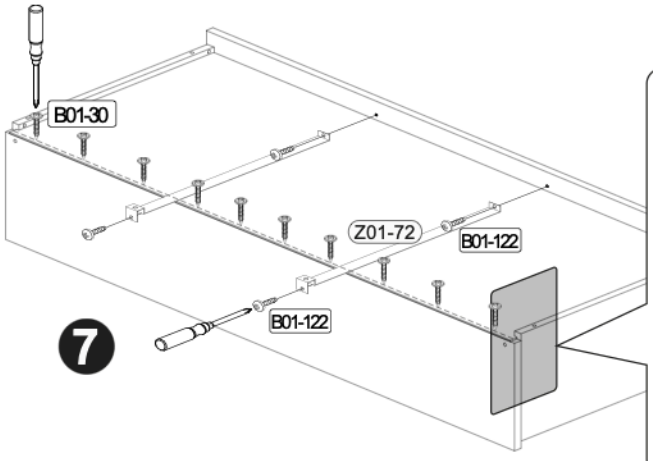
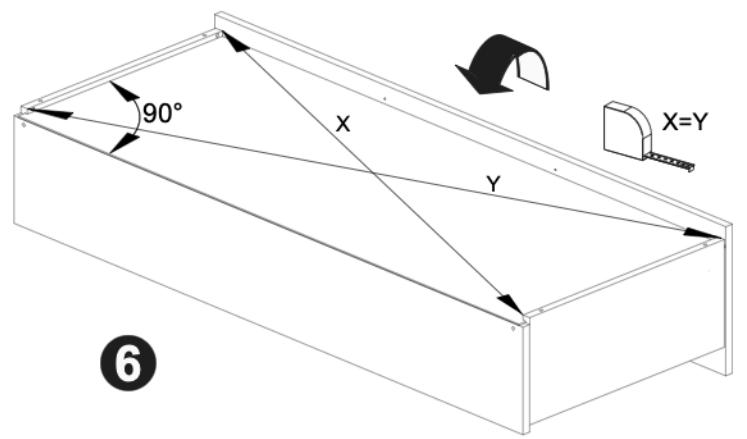
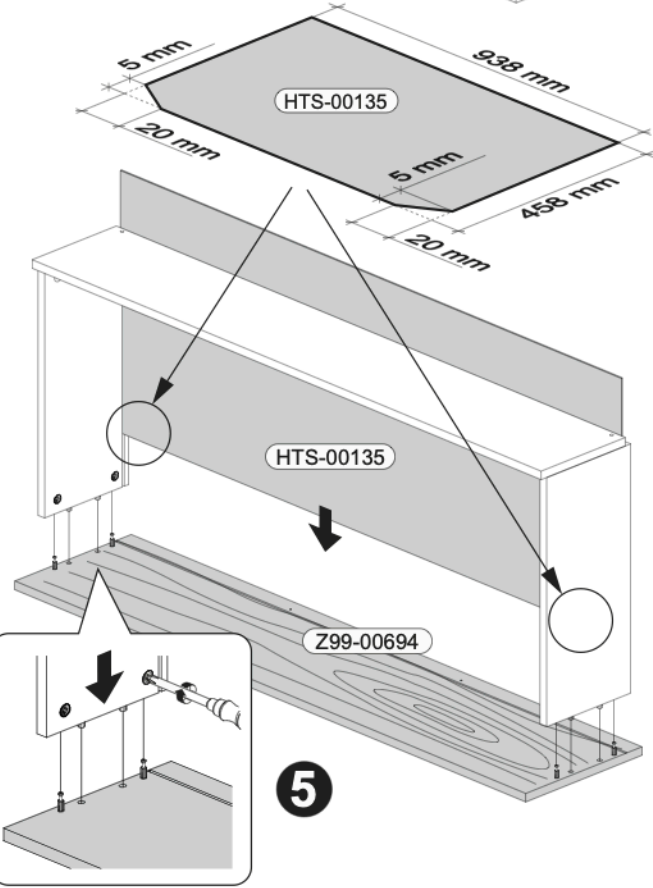
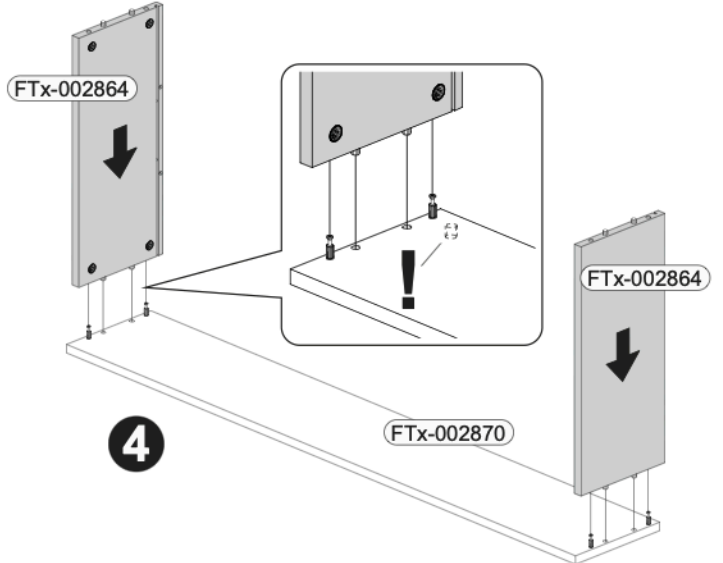
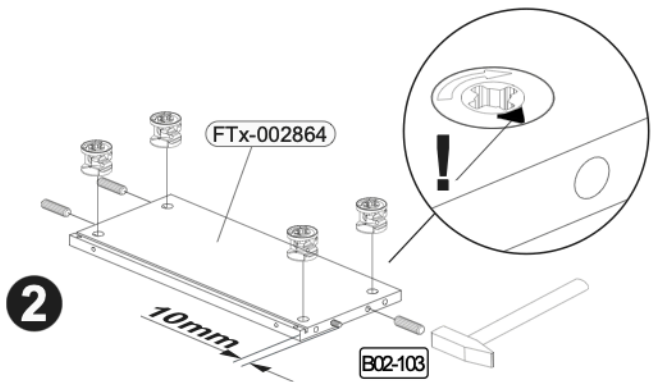
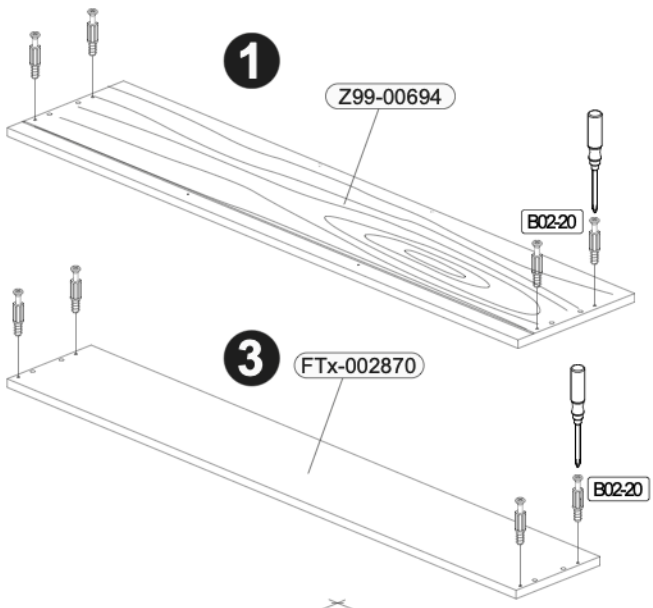

14

	B05-303	
	2x	

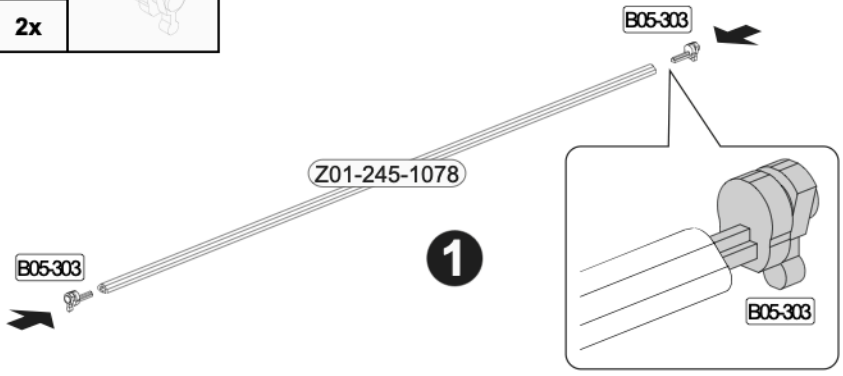

„Push-to-Open“

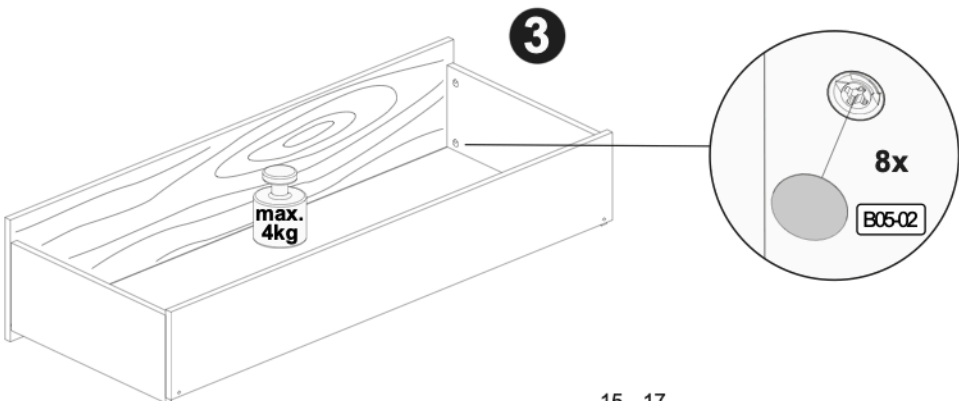
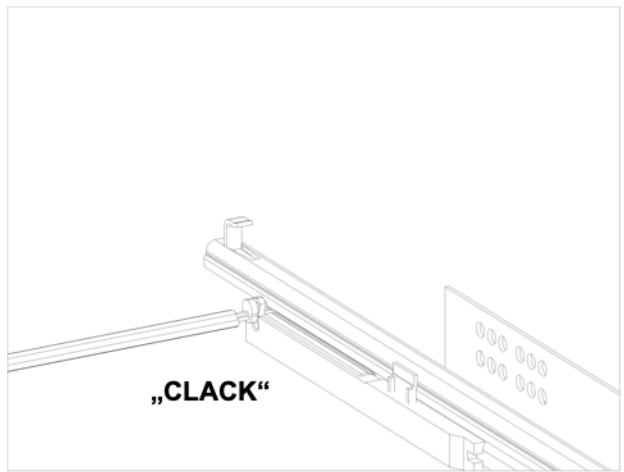
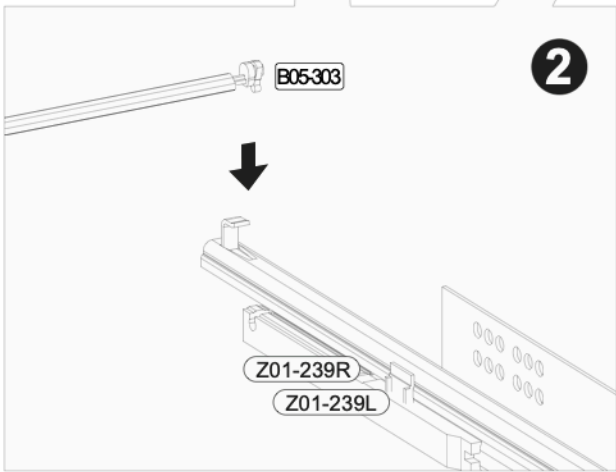
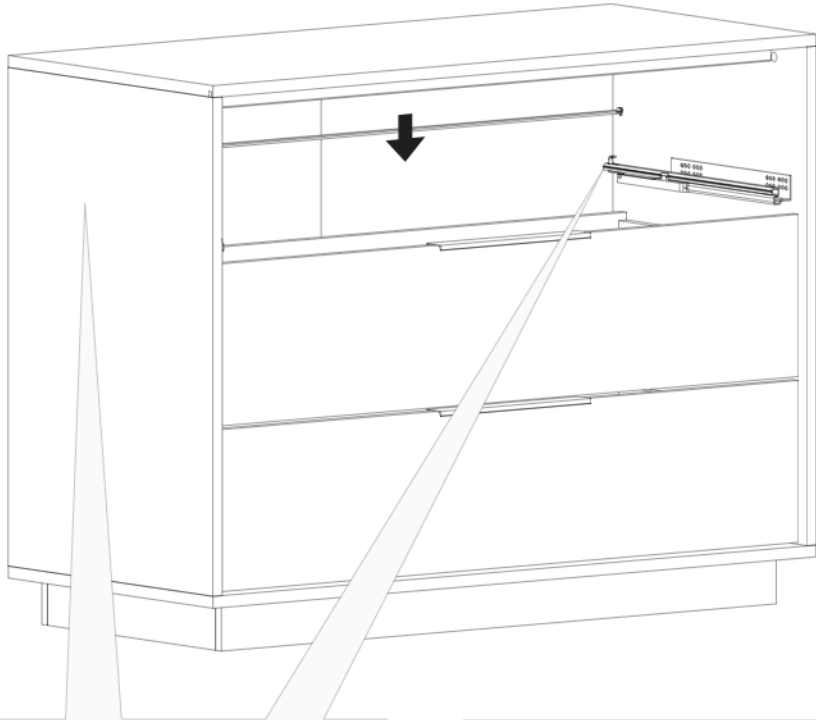

15

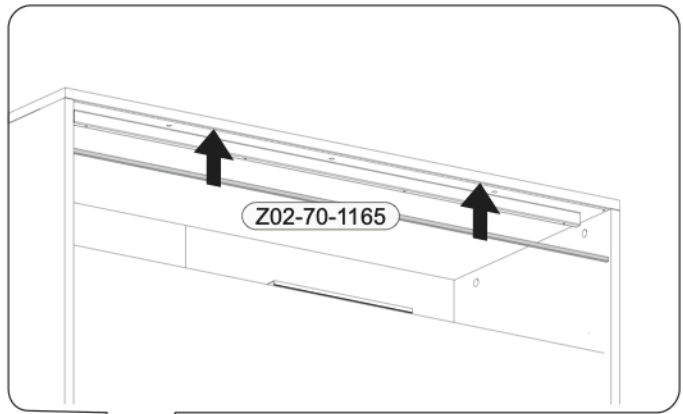
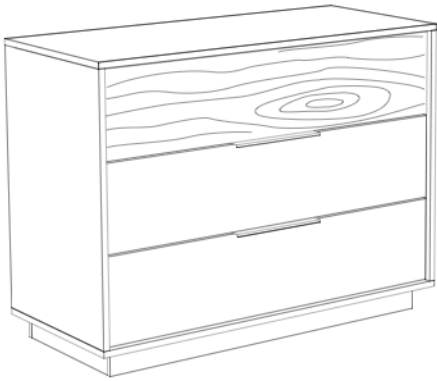
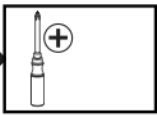

↑ ~~„LED“~~



↓ „LED“

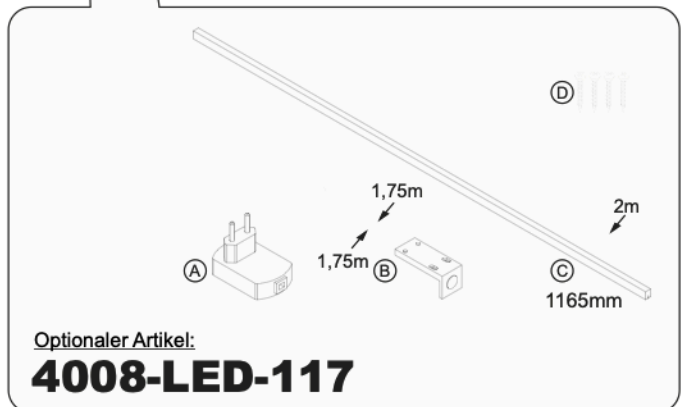
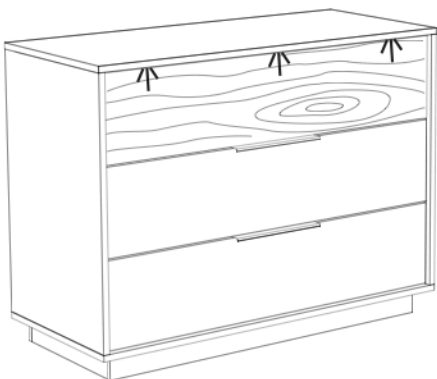

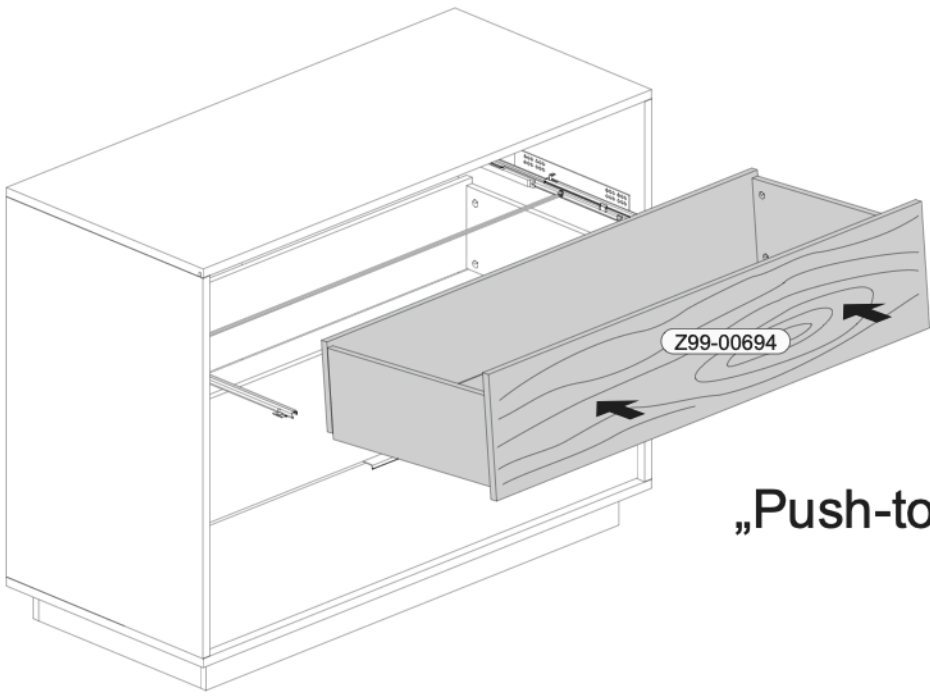

„Push-to-Open“

