

Artikel.-Nr.:

**6020-SB-23**

Montageanleitung.-Nr.:

**MA1-00786**





SCAN ME

Das Ersatzteil-Anforderungsformular finden Sie auf  
The replacement parts requisition form you find on  
<https://www.mausbacher.de/ersatzteile/>

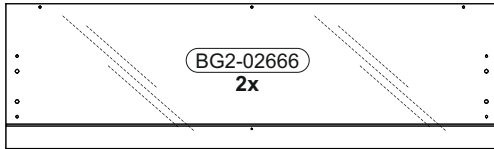
## Colli 1/3

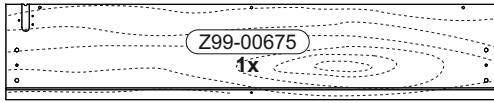

1042 x 308



1042 x 204

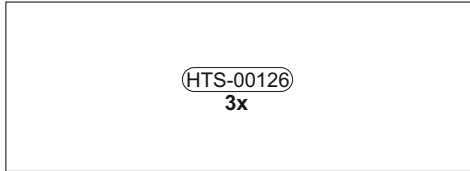

990 x 358

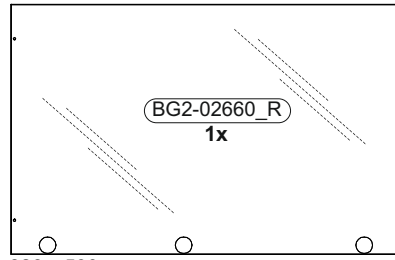

826 x 530

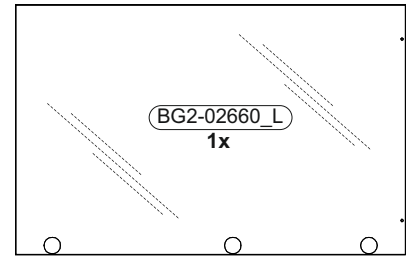

826 x 530

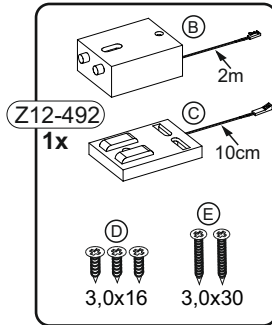
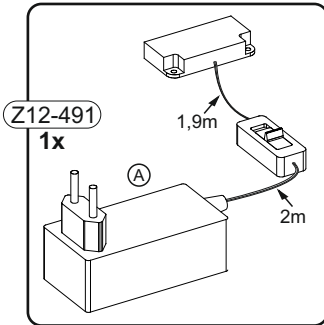
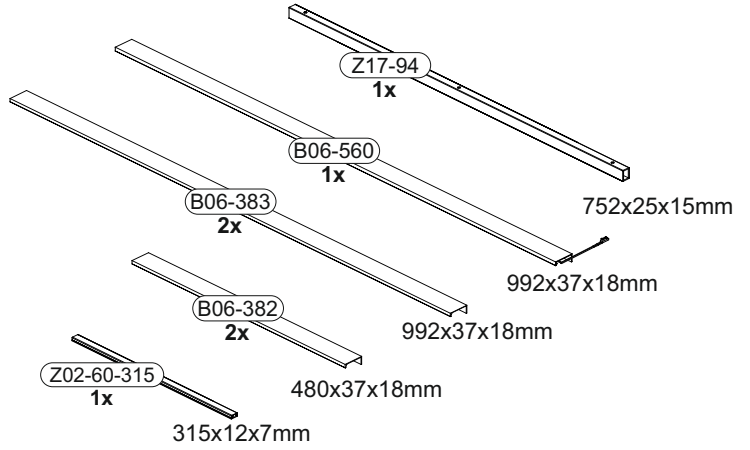

## Colli 3/3

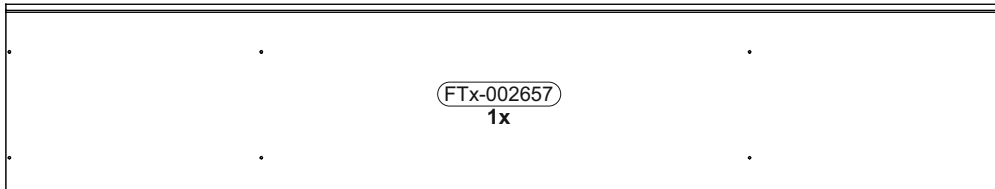

2114 x 394

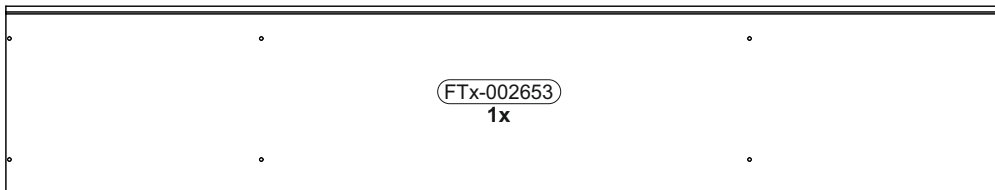

2114 x 394

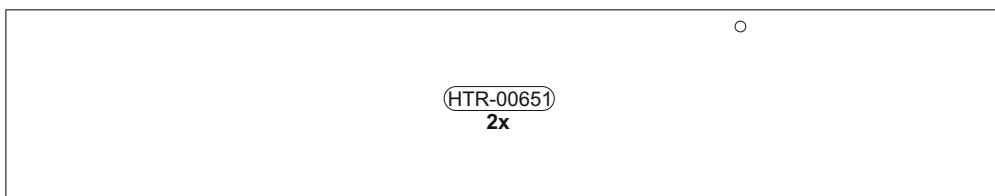

2096 x 406

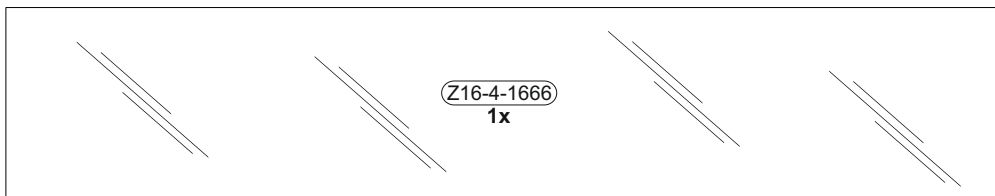

2136 x 415

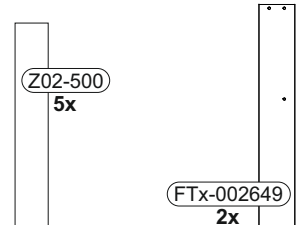

500 x 50

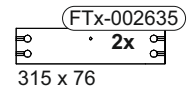

315 x 76

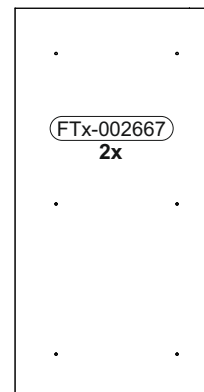









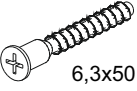



830 x 413

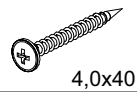

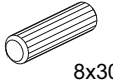

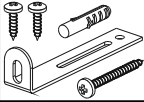
2038 x 76



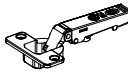

**BT1-00872**

B01-10 8x  6,3x50	B01-122 6x  4,0x13	B01-190 12x  M4x20
B01-200 35x  6,3x13	B01-30 46x  3x16	B01-347 12x  5x8
B01-36 3x  4,0x40	B01-80 32x  3,5x13	B01-90 4x  3,5x20
B02-103 24x  8x30	B02-160 8x 	B02-169 12x  $\varnothing$ 12mm
B08-80 1x 	B02-10 28x  $\varnothing$ 15x12mm	B02-20 28x 

**BT1-00027**

B03-01 6x 	B03-05 6x 
--	---

**BT1-00871**

B02-133 10x 	B03-130 10x 
B05-02 12x  $\varnothing$ 20mm	B05-185 4x 
B03-134 15x 	

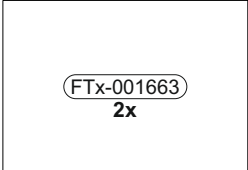
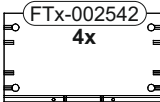
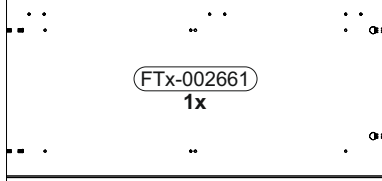
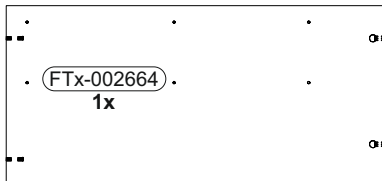
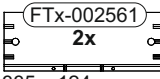
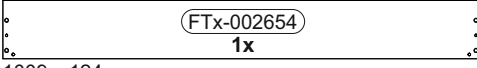
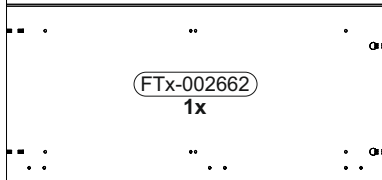
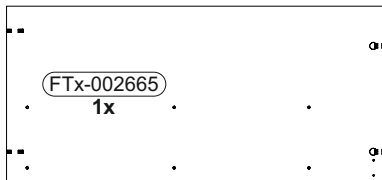
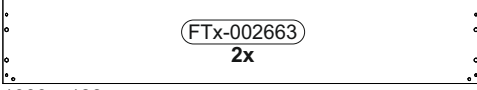
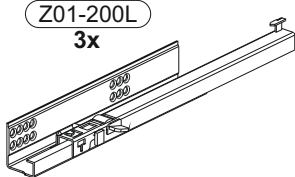
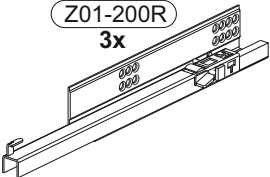
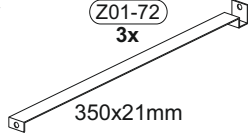
 FTx-001663 2x 518 x 365	 FTx-002542 4x 335 x 188	 FTx-002661 1x 800 x 394	 FTx-002664 1x 800 x 377
 FTx-002654 1x 1009 x 124	 FTx-002561 2x 335 x 124	 FTx-002662 1x 800 x 394	 FTx-002665 1x 800 x 377
 FTx-002663 2x 1009 x 188	 Z01-200L 3x	 Z01-200R 3x	 Z01-72 3x 350x21mm

1

	B02-10		B02-160		B03-05	
	4x	ø15x12mm	4x		6x	

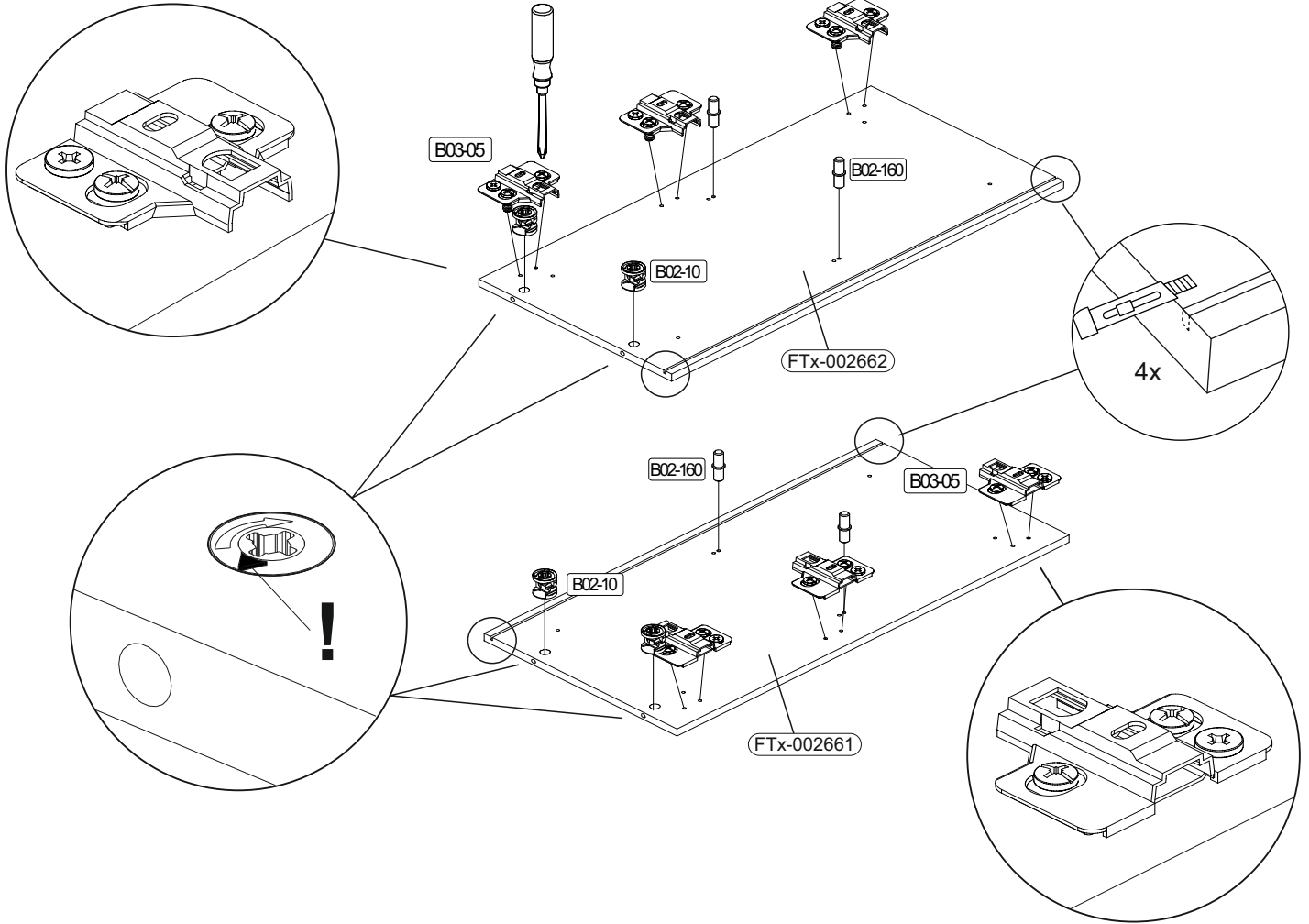

2

	B02-10		B02-160		B01-200	
	2x	ø15x12mm	2x	6x		6,3x13

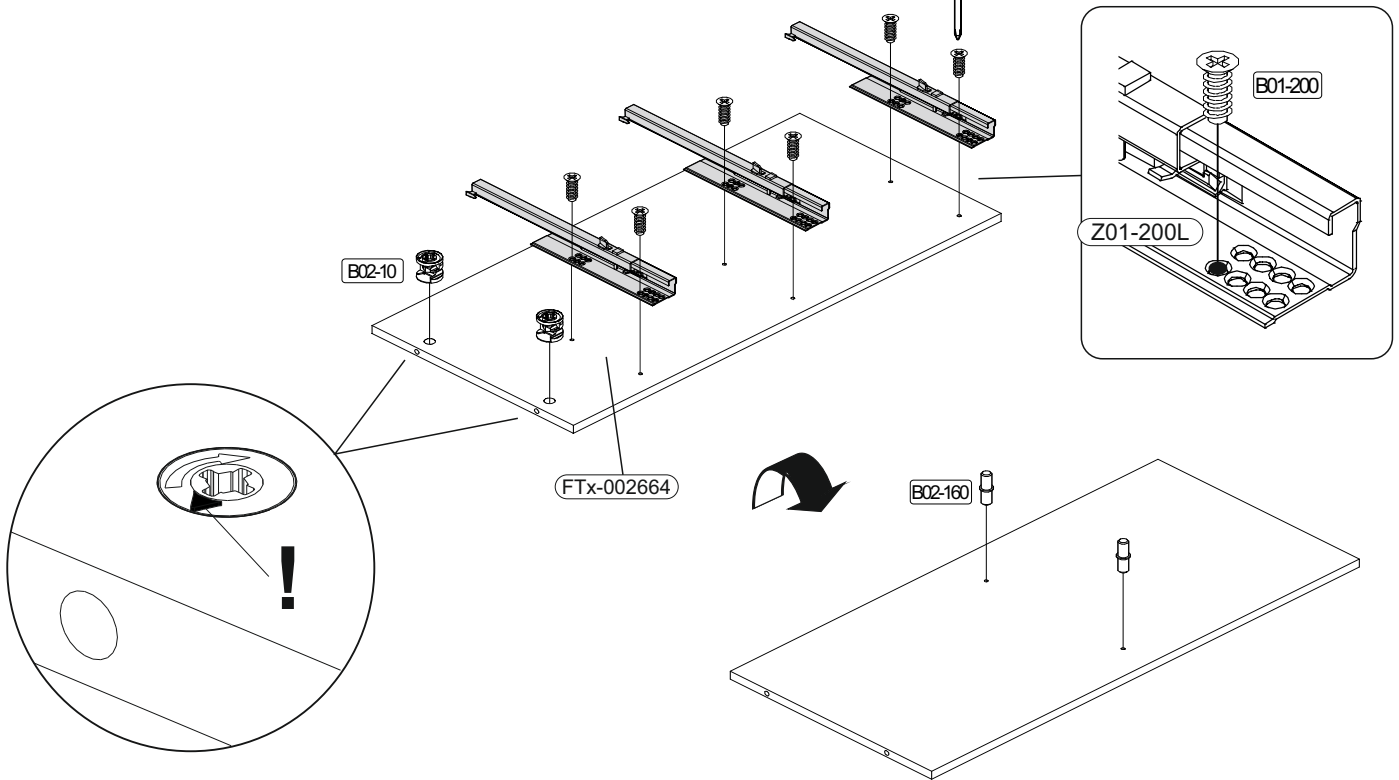

3

	B02-10		B02-160		B01-200	
	2x	ø15x12mm	2x		6x	6,3x13

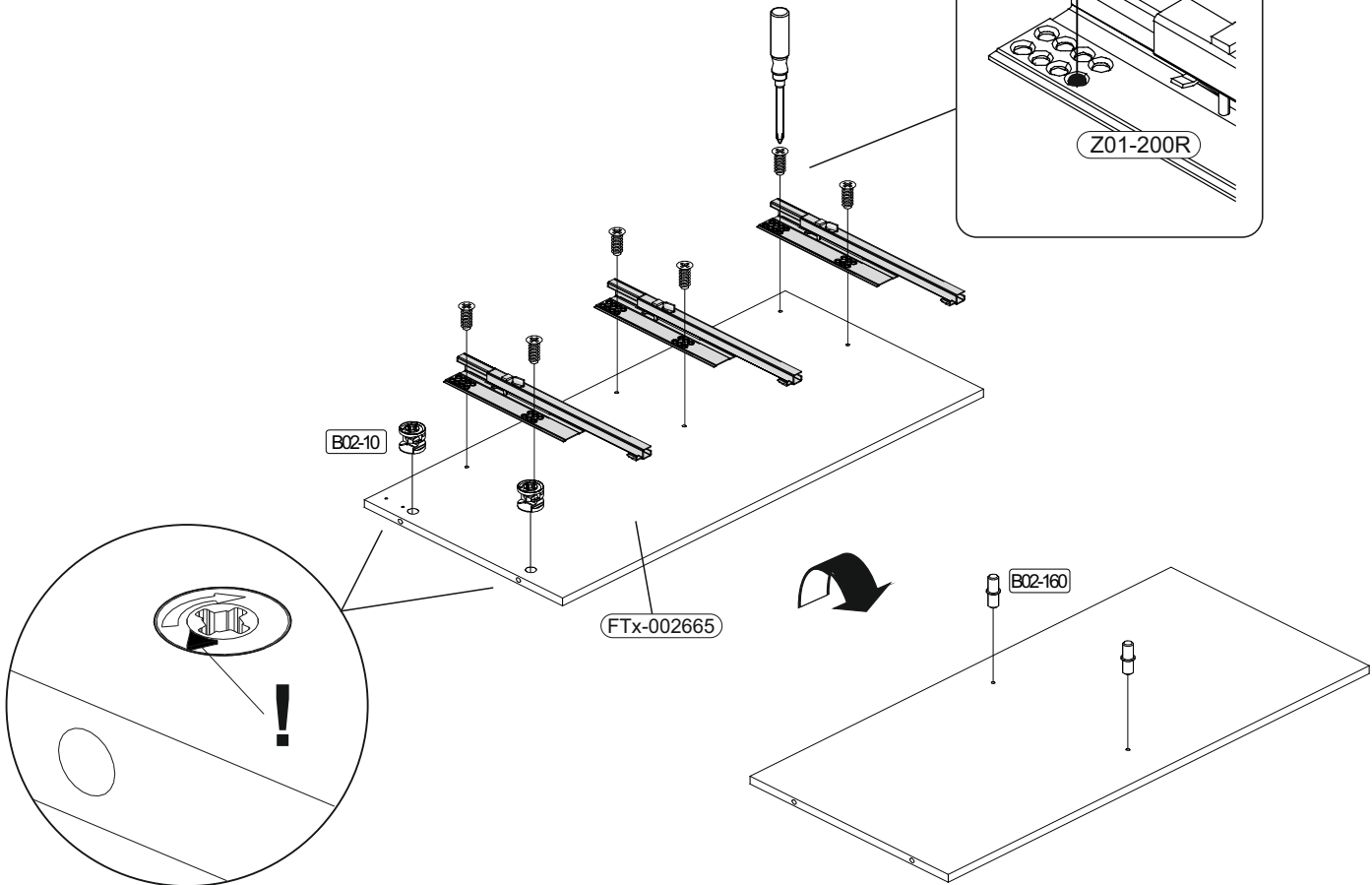
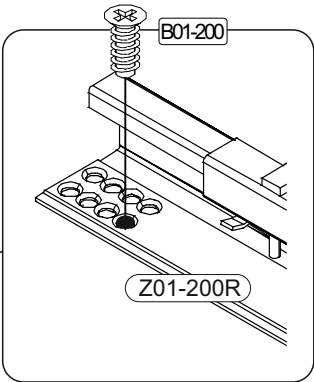

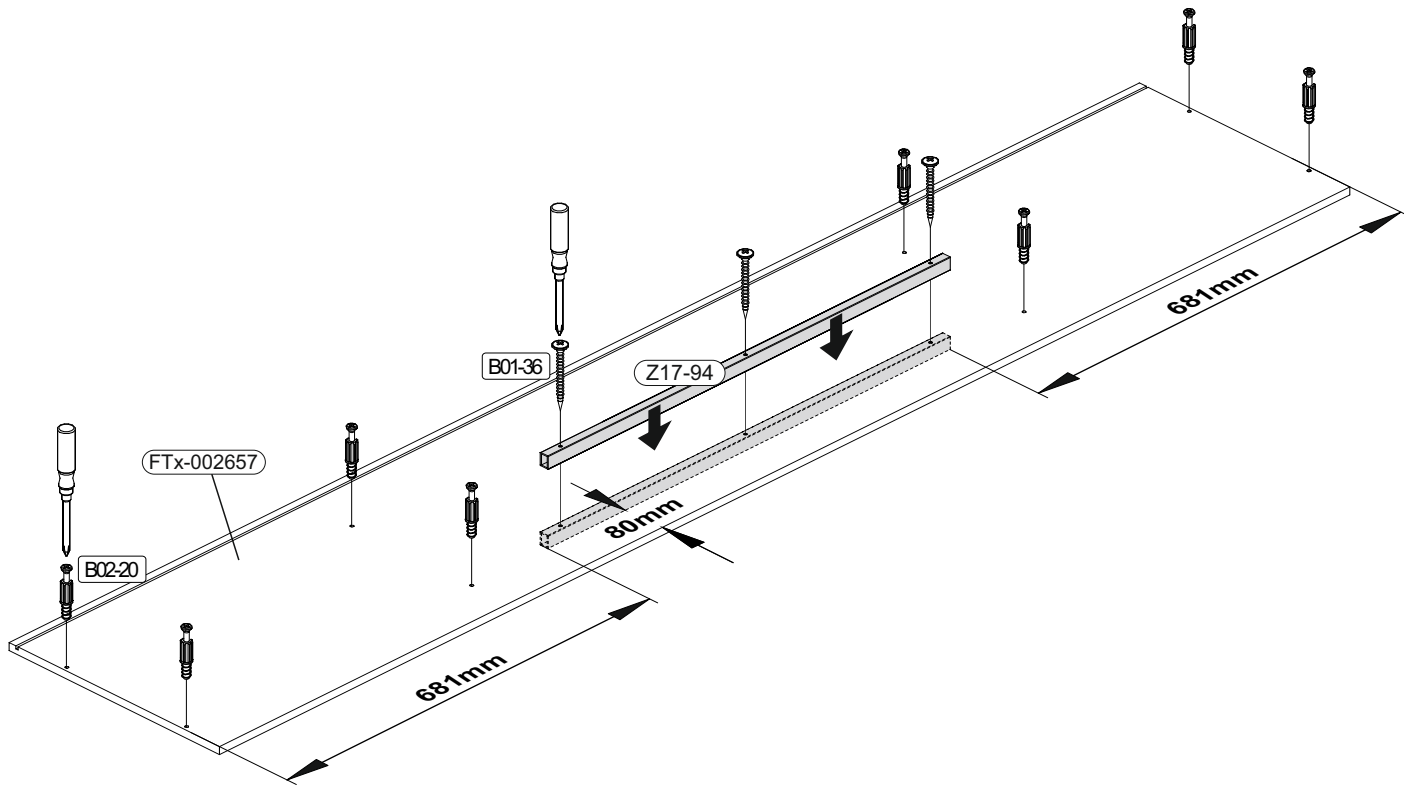

4

		B02-20		B01-36	
		8x		3x	4,0x40

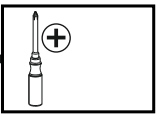

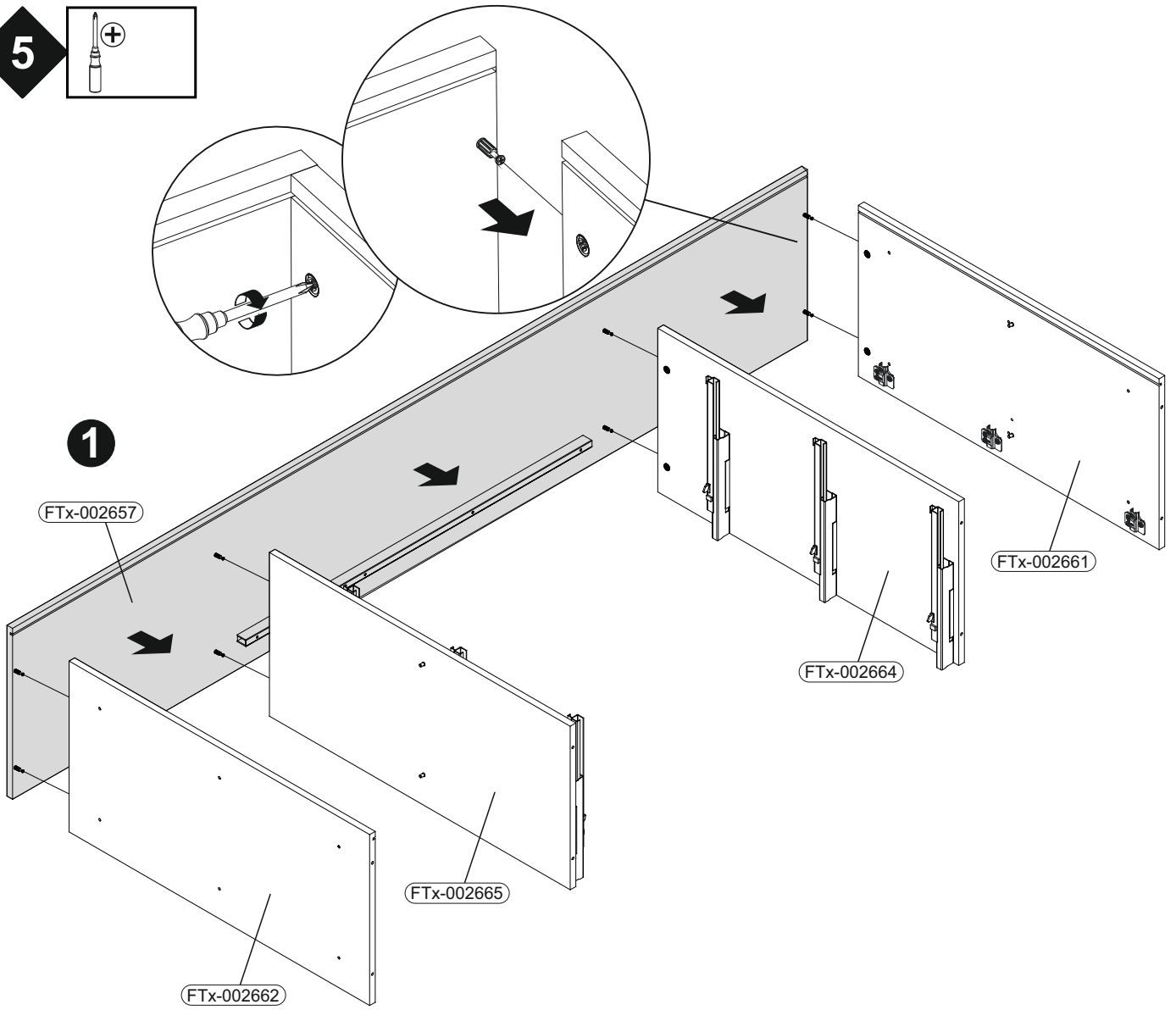
**5** 



**6** 

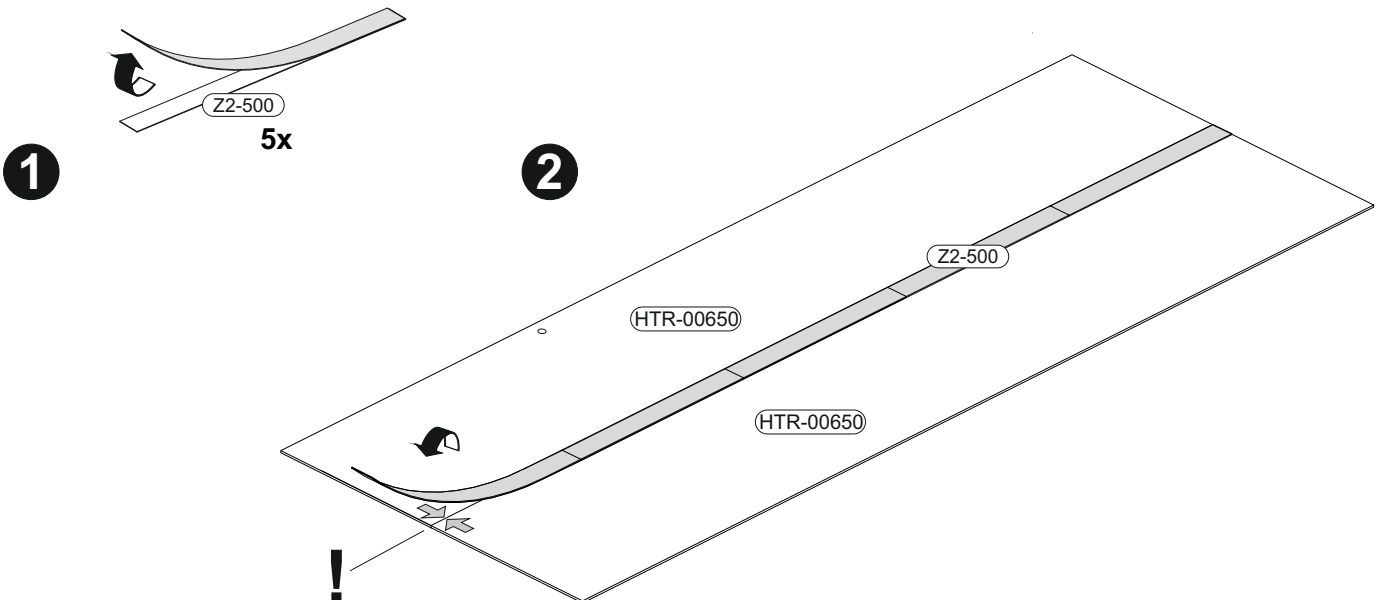

7

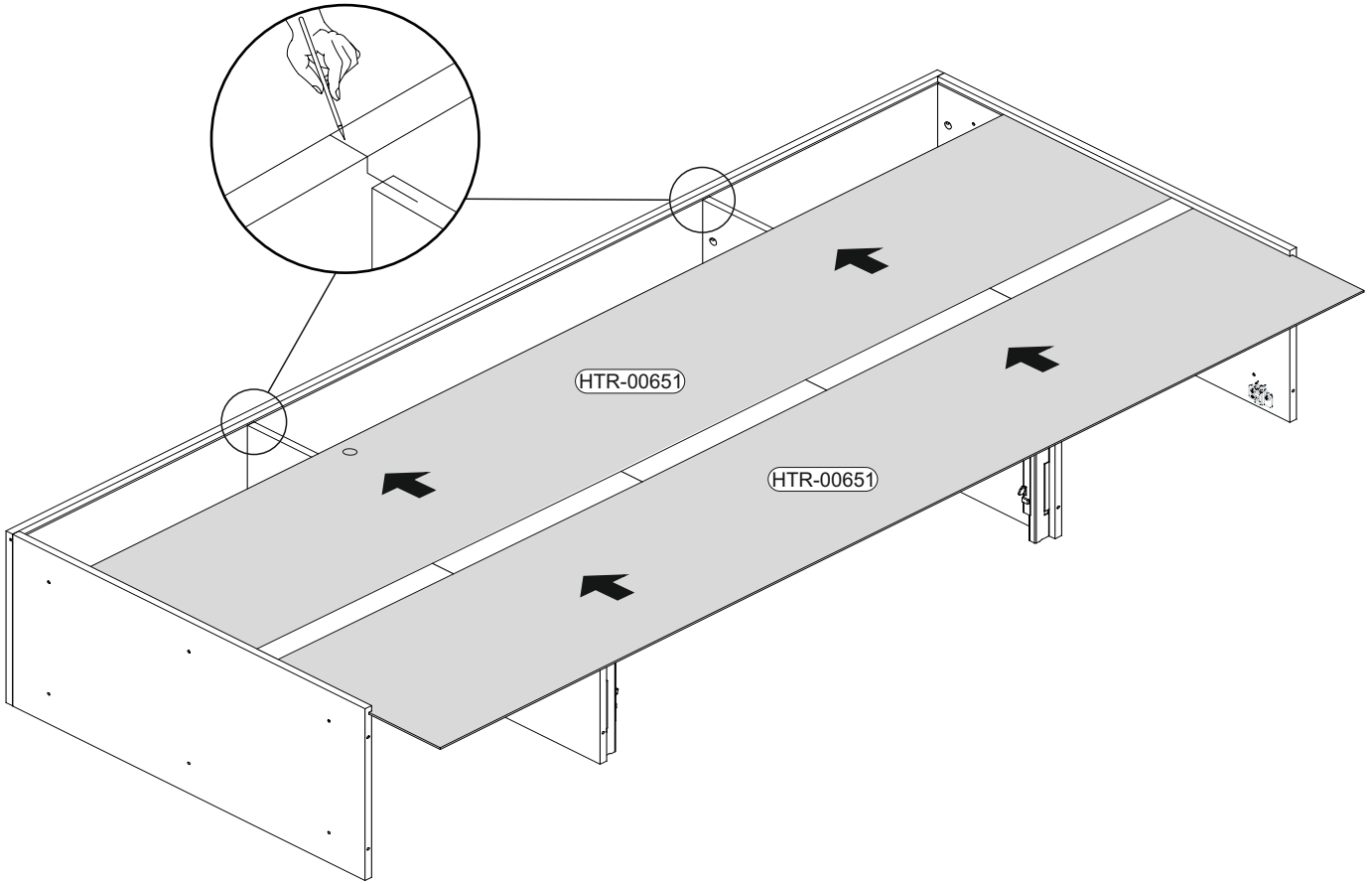
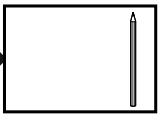

8

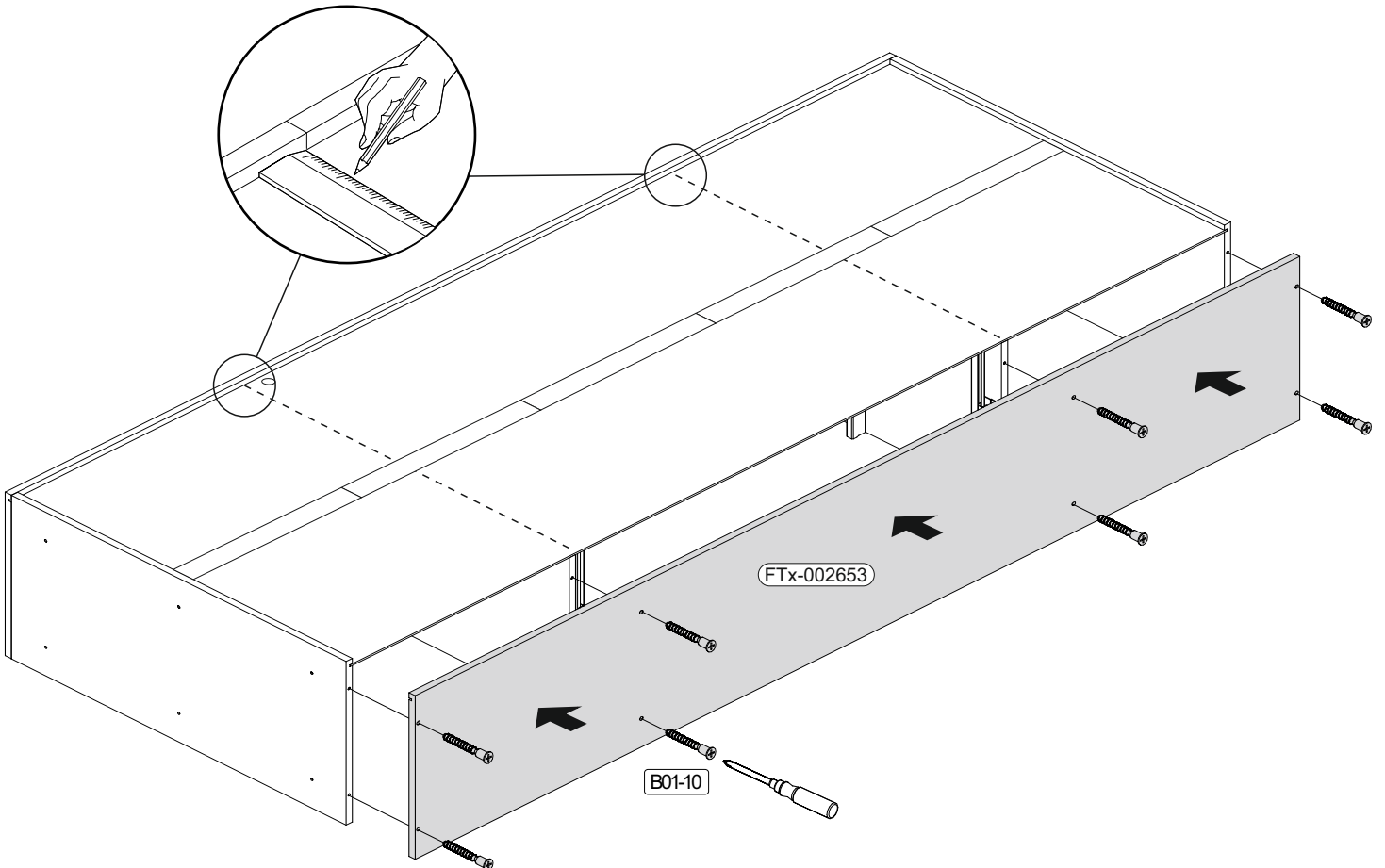
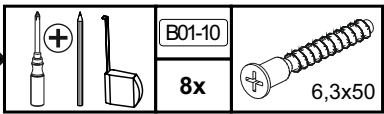

9

	B01-30	B05-185	B01-90			
	16x	3x16	4x	4x	3,5x20	

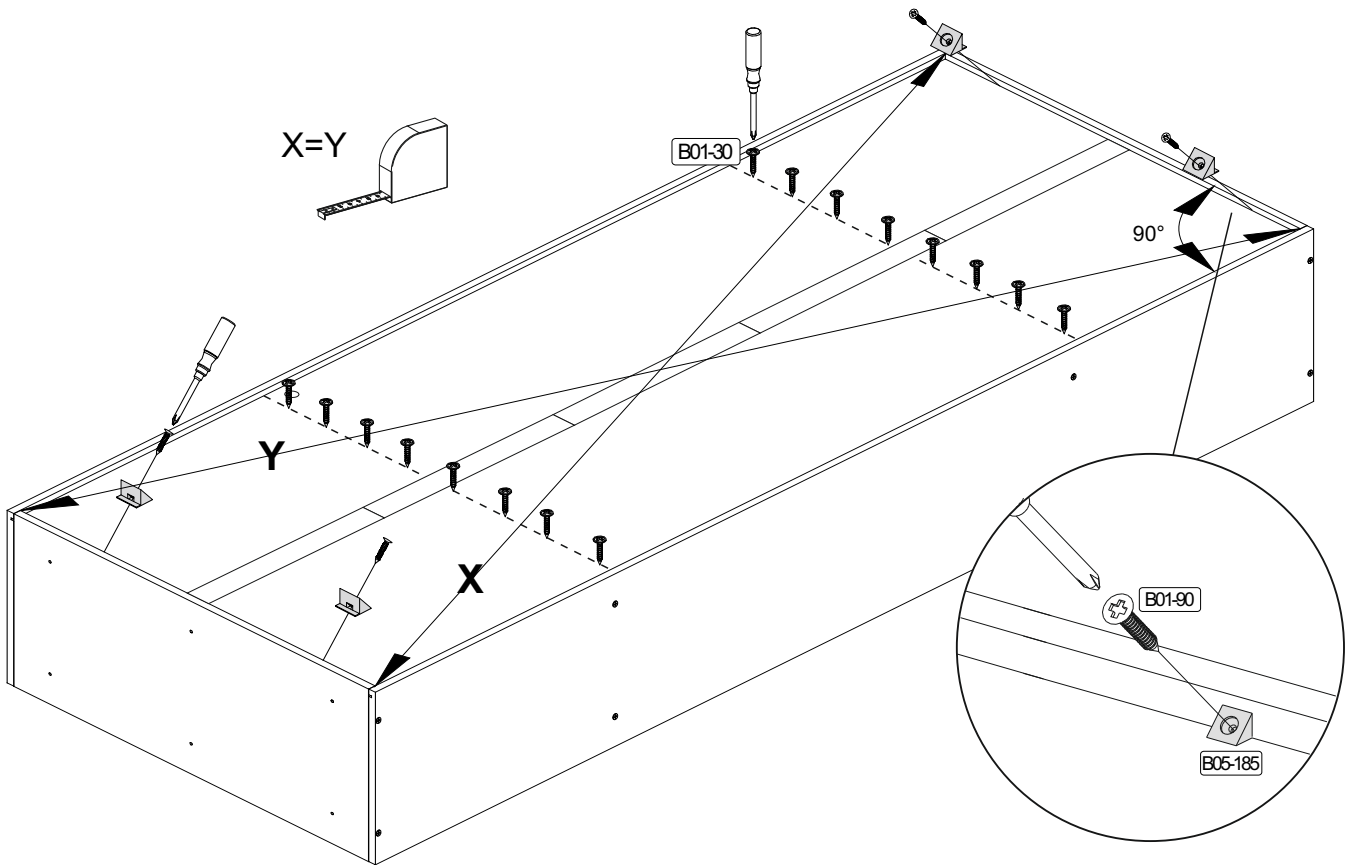

10

	B02-10	B01-200	B01-80	B02-133	B02-20			
	8x	ø15x12mm	10x	6,3x13	10x	3,5x13	10x	8x

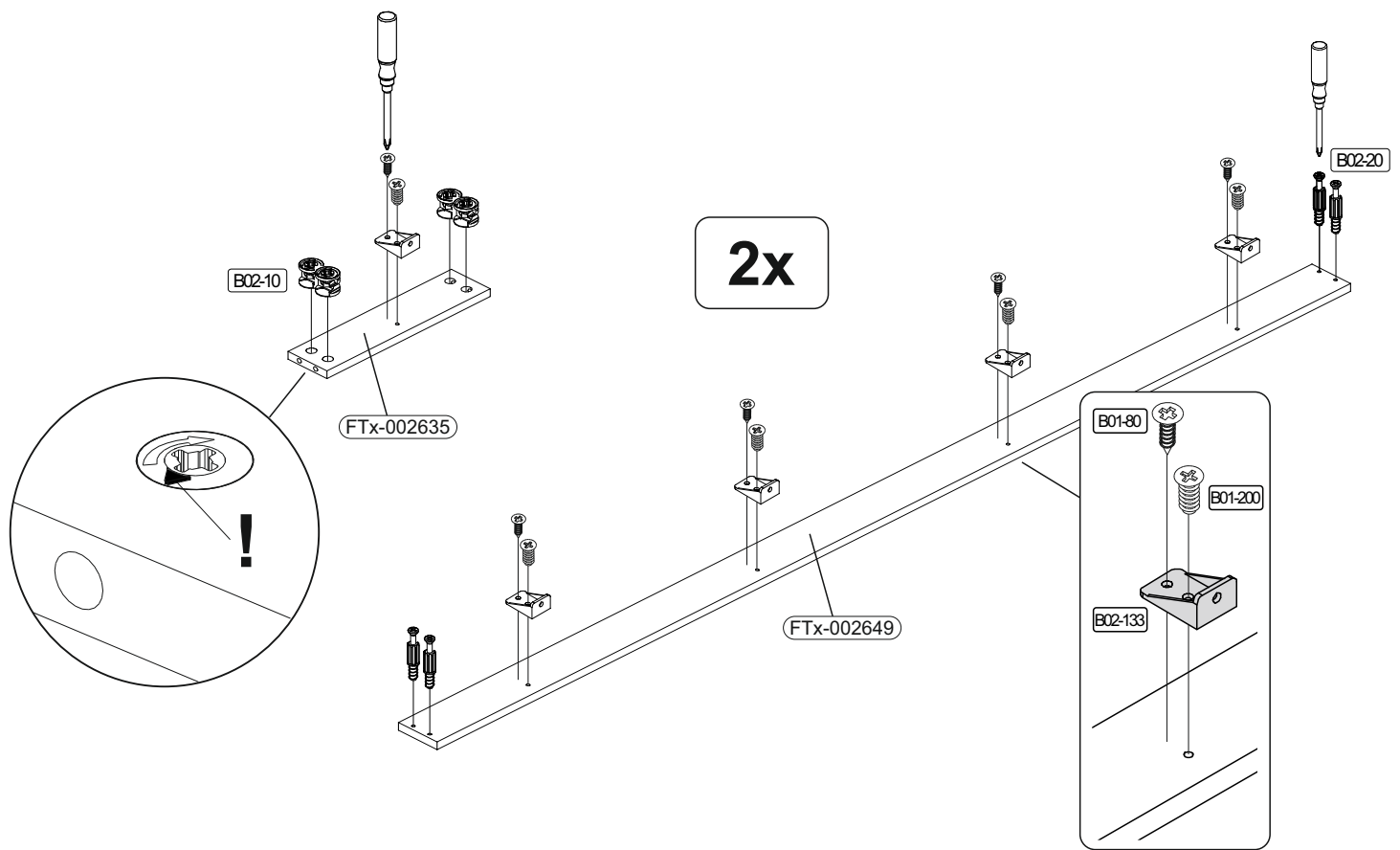

11

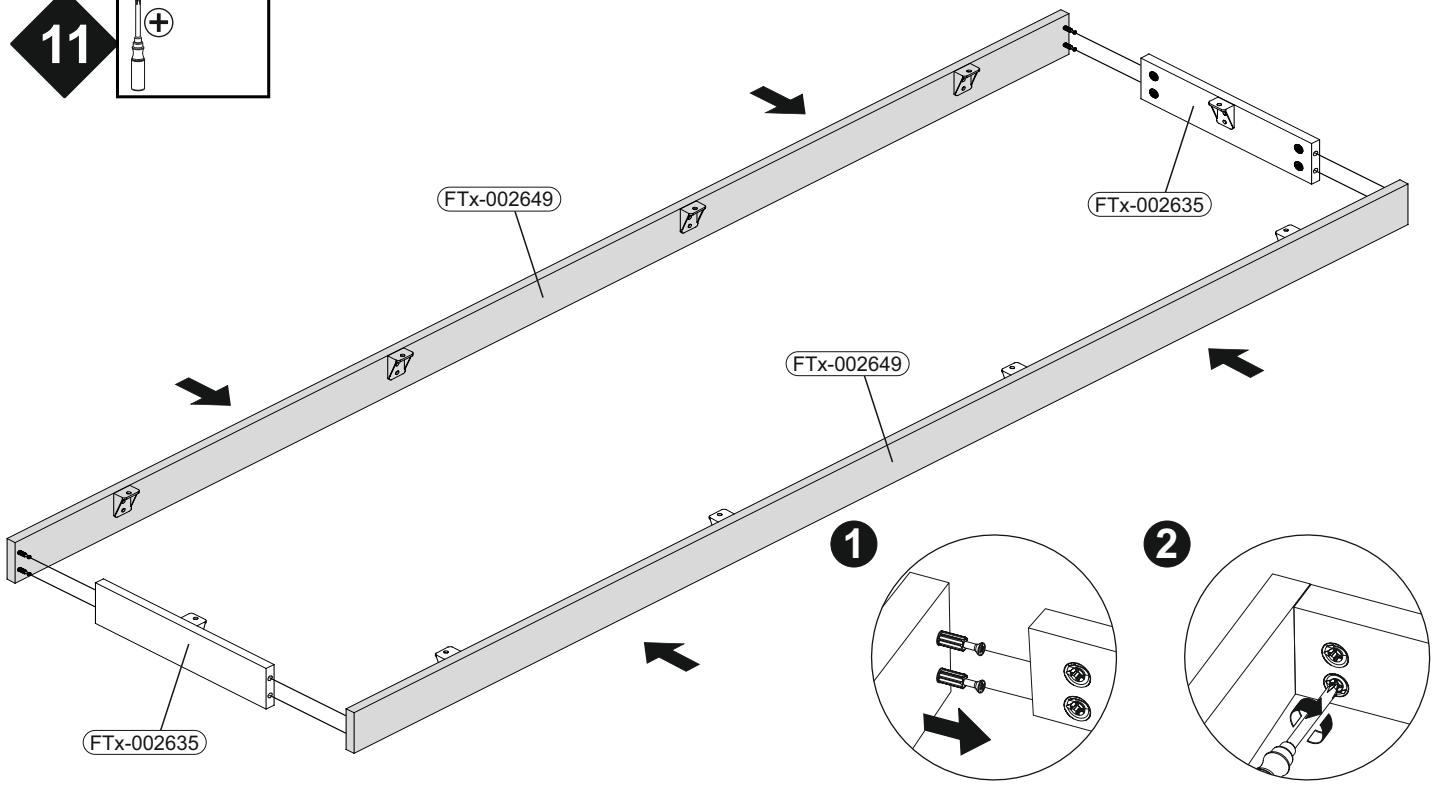
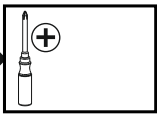

12

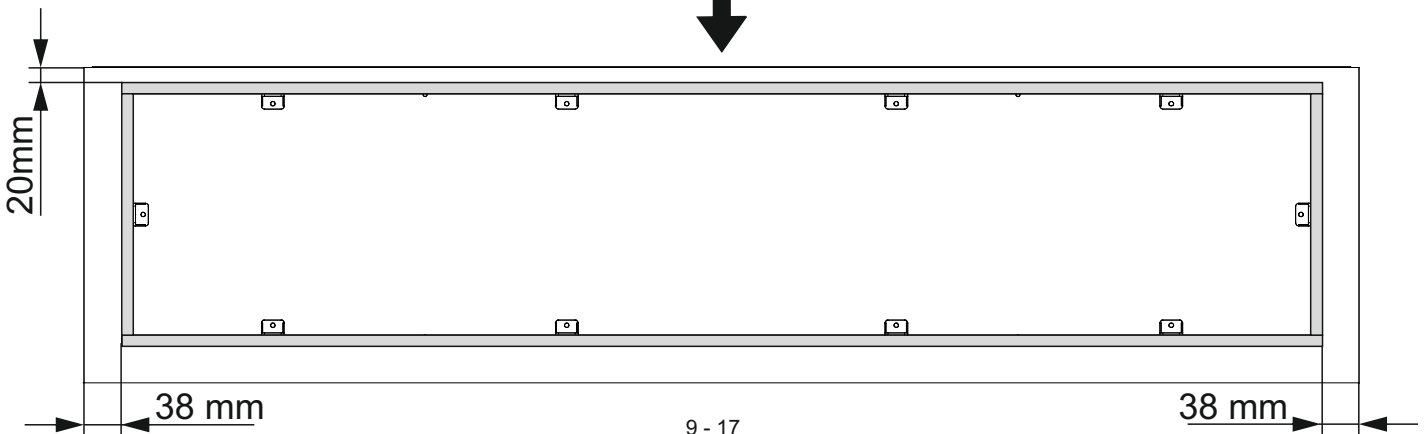
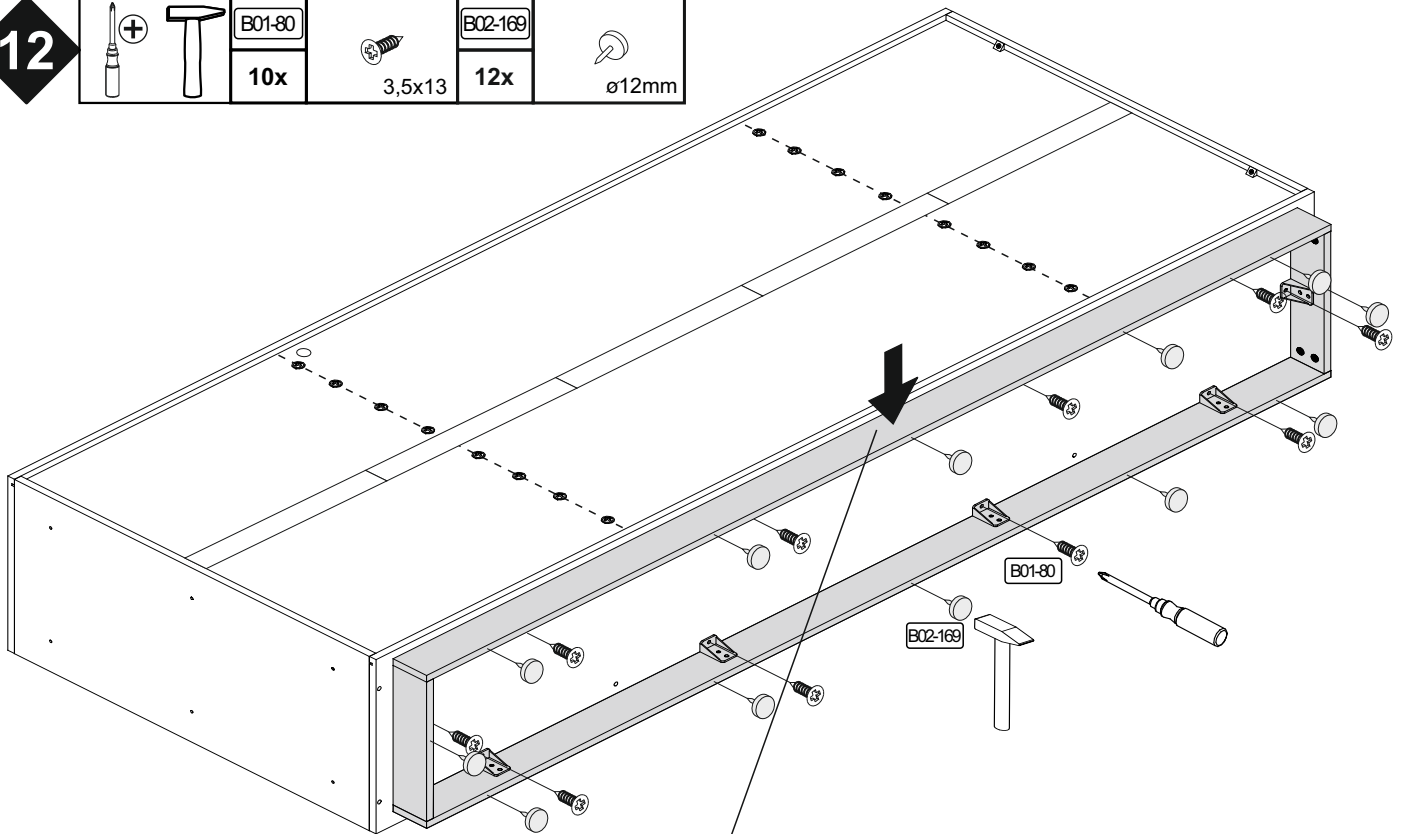
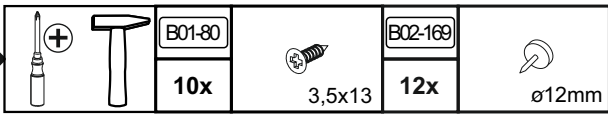

13

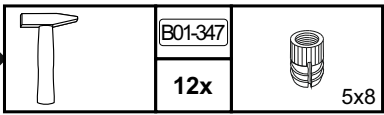

2x

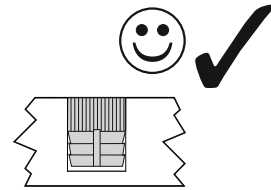
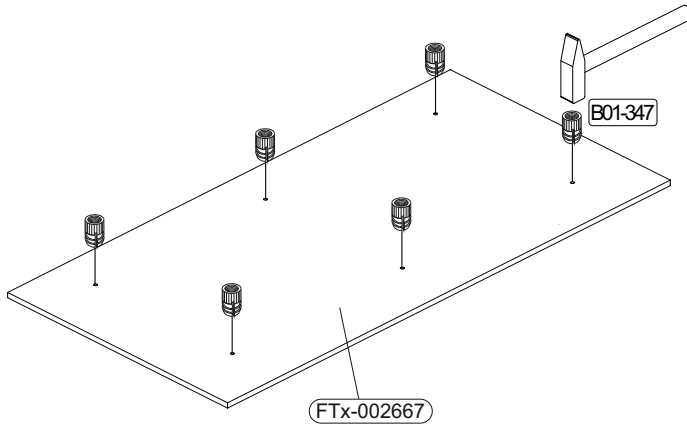

14

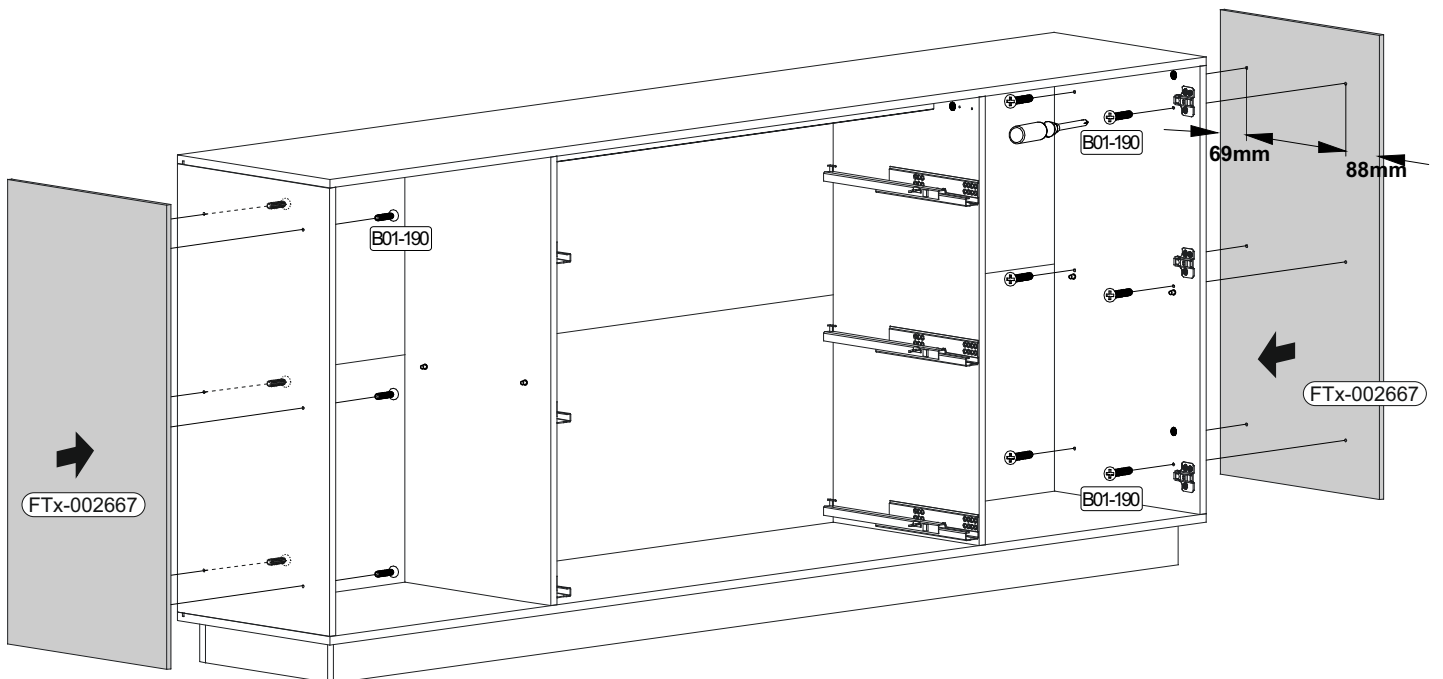
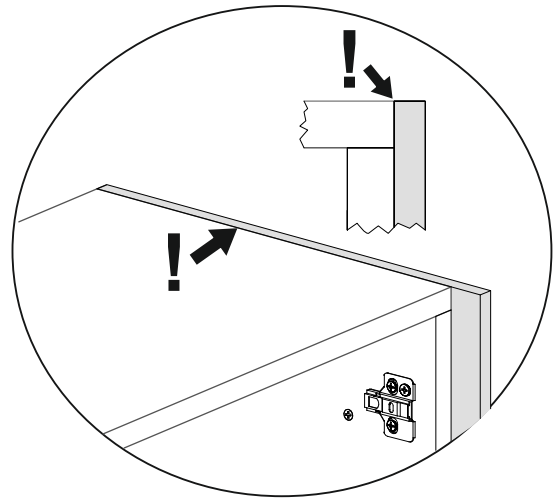
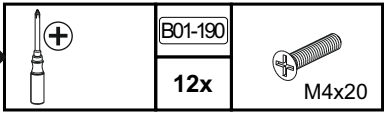





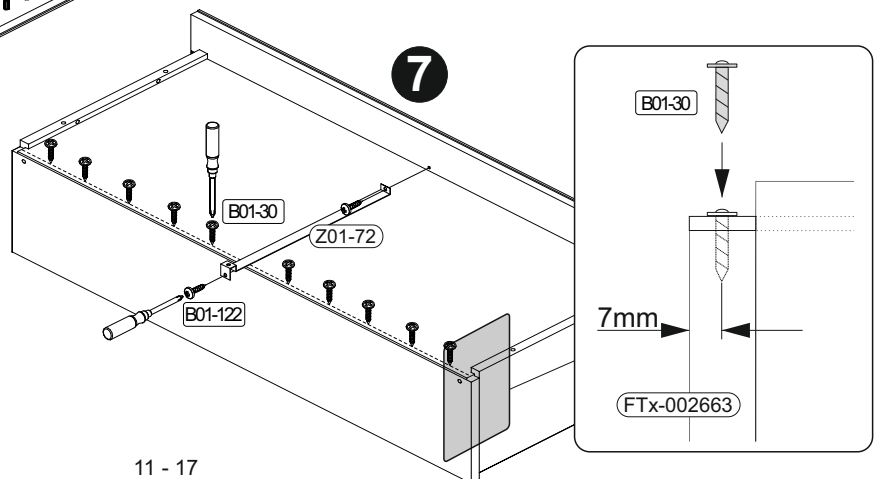
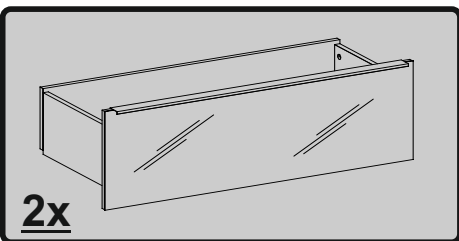
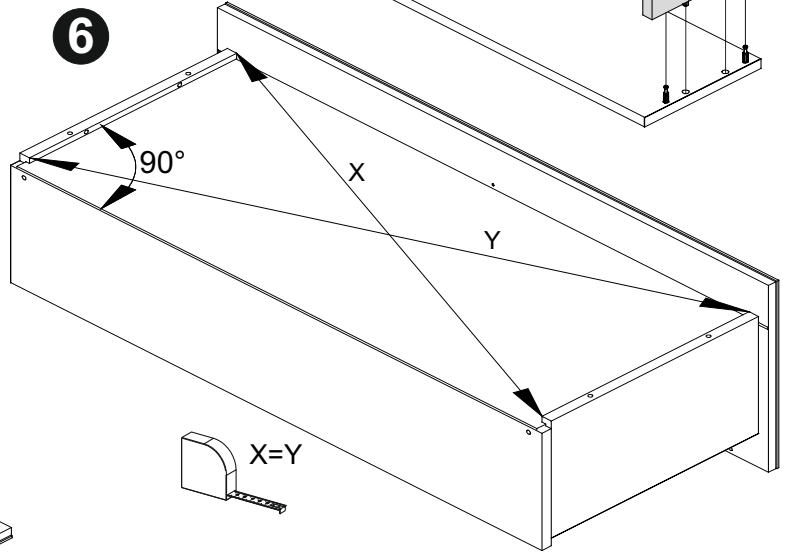
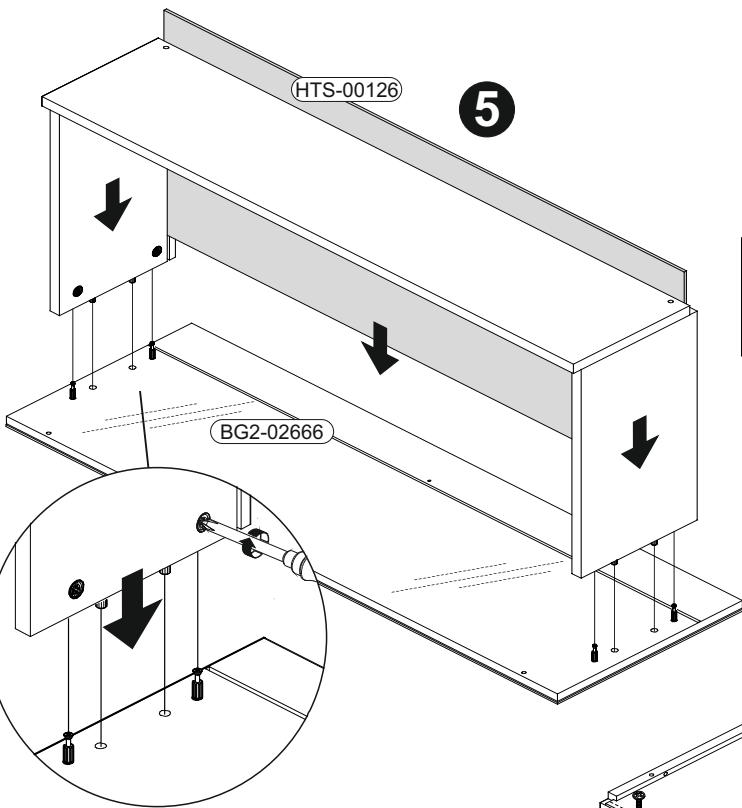
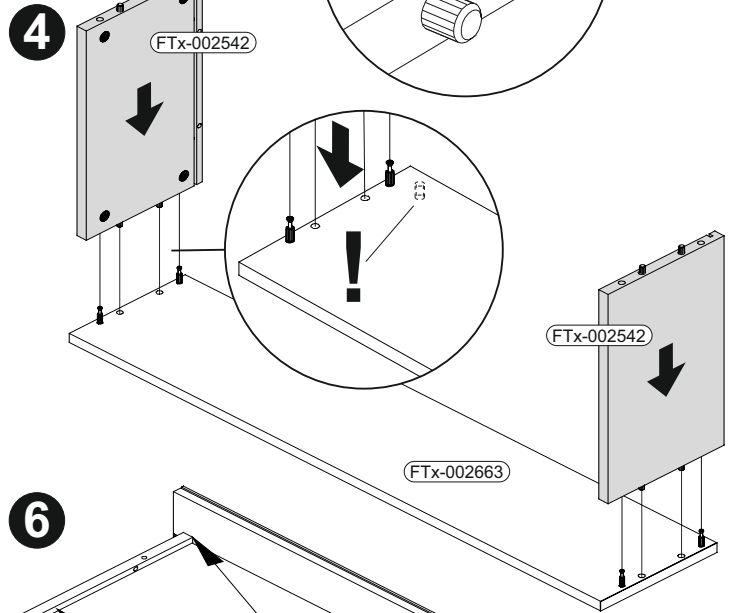
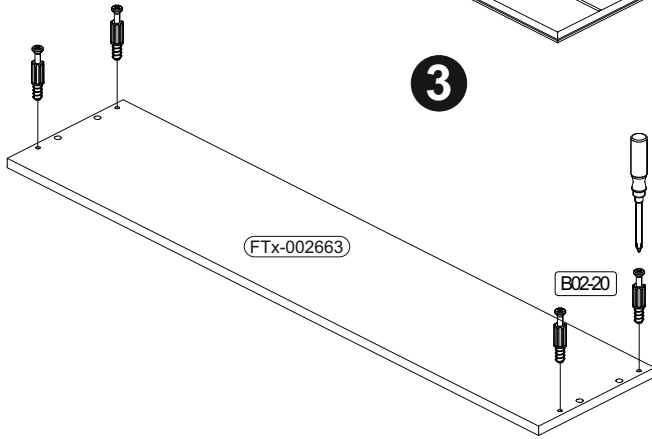
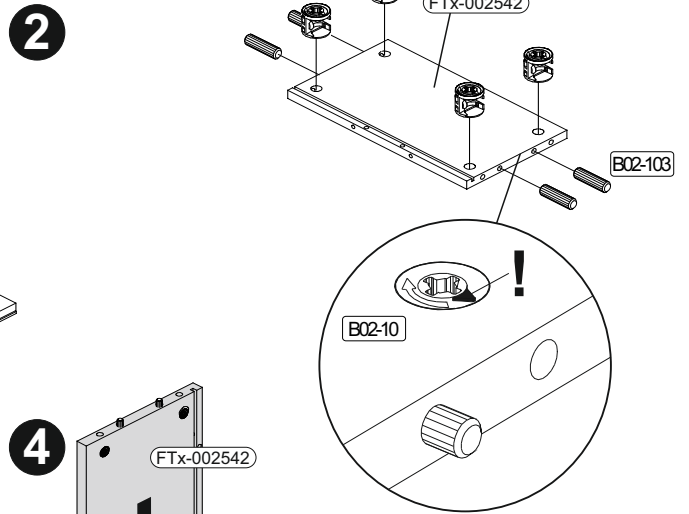
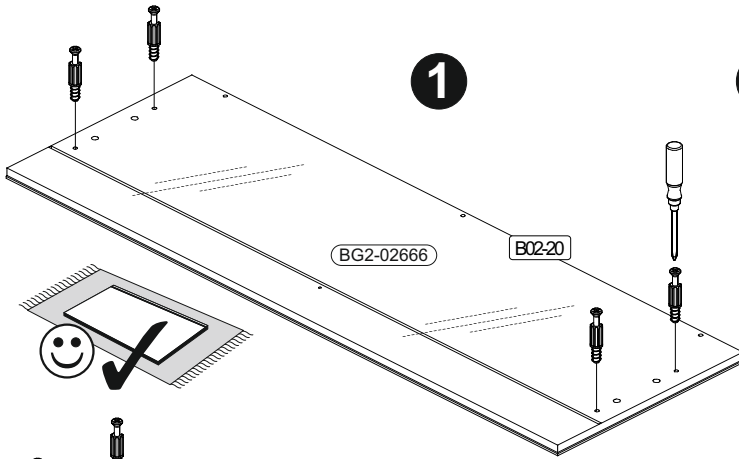

**15**

	<b>B02-10</b>		<b>B02-20</b>		<b>B02-103</b>		<b>B01-30</b>		<b>B01-122</b>	
	<b>16x</b>	$\varnothing 15 \times 12 \text{mm}$	<b>16x</b>	<b>16x</b>	<b>16x</b>	$8 \times 30$	<b>20x</b>	$3 \times 16$	<b>4x</b>	$4,0 \times 13$



16

		B02-10		B02-20		B02-103		B01-30	
		4x	ø15x12mm	4x		8x	8x30	10x	3x16

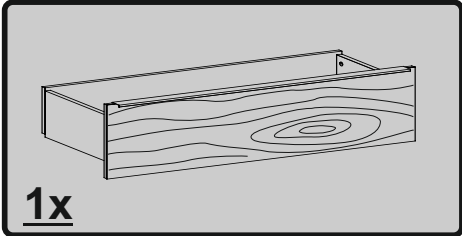
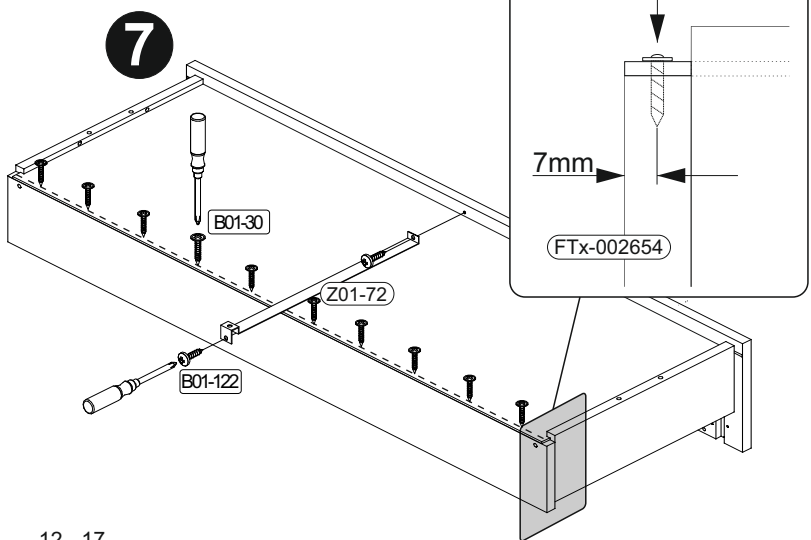
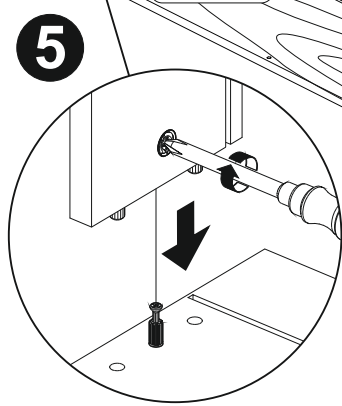
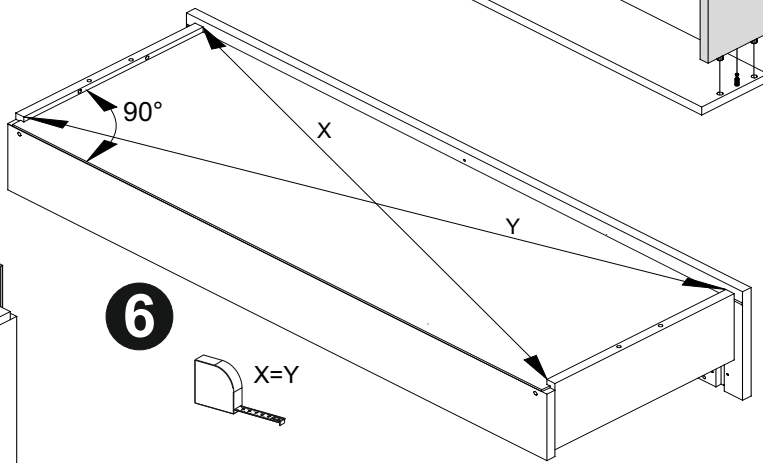
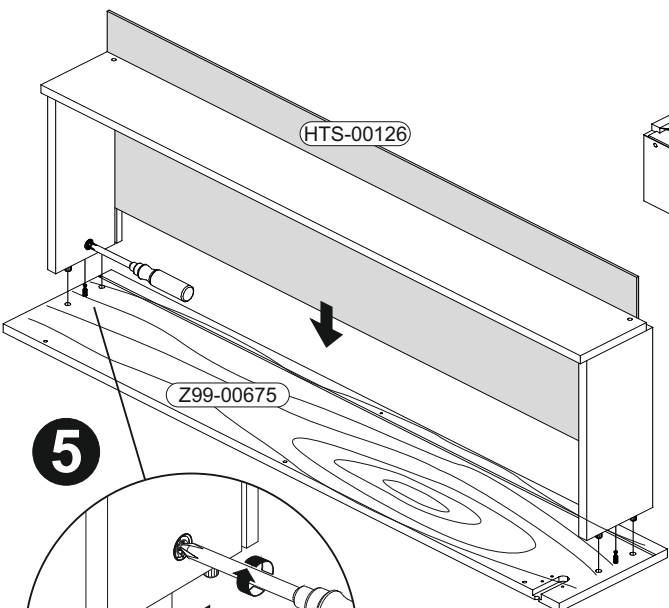
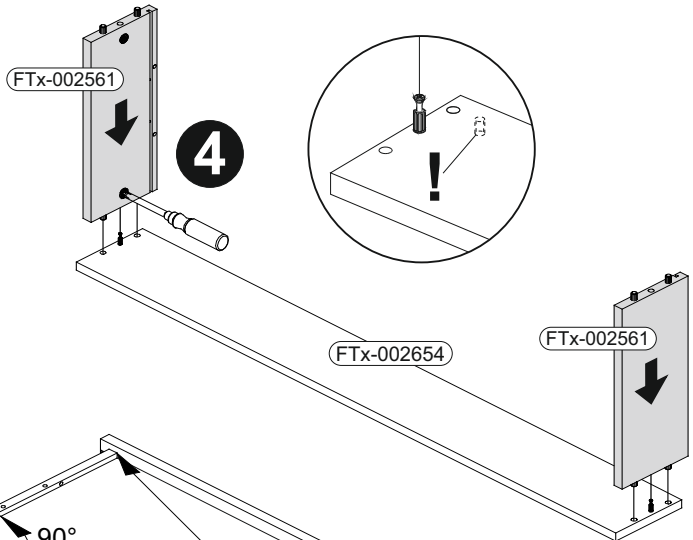
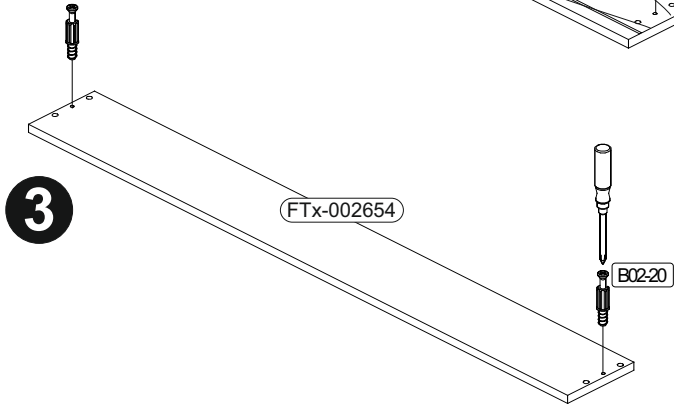
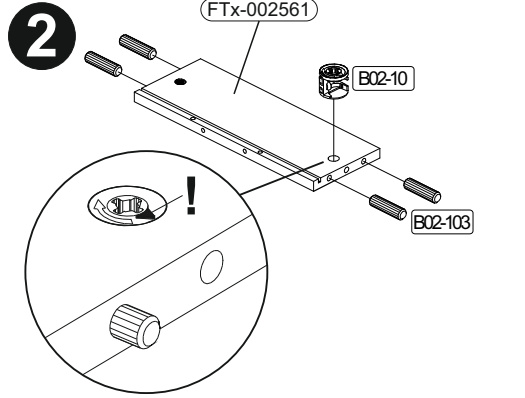
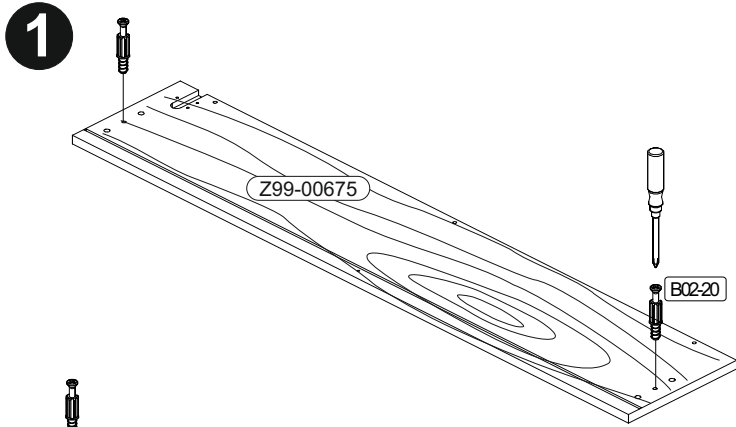

17

+	B01-200	3x	6,3x13
	B05-02		
	B05-02	4x	ø20mm

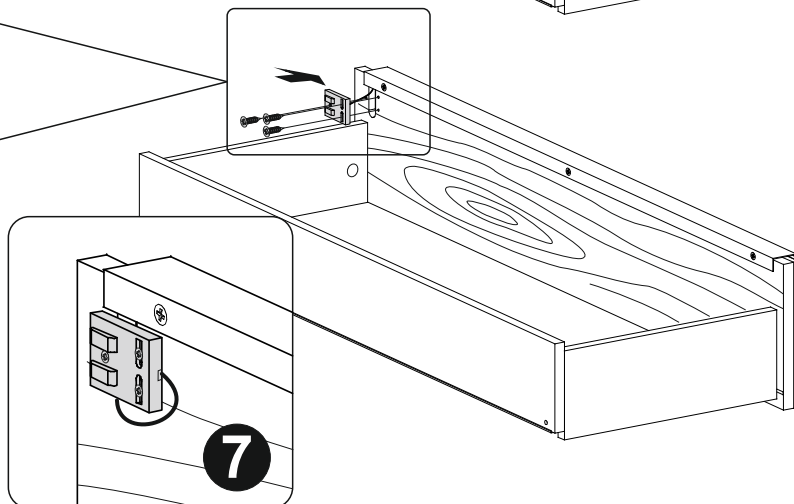
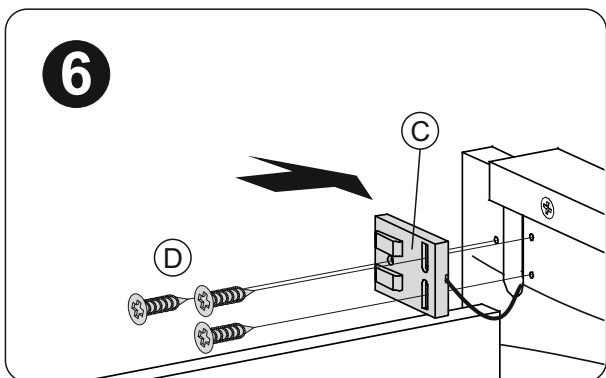
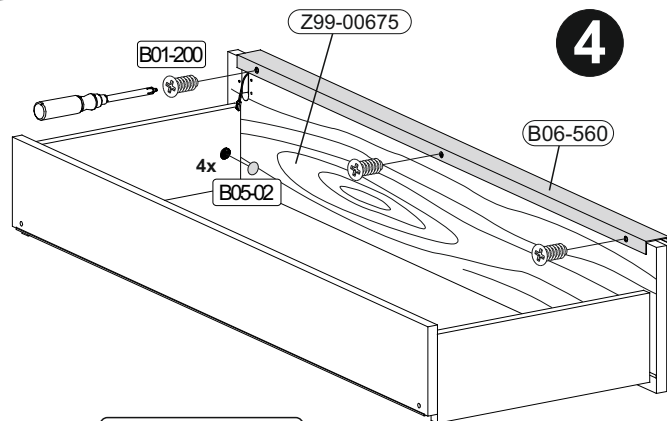
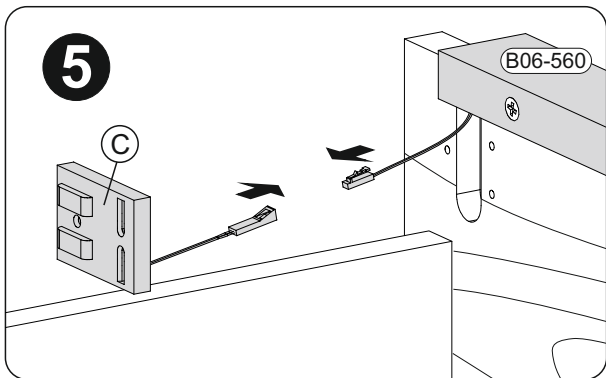
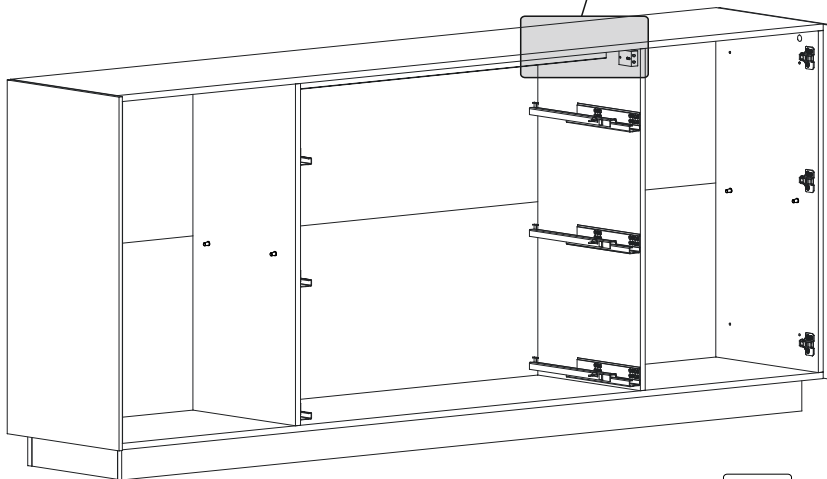
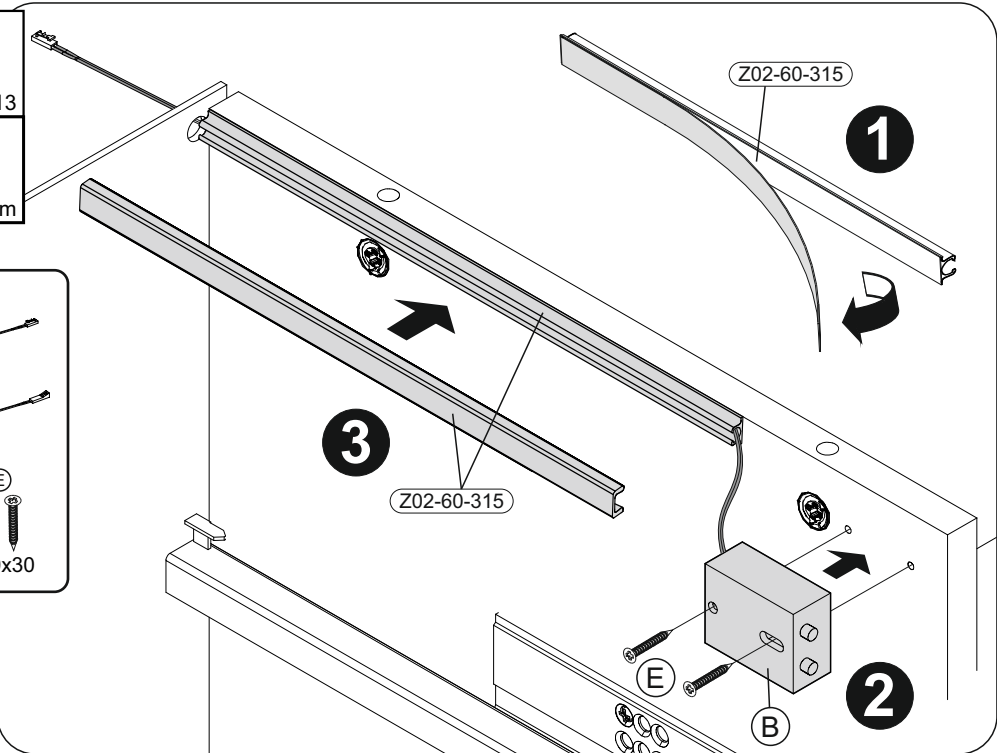
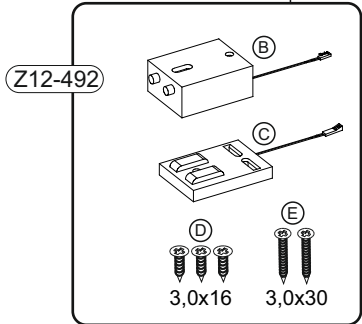

18

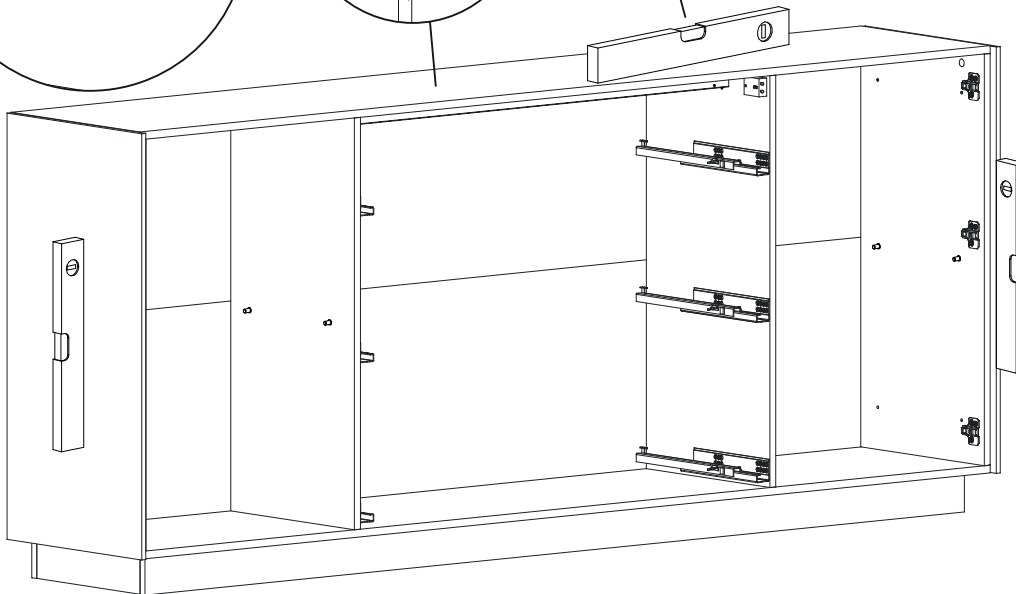
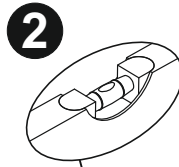
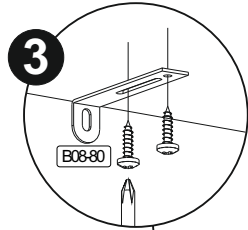
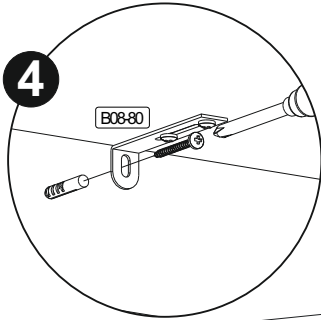
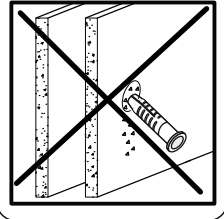
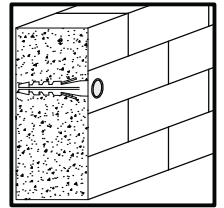
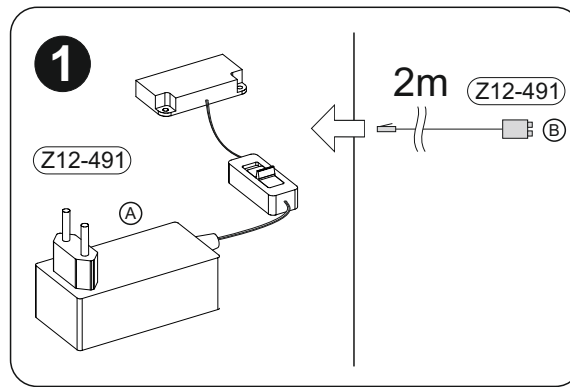
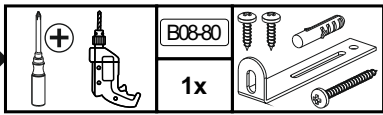

<b>Achtung • Attention • Attenzione • Opgelet • Uwaga • Pozor • Figelem • Atenție • Dikkat • Внимание • Fara • Vaara • Fare • Peligro</b>	
<b>(D)</b>	Wandbefestigung dient als Kippschutz - unbedingt anbringen! Bei einigen Wandtypen kann ein Spezialdübel erforderlich sein!
<b>(GB)</b>	The wall fastening serves to prevent tipping - be absolutely sure to mount it! For certain wall types, a special wall plug may be necessary!
<b>(FR)</b>	La fixation murale sert de protection contre le basculement – à installer impérativement ! Pour certains types de murs il faut des chevilles spéciales !
<b>(TR)</b>	Duvardaki sabitleme, devrilmeye karşı bir emniyet tedbiridir ve mutlaka monte edilmelidir! Bazı duvar tiplerinde bunun için özel bir dübel gerekli olabilir!
<b>(IT)</b>	Il fissaggio alla parete serve da protezione anti-ribaltamento – attaccarla assolutamente! Per alcune strutture di parete può essere necessario un tassello speciale!
<b>(NL)</b>	Bevestiging aan de muur dient als kantelbescherming – zeker en vast bevestigen! Bij enkele muurtypes is een speciale plug misschien vereist!
<b>(RU)</b>	Обязательно установите крепление на стене во избежание опрокидывания! Для некоторых типов стен может потребоваться специальный дюбель!
<b>(CZ)</b>	Montáž na stěnu slouží jako ochrana proti převrnutí – bezpodmínečně umístěte! U některých typů stěn může být zapotřebí speciální hmoždinka!
<b>(HU)</b>	A terméket a falhoz kel rögzíteni, különben az felborulhat! Egyes fal típusoknál speciális tiplit kell használni!
<b>(RO)</b>	Sistemul de fixare la perete servește ca protecție la răsturnare - de montat obligatoriu! Pentru unele tipuri de pereți este posibil să fie necesar un diblu special!
<b>(PL)</b>	Mocowanie do ściany jest jednocześnie zabezpieczeniem przed przewróceniem – koniecznie zamontować! Do niektórych rodzajów ścian koniecznie zastosować specjalne kołki mocujące.
<b>(SWE)</b>	Väggmontering fungerar som anti-lutningskydd - det är viktigt att fästa det! En speciell plugg kan behövas för vissa väggtyper!
<b>(FIN)</b>	Seinäkiinnitys toimii kaatumista estävänä suojana - se on ehdottomasti kiinnitettävä! Joihinkin seinätyypeihin voidaan tarvita erityistappi!
<b>(NOR)</b>	Veggmontering fungerer som anti-vippebeskyttelse - det er viktig å feste det! En spesiell dyvel kan være nødvendig for noen veggtyper!
<b>(DAN)</b>	Vægmontering fungerer som anti-vip beskyttelse - det er vigtigt at fastgøre det! En speciel dyvel kan være påkrævet til nogle vægtyper!
<b>(SK)</b>	Upevnenie na stenu slúži ako ochrana proti prevráteniu – bezpodmienečne použite! Pre niektoré druhy stien môže byť potrebná špeciálna hmoždinka!
<b>(ES)</b>	El montaje en la pared sirve como protección antivuelco: ¡es imprescindible fijarlo! ¡Es posible que se requiera una espiga especial para algunos tipos de paredes!

19

	B01-200		B05-02		B03-130	
	6x	6,3x13	16x	ø20mm	6x	

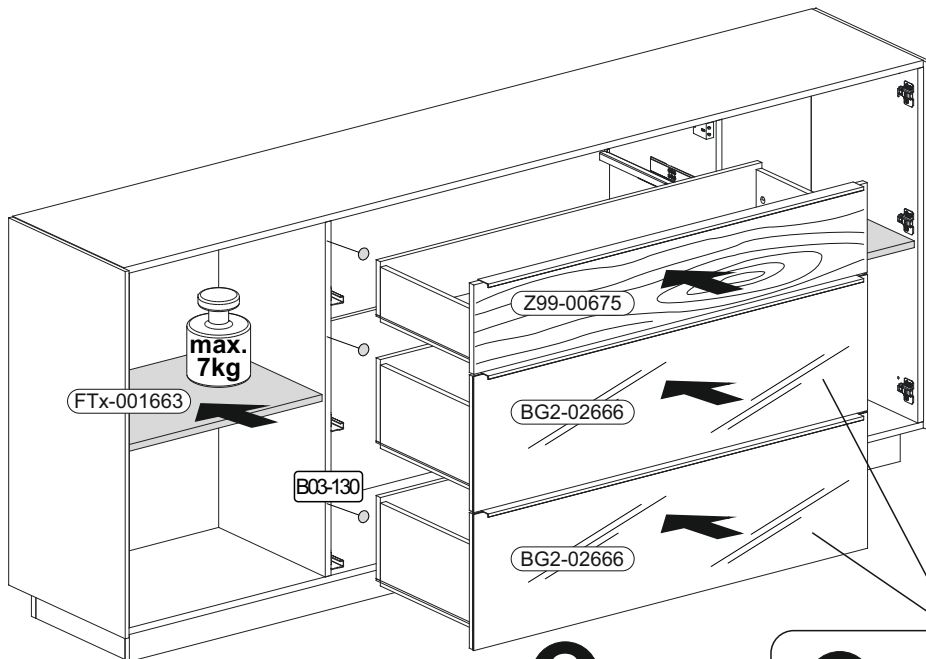
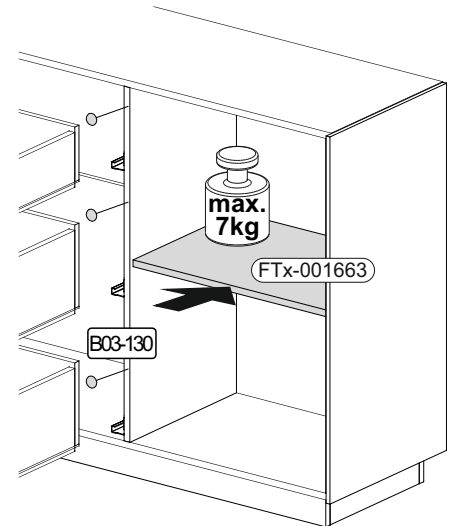
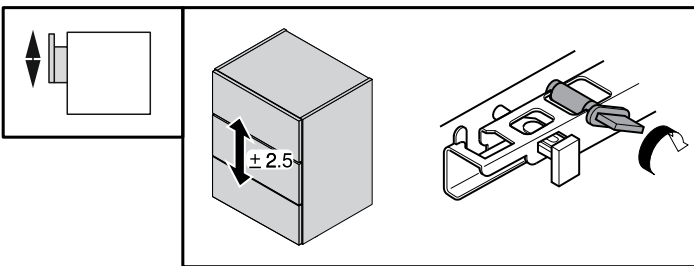
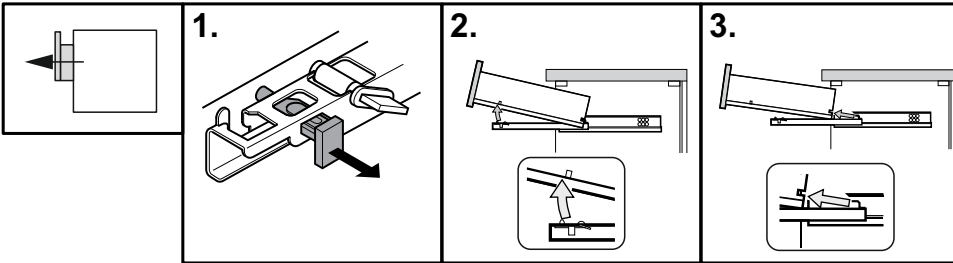
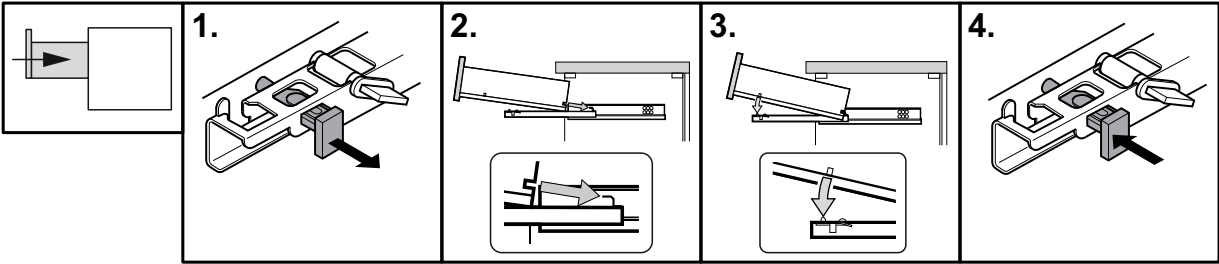

2

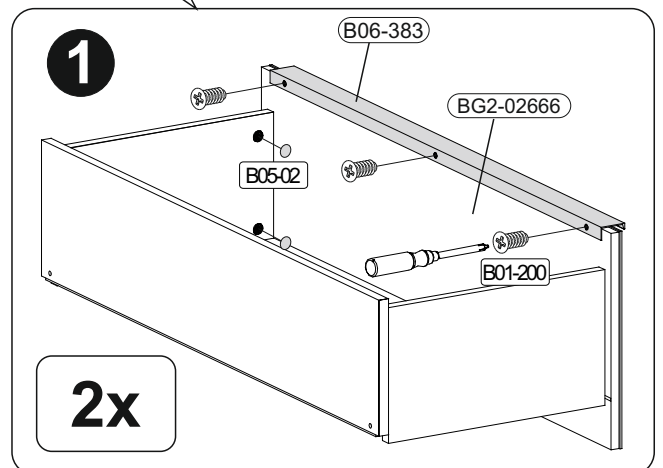

20

	B01-80		B03-01	
	12x	3,5x13	6x	

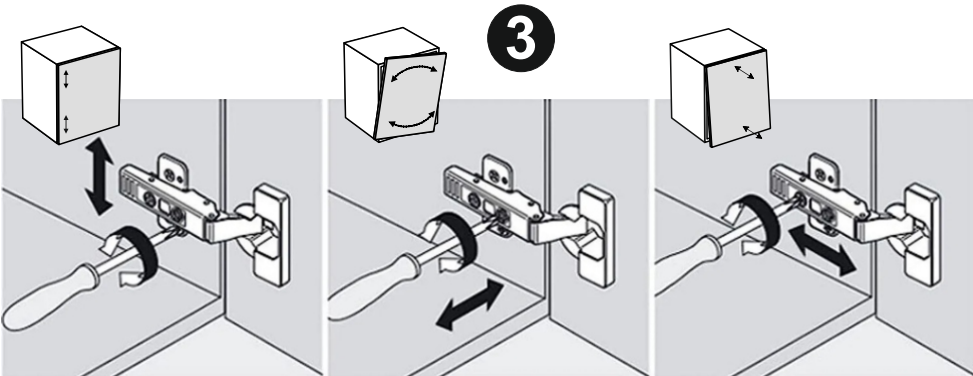
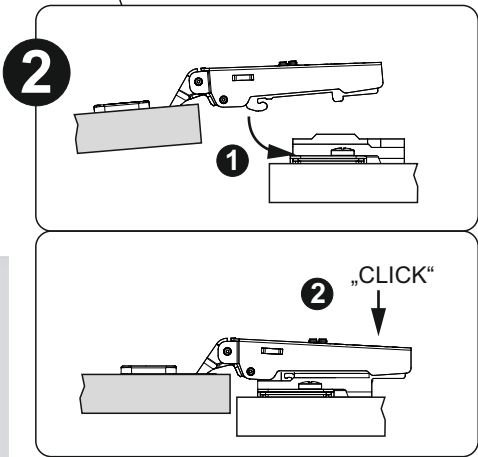
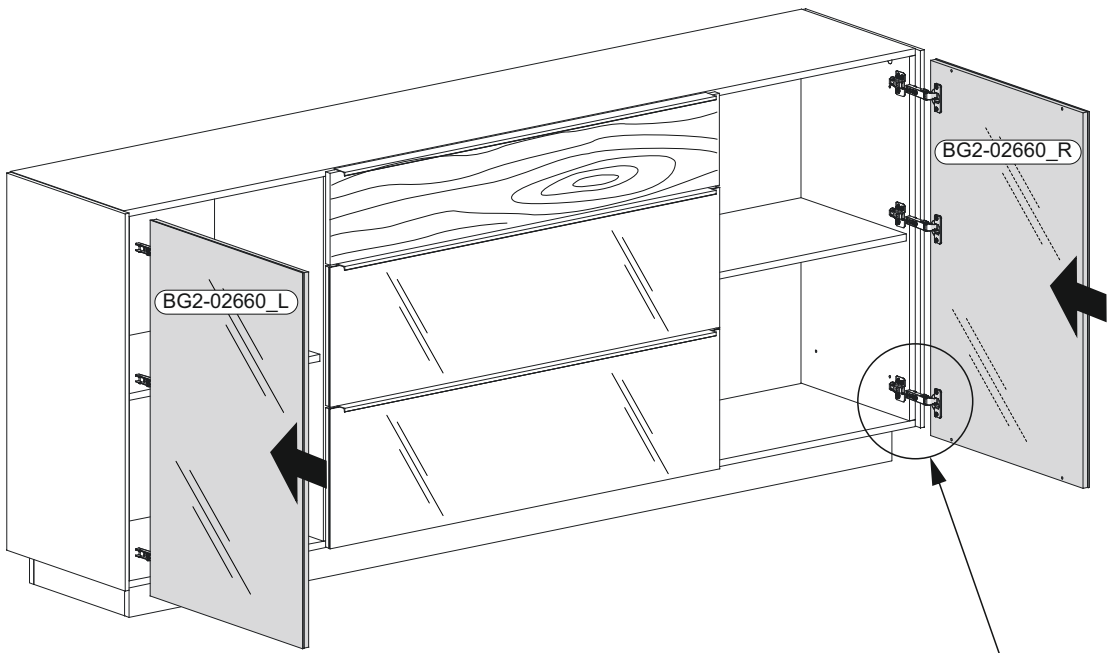
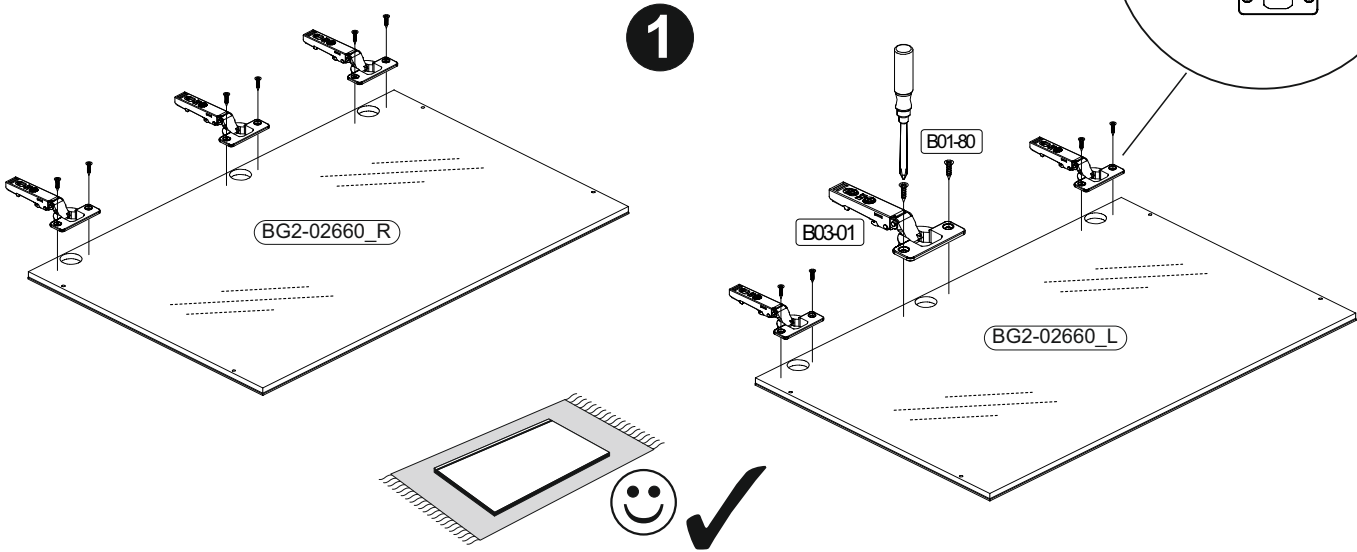
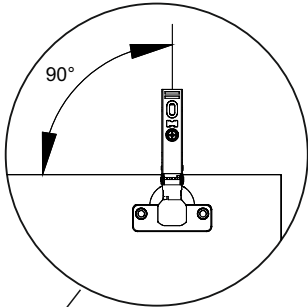

21

	B03-134		B01-200		B03-130	
	15x		4x	6,3x13	4x	

