

Gebrauchsanleitung PK-Nr. 2545
Instructions / Mode d'emploi / Gebruiksaanwijzing /
инструкция по использованию

PAIDI Möbel GmbH
Hauptstraße 87
D-97840 Hafenlohr

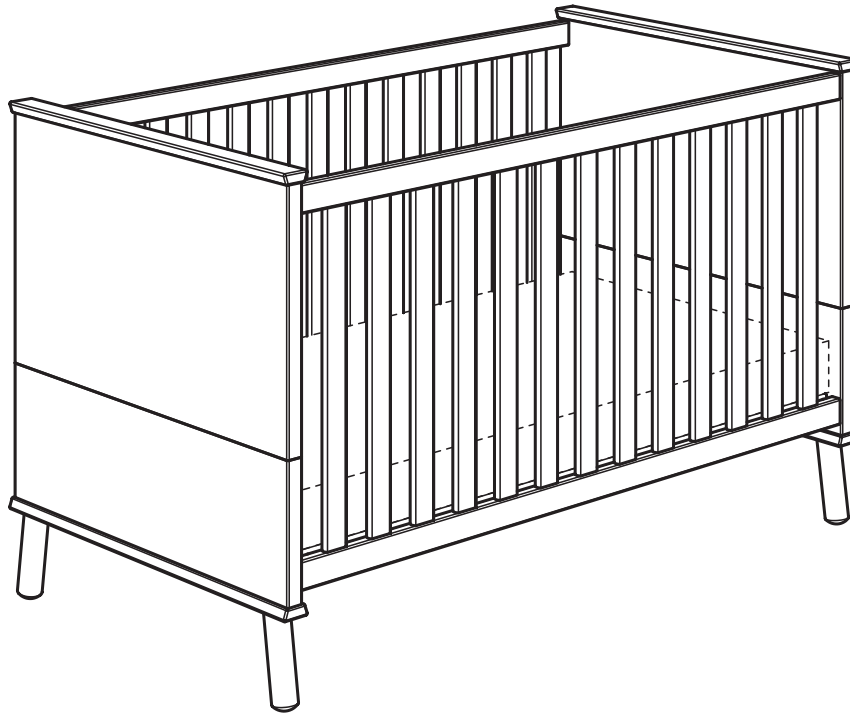

Kinderwelten



YLVIE
115 9011



www.blauer-engel.de/uz38

- emissionsarm
- Holz aus nachhaltiger Forstwirtschaft
- in der Wohnumwelt gesundheitlich unbedenklich



Seite 1 von 11

PK-Nr. 2545 Stand 01/2016 Ä: 09/2020

Warnhinweis!

Warning notice! / Avertissement! / Waarschuwing! /
Предупреждение!

PAIDI Möbel GmbH

Hauptstraße 87
D-97840 Hafenhöhr



Kinderwelten

V..

Vorbereitung / Preparation / La
préparation/ Voorbereiding /
подготовка

M..

Montage / Assembly /
Assemblage / Bijeenkomst /
МОНТАЖ

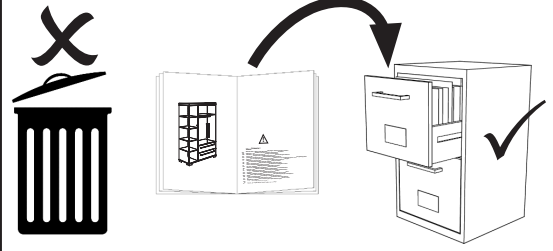

- DE** Schraubenverbindungen von Zeit zu Zeit auf ihre Festigkeit prüfen, gegebenenfalls nachziehen, da die Stabilität der Konstruktion sonst nicht gegeben ist.
- FR** Vérifier les connexions à vis de temps en temps, resserrer celles-ci le cas échéant, car, sinon, la stabilité de la construction ne serait pas assurée.
- GB** Check the tightness of the screw connections from time to time and tighten if necessary, as otherwise the stability of the construction is not assured.
- NL** Schroefverbindingen moeten van tijd tot tijd op hun stevigheid worden gecontroleerd en eventueel worden vastgedraaid, aangezien de stabiliteit van de constructie anders niet verzekerd is.
- ES** Compruebe de vez en cuando la firmeza de las uniones atornilladas y reapriete los tornillos si fuera necesario, pues de lo contrario quedaría afectada la estabilidad de la estructura.
- GR** Πού και πού ελέγχετε τη σταθερότητα των κοχλιωτών συνδέσεων κι εφ' όσον είναι ανάγκη, τις σφίγγετε ξανά, επειδή διαφορετικά δεν είναι η ευστάθεια της κατασκευής δεδομένη.
- IT** Controllare di tanto in tanto la tenuta delle connessioni a viti, all'occorrenza provvedere a serrarle di nuovo, poiché altrimenti non è garantita la stabilità della struttura.
- CZ** Čas od času zkontrolujte pevnost šroubových spojů, případně je dotáhněte, jinak nebude konstrukce stabilní.
- SL** Vijačne zveze od časa do časa preveriti glede na trdnost, po potrebi priviti, saj sicer stabilnost konstrukcije ne bo zagotovljena.
- PL** Połączenia śrubami sprawdzać od czasu do czasu pod kątem ich trwałości, ewentualnie dokręcać, gdyż inaczej konstrukcja nie jest stabilna.
- BG** Контролируйте от време на време дали болтовите съединения са добре завинтени, тъй като в противен случай не може да се гарантира стабилността на конструкцията.
- HR** Spojeve vijaka s vremena na vrijeme provjeriti u svezi čvrstoće, po potrebi stegnuti, jer inače nije zajamčena stabilnost konstrukcije.
- LT** Kartais patikrinkite varžtų jungčių stiprumą, prireikus suvėžkite juos stipriau, nes priešingu atveju konstrukcija nebus stabilii.
- RU** Перепроверяйте время от времени болтовые соединения. Они должны быть плотно затянуты. Это гарантирует стабильность конструкции.
- CN** 请经常的检查连接处的螺丝，如有发现松动请及时锁紧，否则将无法保障其稳定性。

- DE** **Pflegehinweis: Zum Reinigen der Oberflächen ein leicht-feuchtes Tuch oder ein handelsübliches Möbelpflegemittel verwenden.**
- FR** Indication sur l'entretien : pour nettoyer les surfaces, utiliser un chiffon légèrement humide ou un nettoyeur pour meubles en vente dans le commerce
- GB** Caring for the... : In order to clean the surfaces please use a slightly damp cloth or commercially available furniture care product.
- NL** Verzorgingsaanwijzing: Voor het reinigen van de oppervlakken een licht vochtig doek of een gebruikelijk meubelschoonmaakmiddel gebruiken.
- ES** Recomendaciones de cuidado: Para limpiar las superficies del mueble debe usar un trapo humedecido o un producto de limpieza de muebles comercial.
- GR** Οδηγίες περιποίησης: Για το καθάρισμα των επιφανειών να χρησιμοποιείτε ένα ελαφρά νοτισμένο πανάκι ή λούστρο επίπλων.
- IT** Indicazione per pulizia e cura: Per la pulizia delle superfici utilizzate un panno leggermente umido o un normale prodotto per la cura dei mobili.
- CZ** Pokyny k čištění: Na čištění povrchu použijte pouze navlhčený kousek látky nebo běžný prostředek na ošetřování nábytku.
- SL** Navodilo za nego: Za čiščenje površin uporabljajte malo vlažno cunjko ali trgovsko običajno sredstvo za nego pohištva.
- PL** Wskazówka pielęgnacyjna: do czyszczenia powierzchni stosować lekko wilgotną ściereczkę lub zwykły środek do pielęgnacji mebli.
- BG** Указание за поддържане: Използвайте леко навлажнена кърпа или обикновен препарат за поддържане на мебели, за да почистите повърхностите.
- HR** Upute za njegu: Za čišćenje površina upotrijebiti jednu lako navlaženu krpu i trgovačko uobičajeno sredstvo za njegu namještaja.
- LT** Rekomendacija priežiūrai: Paviršius valykite drėgna pašluoste arba parduotuvėse įsigytomis baldų priežiūros priemonėmis.
- RU** Рекомендации по уходу: для очистки поверхностей используйте слегка влажную тряпку или обычное средство по уходу за мебелью.
- CN** 保养说明: 清洁表面只需用稍微潮湿的布或普通的家具清洁剂即可。

Beschläge

Fittings / Raccords / Fittingen / кованный

PAIDI Möbel GmbH
Hauptstraße 87
D-97840 Hafenlohr







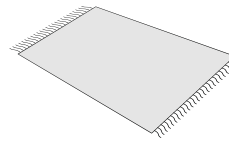
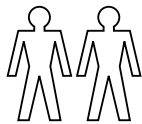
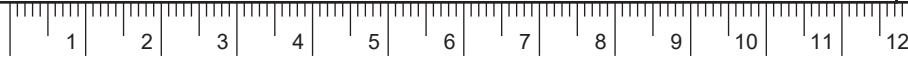



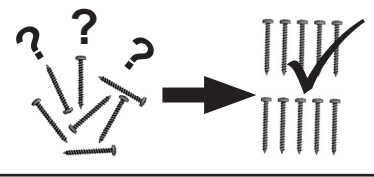

Kinderwelten

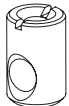
1:1
DIN A4

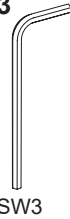
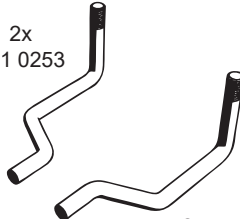

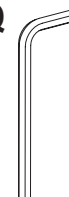
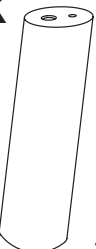
ca. 0,5h

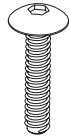

<p>B</p>  <p>8x 681 0775</p>	<p>C</p>  <p>8x 681 0773</p>	<p>D2</p>  <p>8x 681 0784</p>	<p>D3</p>  <p>SW3 1x 681 3009</p>	<p>E</p>  <p>2x 681 0253</p>	<p>F</p>  <p>4x 681 2047</p>	<p>Q</p>  <p>SW4 1x 681 3011</p>
<p>K</p>  <p>4x 681 8061</p>	<p>L</p>  <p>ø5 x 25 4x 681 0351</p>	<p>M</p>  <p>M6 x 35 4x 681 3954</p>	<p>N</p>  <p>ø8 x 45 8x 681 0402</p>	<p>O</p>  <p>6,3 x 50 6x 681 5311</p>		

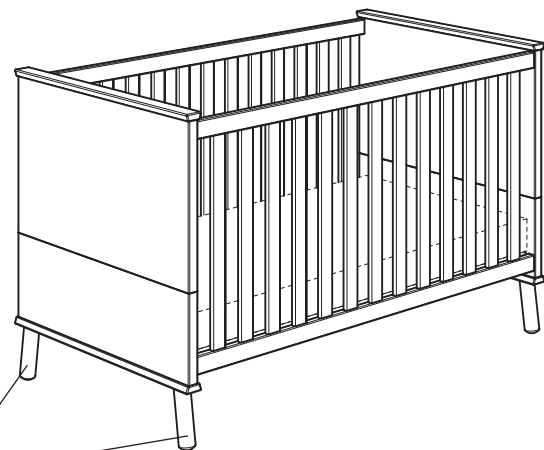
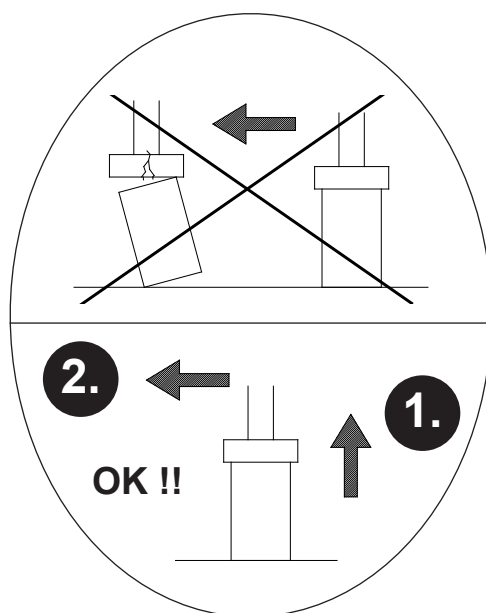

V1.1

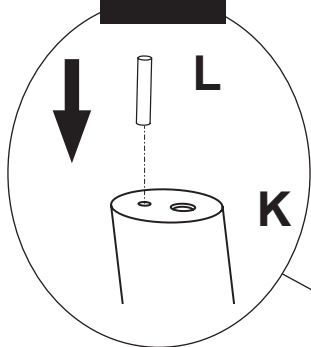



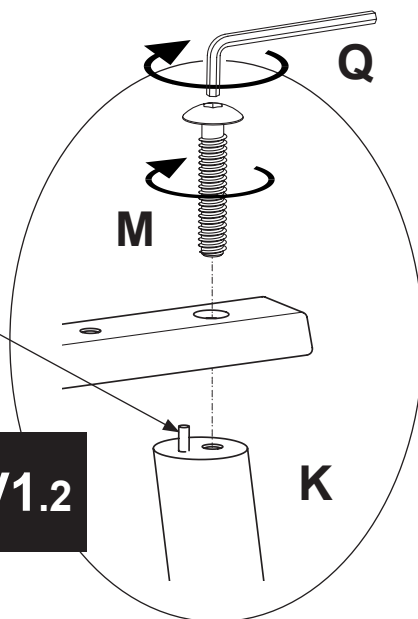

V1.2

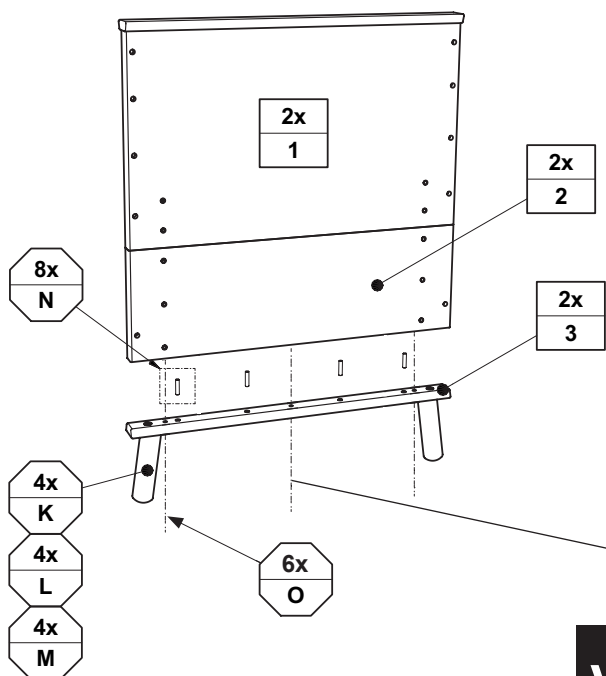
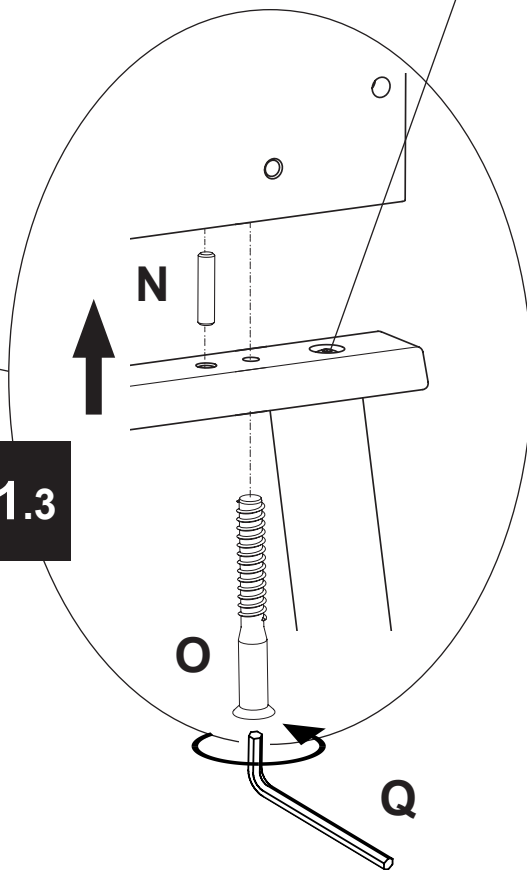

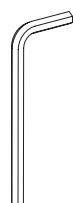
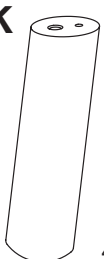
V1.3

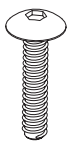

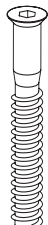
Q 	K 	L 	M 	N 	O 
SW4 1x 681 3011	4x 681 8061	ø5 x 25 4x 681 0351	M6 x 35 4x 681 3954	ø8 x 45 8x 681 0402	6,3 x 50 6x 681 5311

V2

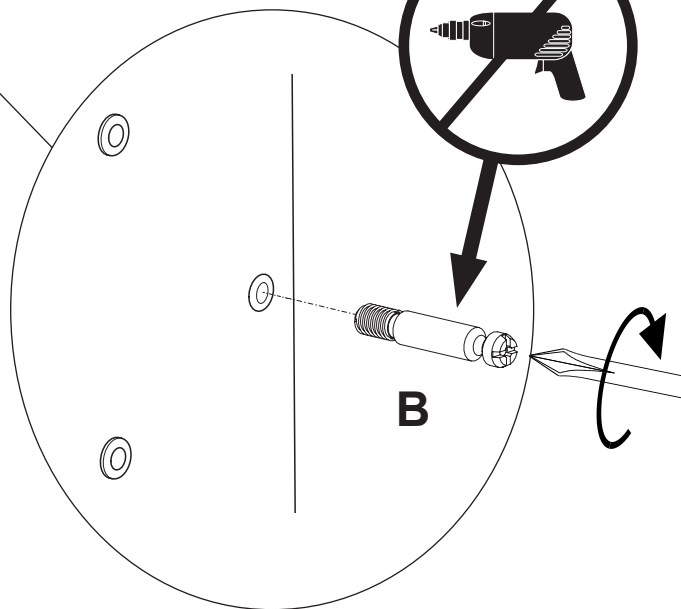
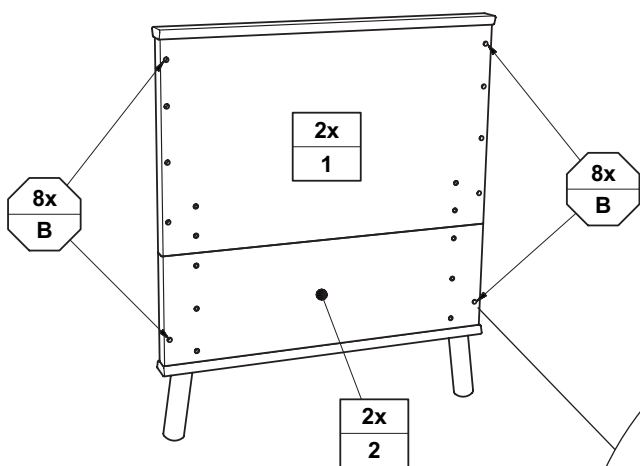

B



8x
681 0775

V3

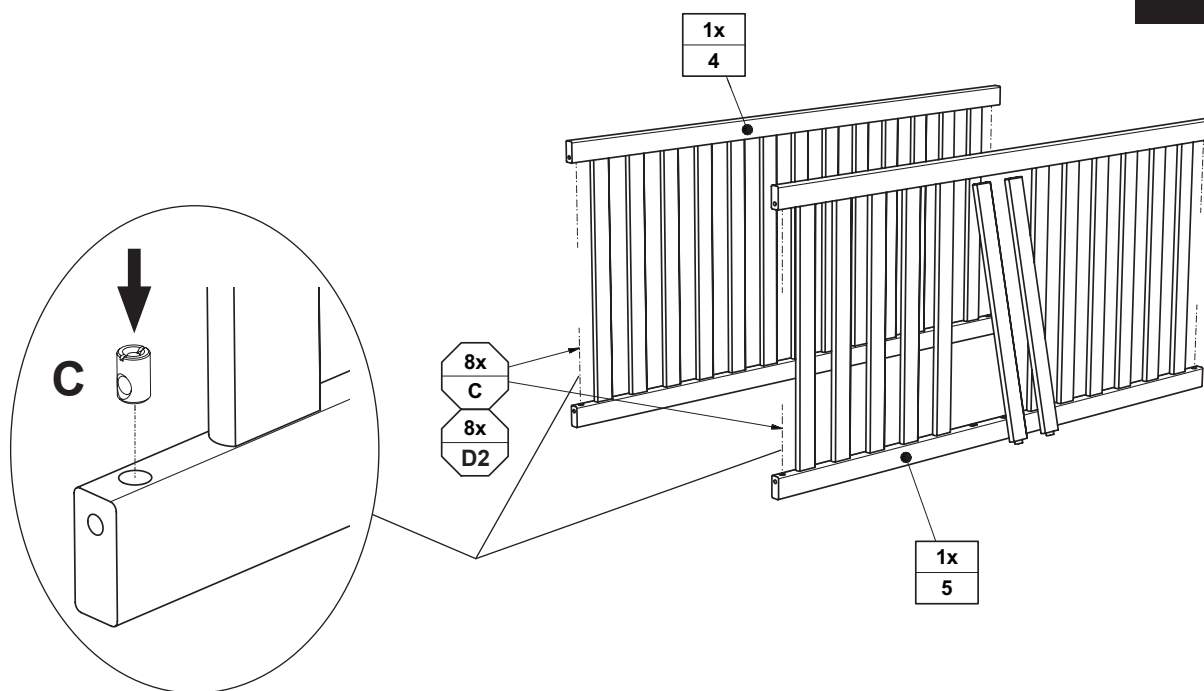

C



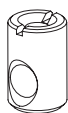

C

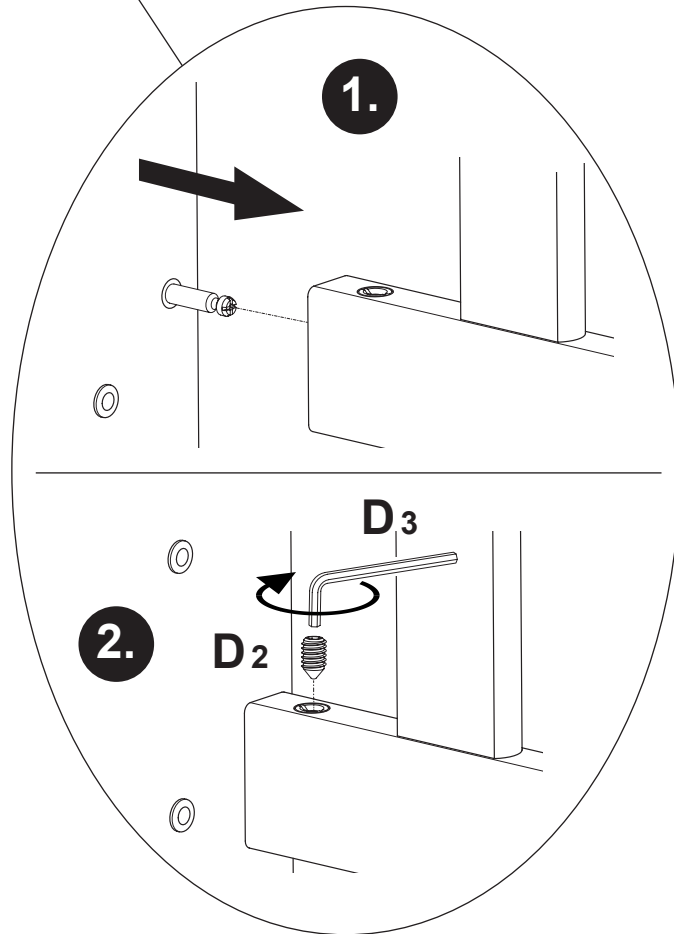
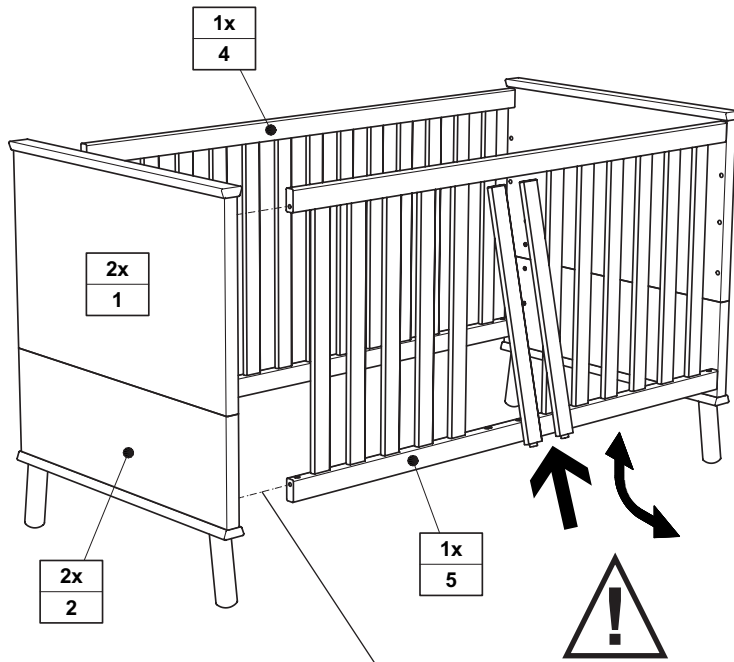

8x
681 0773

M1



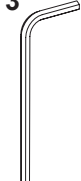

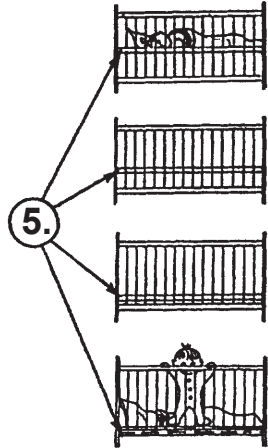
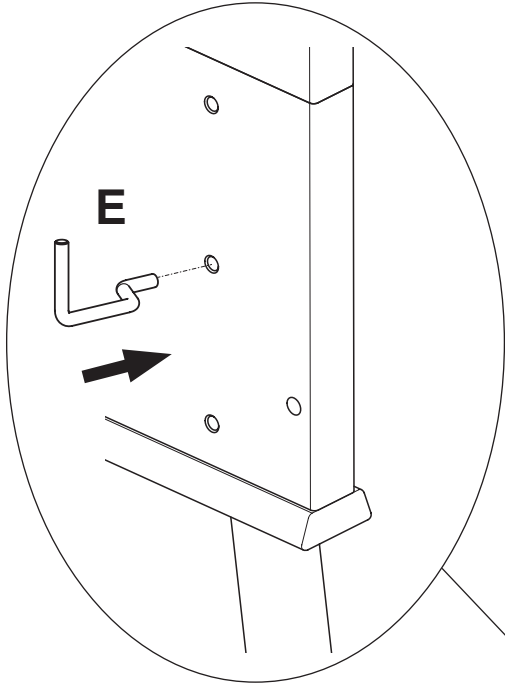
D2	D3
	
8x 681 0784	SW3 1x 681 3009

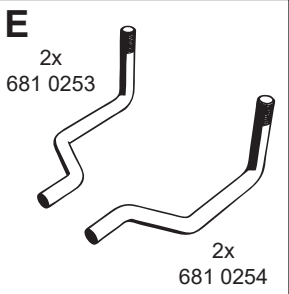
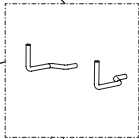

2x
E

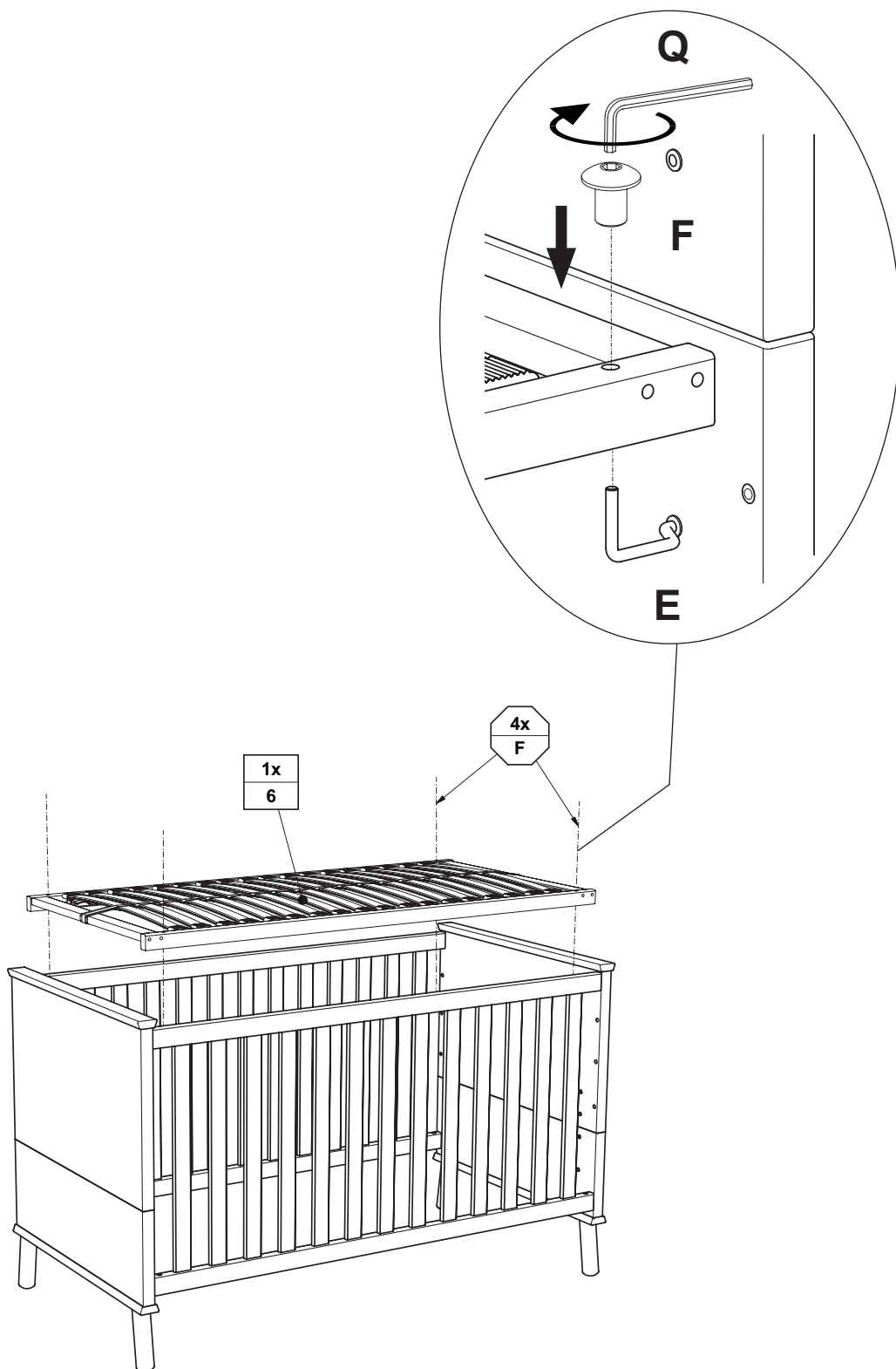



F	Q
	
4x 681 2047	SW4 1x 681 3011

Gebrauchsanleitung Umbau zum Juniorbett

Instructions for reconstruction to the junior bed / Mode d'emploi pour la transformation en lit junior / Gebruiksaanwijzing ombouwen tot juniorbed / Инструкция по переводу на младшую кровать

V1

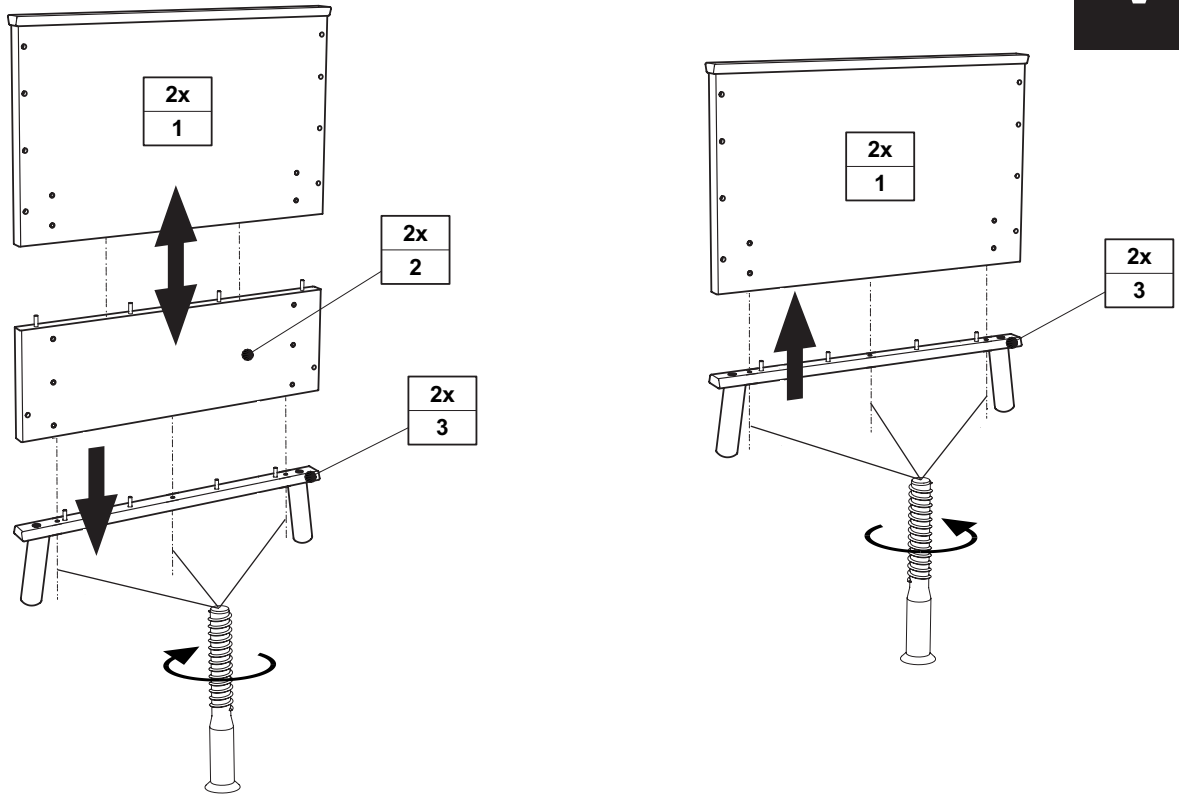

V2

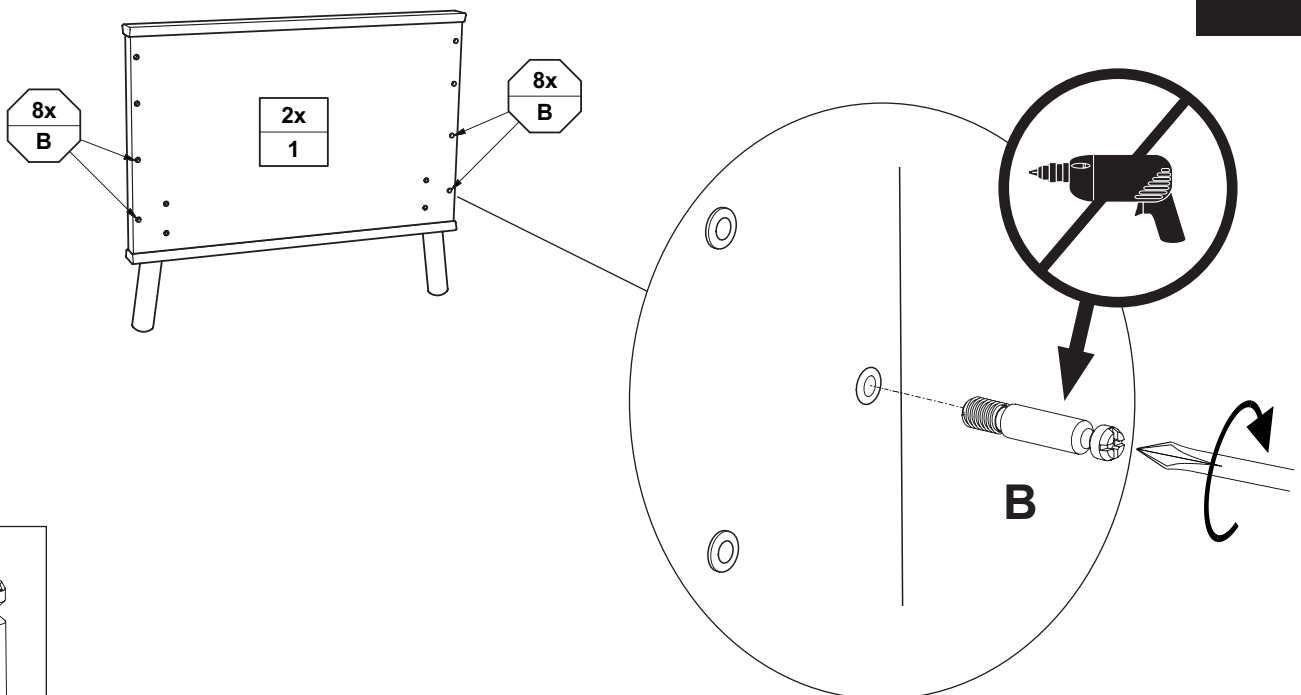

B



8x

681 0775

Seite 9 von 11

PK-Nr. 2545 Stand 01/2016 Ä: 09/2020



Umbauseiten sind nicht im Lieferumfang enthalten.
Separat bestellen !

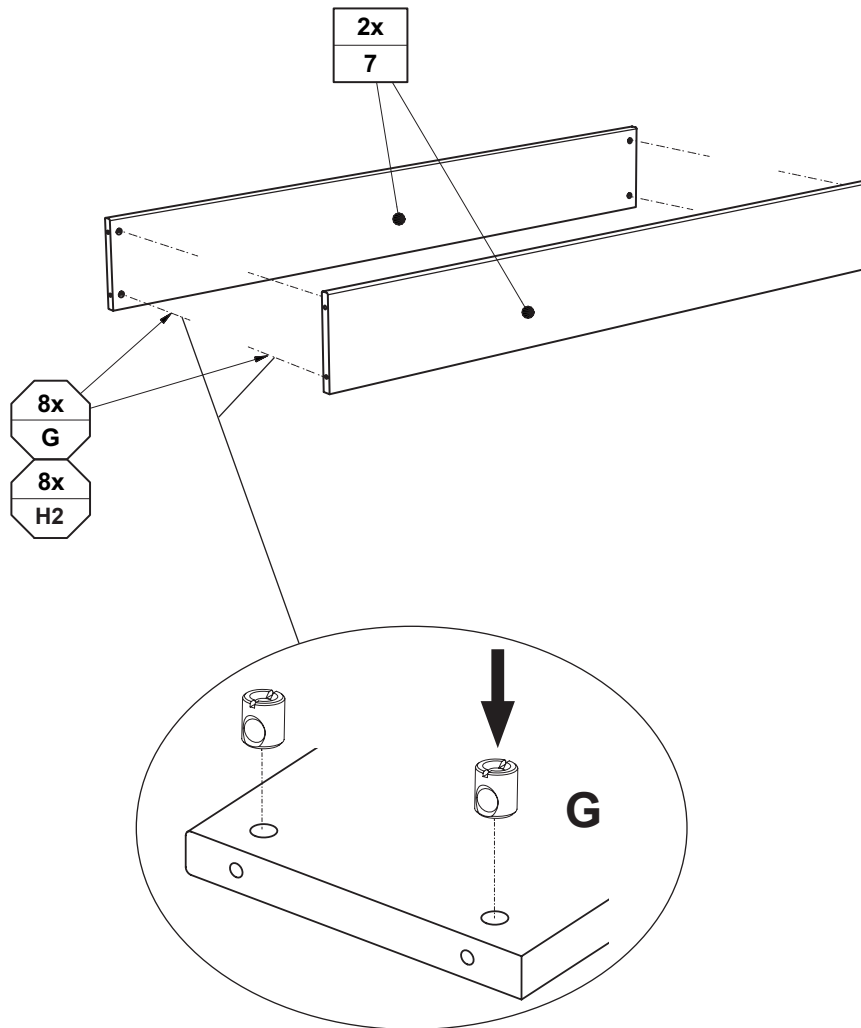

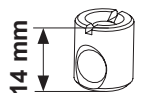

G

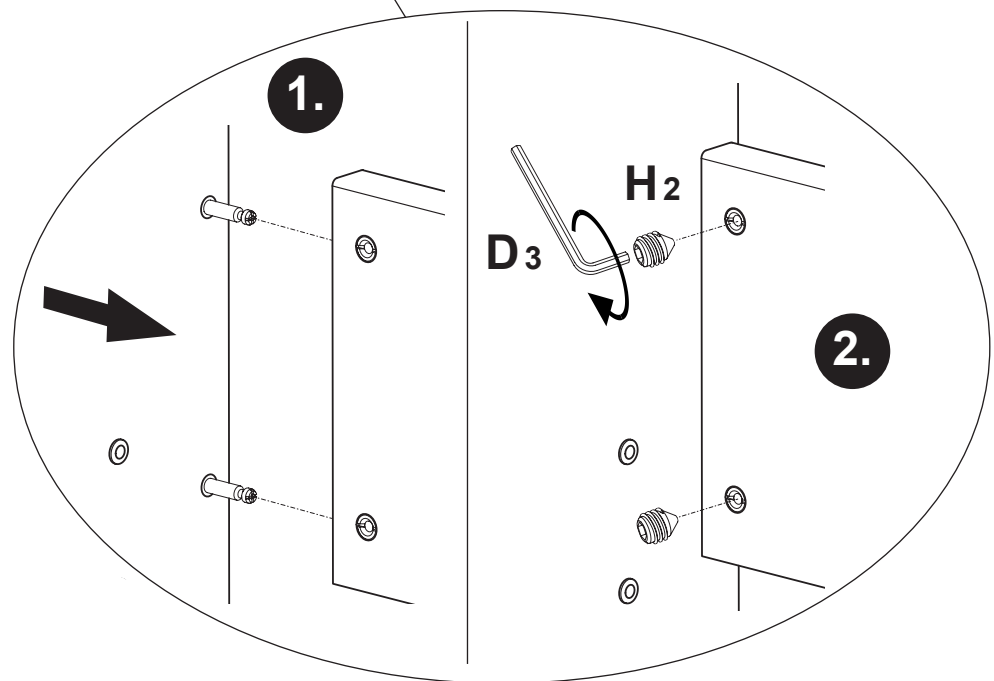
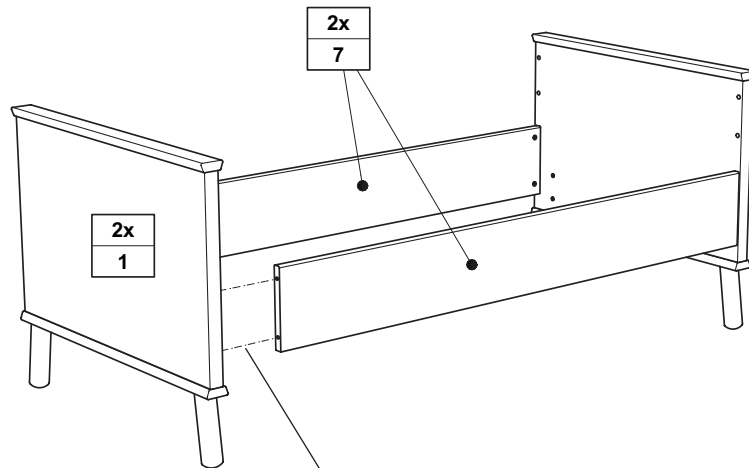

14 mm

8x
681 0776

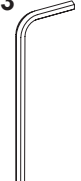

H2	D3
	
8x 681 0787	SW3 1x 681 3009