

ca. 33 cm

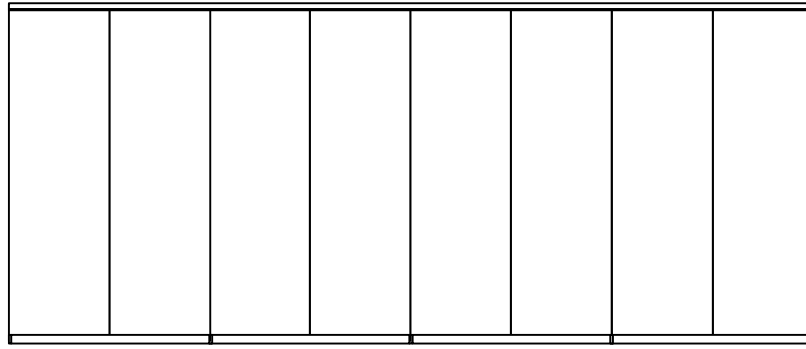

ca. 400 cm

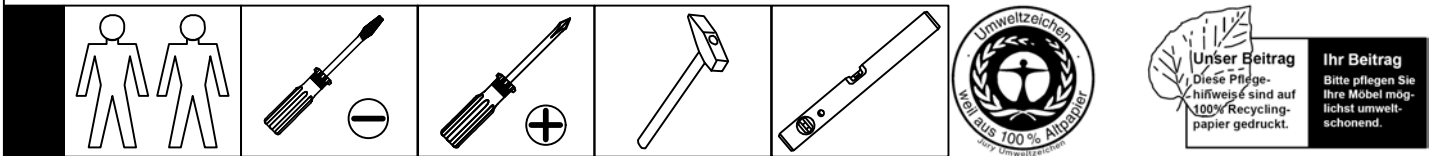

DEUTSCH – Alle Pakete öffnen und alle Aufbauanleitungen lesen. Fachkundige Montage erforderlich. Unsachgemäße Montage kann zu Unfällen führen. Möbel/Gegenstand könnte kippen oder umfallen. **WICHTIG!** Achten Sie darauf, dass Sie Schrauben/Beschläge entsprechend der Wand-/Deckenbeschaffenheit und mit ausreichender Tragfähigkeit verwenden. Erkundigen Sie sich ggf. beim Eisenwarenfachhandel.

Română - Toate ofertele se pot deschide și citi toate instrucțiunile de asamblare. Este necesar un montaj profesional. Un montaj neprofesional poate duce la accidente. Mobilă / corpul de mobilă se poate inclina și cadea. **IMPORTANT!** Asigurați-vă ca suruburile și toate celelalte fitinguri se potrivesc tipului de material din care este construit peretele sau tavanul și ca au o rezistență suficientă la preluarea sarcinii. Dacă este necesar, solicitați sprijin specializat în magazinul de fitinguri.

MAGYAR - Minden nyitott csomagokat és az összes összeszerelési utasításokat olvasni. Az összeszerelés lehetôleg hozzáértô személy végezze, mert nem megfelelô, hibás össze-, ill. felszerelés esetén a bútor feldôlhet, leszakadhat a falról, ezzel személyi sérülést vagy balesetet okozva. **FIGYELEM!** Válasszon olyan csavart, tiplít mely leginkább alkalmas az Ön otthonában található fal / mennyezet anyagához, és teherbíró képessége is megfelelo.

ITALIANO- Tutti i pacchetti aperti e leggi tutte le istruzioni per l'uso. Importante un montaggio corretto. Un montaggio sbagliato può causare incidenti. Assicurarsi di fissare il mobile alla parete o al soffitto con viti/accessori adatti in modo che non puo ribaltarsi o cadere. Usare solo ferramenta speciale. Il produttore non si assume nessuna responsabilità in caso di danni a persone o cose.

Português – Todos os pacotes podem abrir e ler todas as instruções de montagem. Montagem só de pessoas experientes. A montagem incorreta pode levar a acidentes. Móveis/objeto poderia cair. **IMPORTANTE!** Dê atenção que os parafusos / as guarnições correspondem à qualidade das paredes e que têm capacidade suficiente para a carga. Informa se eventualmente numa loja de ferrugens.

NEDERLANDS - Alle pakketten kunnen openen en lezen alle montage-instructies. De montage dient te worden uitgevoerd door een vakbekwaam iemand. Foutieve montage kan er toe leiden dat het meubel/voorwerp kantelt of omvalt en iets beschadigt resp. iemand bezeert. N.B. Denk er aan dat de schroeven of het beslag dat je kiest geschikt moeten zijn voor de wand/het plafond waarin ze vastgezet moeten worden, en voldoende draagkracht moeten hebben. Neem bij twijfel contact op met de lokale vakhandel.

Česky - Všechny otevřené balíky a všechny montážní pokyny přečtete. Montáž by měl provést kvalifikovaný odborník. Nesprávná montáž může zapříčinit, že nábytek se může převrátit nebo se některý díl uvolnit. Může tak dojít ke zranění člověka či dalším škodám. **UPOZORNĚNÍ:** zvolte šrouby a kování, které jsou vhodné pro daný typ nábytku a mají postačující spojovací nosnost. Nejste-li si jisti, obraťte se na nejbližší specializovaný obchod.

Español - Todos los paquetes pueden abrir y leer todas las instrucciones de montaje. Montaje de expertos necesario. Un montaje inadecuado puede dar lugar a accidentes. Muebles / objeto podría inclinar o caerse. **¡IMPORTANTE!** Asegúrese de que utiliza los tornillos / accesorios de acuerdo con las propiedades adecuadas para pared / techo y con capacidad de peso suficiente. Infórmese en su ferretería.

ENGLISH - All packages can open and read all the assembly instructions. The assembly should be carried out by a qualified person, due to the fact that wrong assembly can lead to that the furniture/object topples or falls resulting in personal injury or damage. **NOTE!** Choose screws and fittings that are specially suited to the material in your wall/ceiling and have sufficient holding power. If you are uncertain, contact your local specialised retailer.

Türkçe - Tüm paketler tüm montaj talimatları açıp okuyabilirsiniz. Uzman bir kişi tarafından montaj edilmelidir. Yanlış bir kurulum mobilyanızın üzerine düşmesine ve/veya tamamen dağılmasına neden olabileceği için kazalara ve yaralanmalara yol açabilir. **ÖNEMLİ!** Lütfen Dikkat Ediniz. Duvar yapısına göre yeterli kapasitede ve tasıma kabiliyetinde olan vidalar/parçalar kullanınız. Gerekirse bir uzmana ve/veya yapı-market mağazasına danışabilirsiniz.

POLSKI - Wszystkie pakiety mogą otworzyć i przeczytać wszystkie instrukcje montażu. Mebel powinien być montowany przez osobę do tego uprawnioną. Następstwem niewłaściwego montażu mebla może być przechylenie lub nawet przewracanie się mebla, w wyniku czego może dojść do uszkodzenia mebla i jego zawartości a nawet do wypadku. **UWAGA!** Okucia, śruby, haki jak i kolki muszą być dopasowane do wagi mebla z zawartością oraz do specyficznych właściwości muru lub sufitu. W przypadku wątpliwości prosimy zasięgnąć porady fachowca.

FRANÇAIS - Tous les forfaits peuvent ouvrir et lire toutes les instructions de montage. Le montage doit être effectué par une personne compétente. Un montage mal effectué peut provoquer la chute du meuble/de l'objet et blesser quelqu'un. **ATTENTION !** Adaptez les vis et ferrures au matériau du mur/plafond et au poids de l'objet. En cas de doute, demandez conseil à un vendeur spécialisé.

SLOVENSKY - Vsi paketi lahko odprete in preberete vsa navodila za montažo. Montáž by mala vykonat kvalifikovaná osoba. Pri nesprávnej montáži môže dôjsť k prevrhnutiu alebo pádu nábytku/objektu a k prípadnému zraneniu osôb alebo poškodeniu majetku. **UPOZORNENIE!** Použite skrutky a kovanie, ktoré sú vhodné na použitie do materiálu danej steny/stropu a majú dostatočnú nosnosť. Ak si nie ste istí, obráťte sa na špecializovaného predajcu.

Русский - Все пакеты можно открыть и прочитать все инструкции по сборке. монтаж должен производиться специалистом. Неправильная установка может привести к несчастному случаю. Мебель может опрокинуться или упасть. **ВАЖНО:** Следите за тем, чтобы выбранные шурупы и другие крепежно-монтажные детали были достаточно прочно закреплены. Подробную информацию можете получить в специальных магазинах.

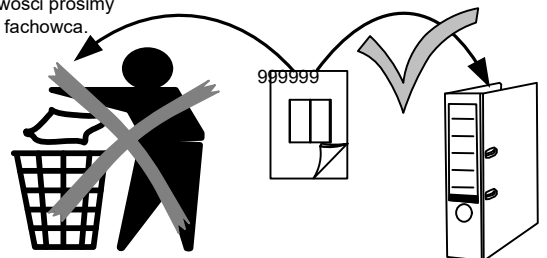

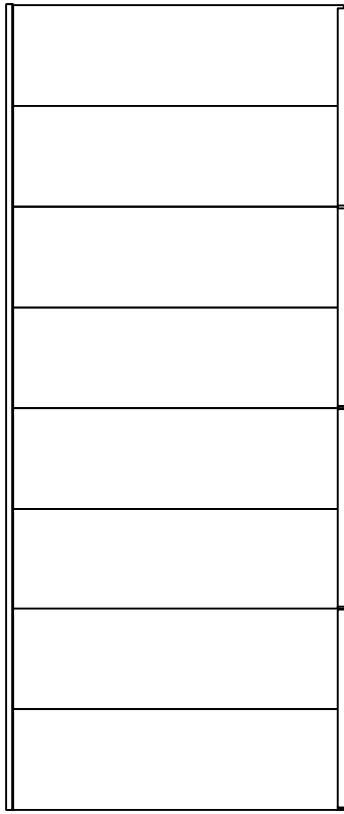

ca. 400 cm

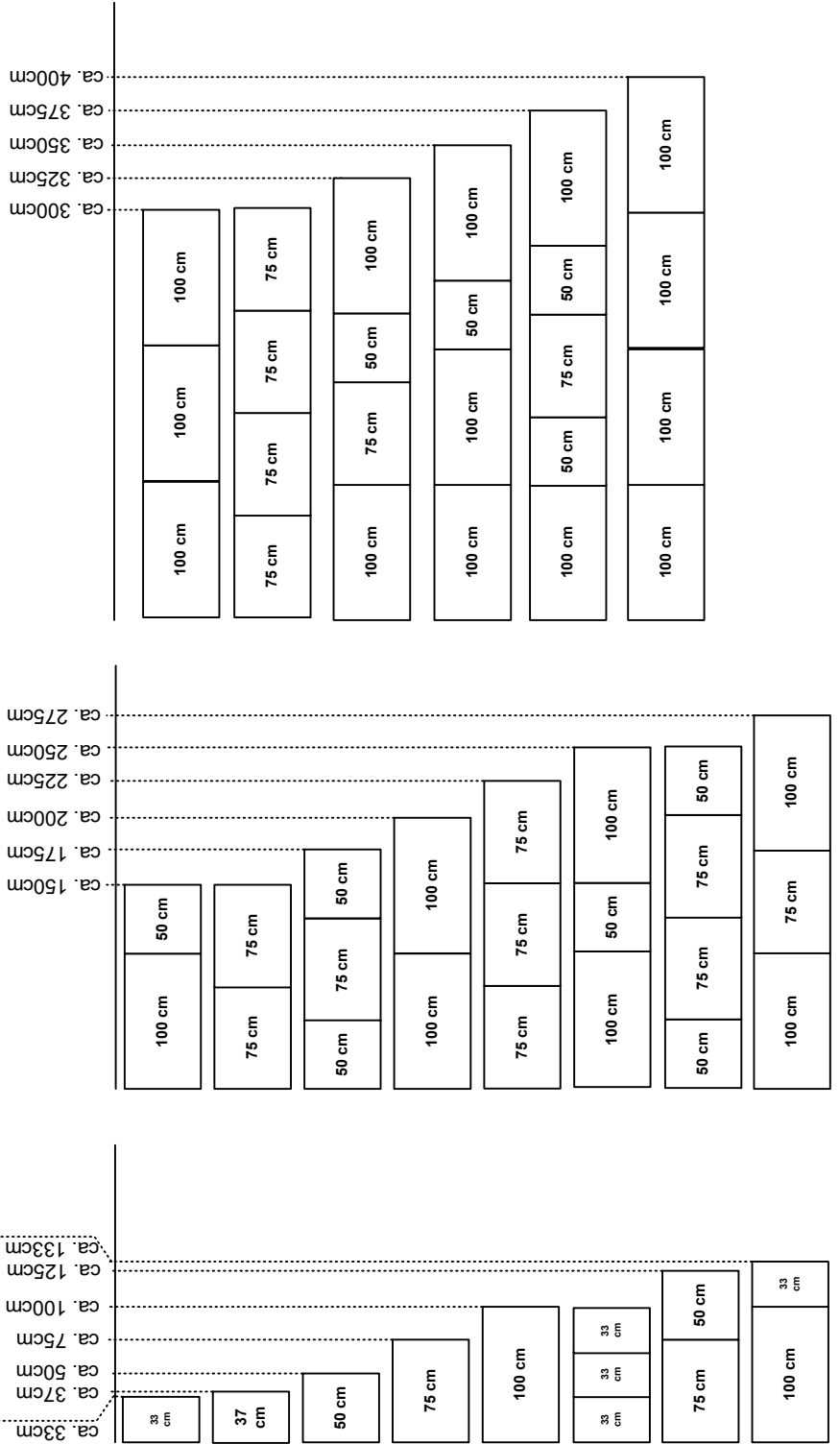

ca. 33 cm

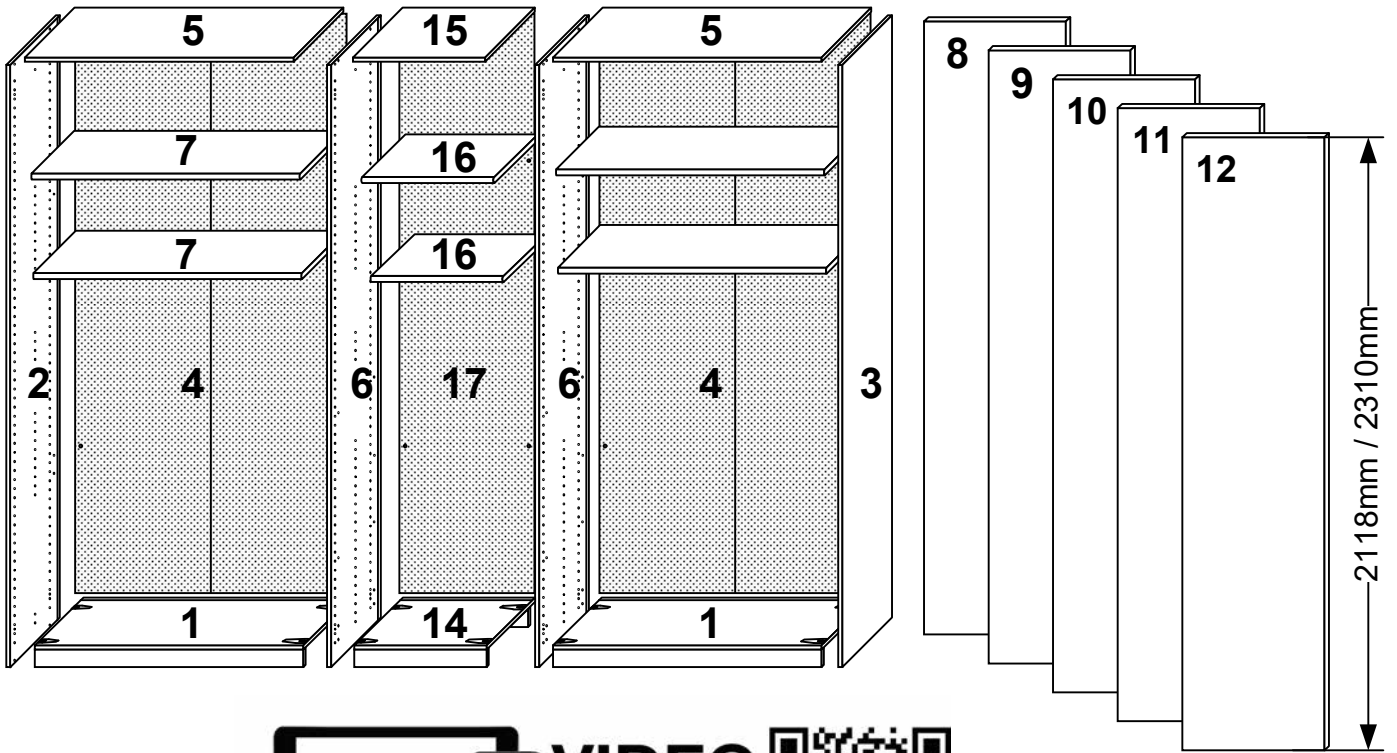



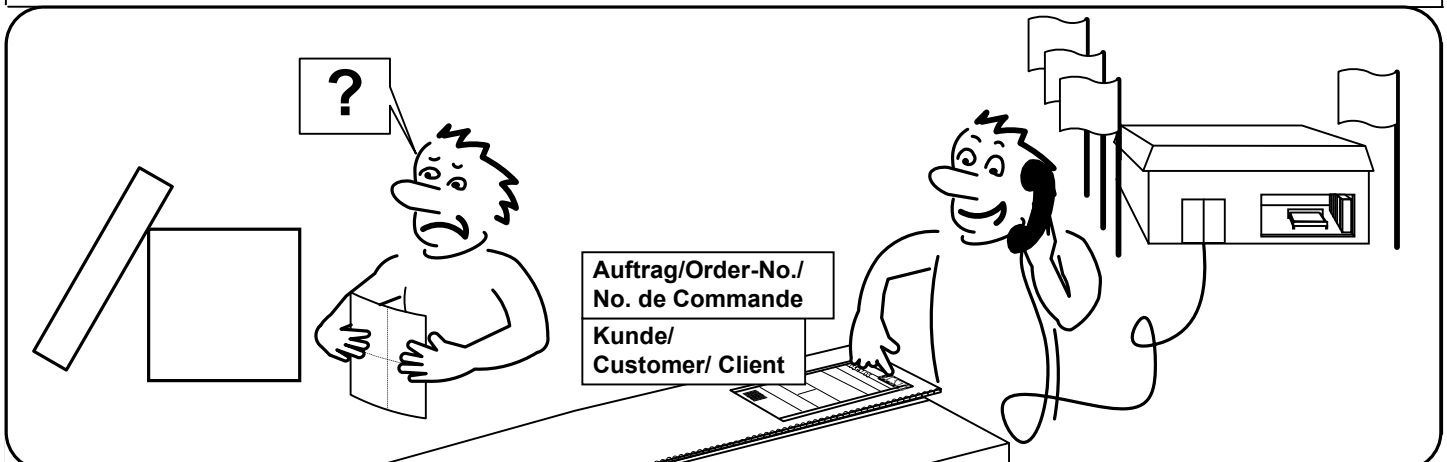

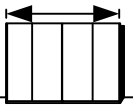
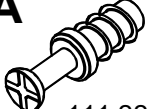
A 111 229	B 111 235	C 6,3x10,5 112 055	D 111 610	E 3,5x15 121 370	F 117 002	G 111 611
H 4,0x14 121 135	I 95,8 cm 117 035	J 71,6 cm 117 031	K 46,8 cm 117 036	L 29,5 cm 112 411	M 111 067	N 112 320
O D6 112321	P 34,6 cm 117 026					

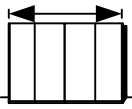
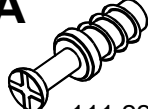

A		A  111 229	B  111 235
	ca. 33/35 cm	8 x	-
ca. 50 cm	8 x	-	
ca. 75 cm	8 x	-	
ca. 100 cm	8 x	-	
ca. 100 cm	8 x	8 x	
ca. 125 cm	8 x	4 x	
ca. 133 cm	8 x	8 x	
ca. 150 cm	8 x	4 x	
ca. 175 cm	8 x	8 x	

A		A  111 229	B  111 235
	ca. 200 cm	8 x	4 x
ca. 225 cm	8 x	8 x	
ca. 250 cm	8 x	8 x	
ca. 275 cm	8 x	8 x	
ca. 300 cm	8 x	8 x	
ca. 325 cm	8 x	12 x	
ca. 350 cm	8 x	12 x	
ca. 375 cm	8 x	16 x	
ca. 400 cm	8 x	12 x	

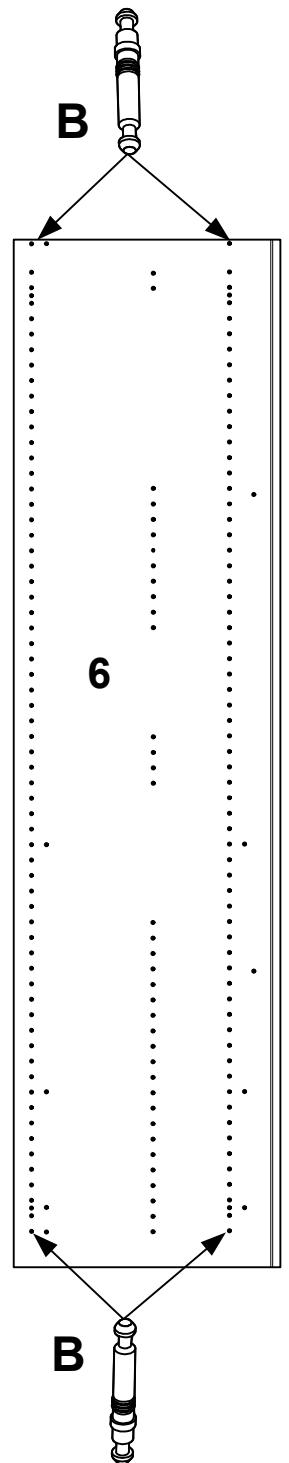
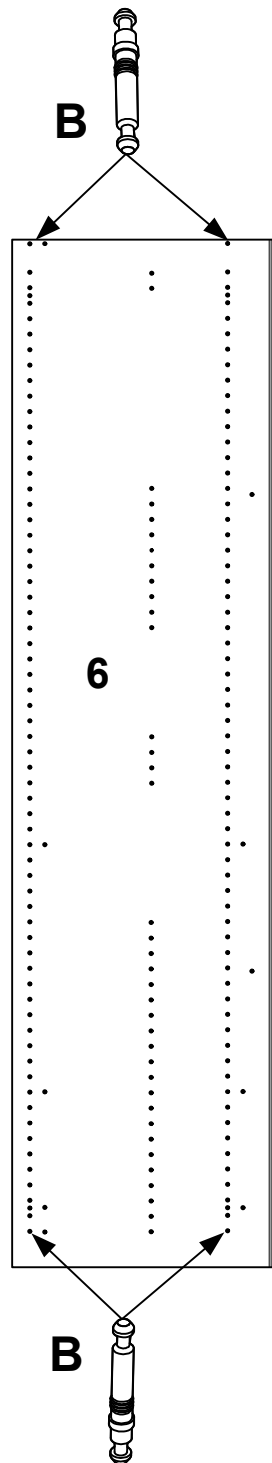
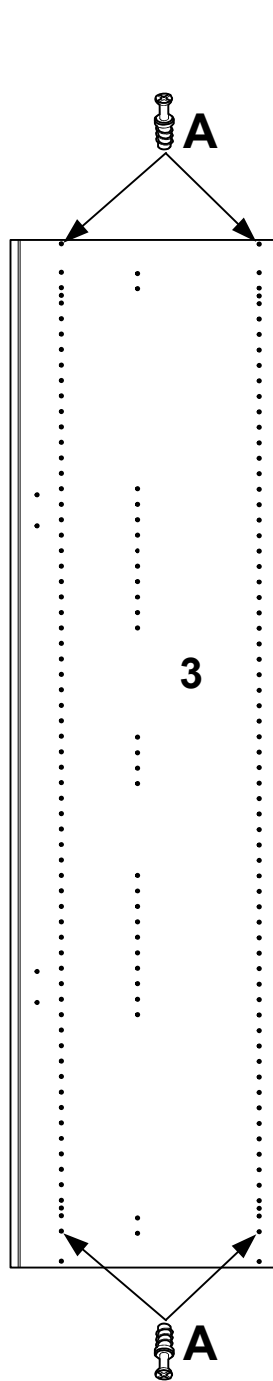
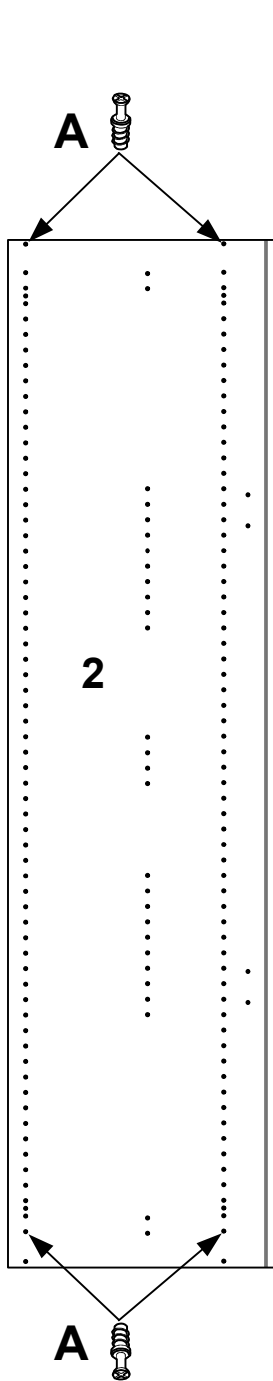

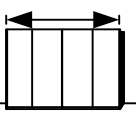
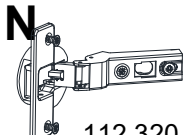
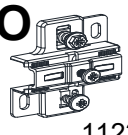
B		N  112 320	O  112321
			D6
ca. 33/35 cm	3-4 x	3-4 x	
ca. 50 cm	3-4 x	3-4 x	
ca. 75 cm	6-8 x	6-8 x	
ca. 100 cm	6-8 x	6-8 x	
ca. 100 cm	9-12 x	9-12 x	
ca. 125 cm	9-12 x	9-12 x	
ca. 133 cm	9-12 x	9-12 x	
ca. 150 cm	9-12 x	9-12 x	
ca. 175 cm	12-16 x	12-16 x	
ca. 200 cm	12-16 x	12-16 x	
ca. 225 cm	18-24 x	18-24 x	
ca. 250 cm	15-20 x	15-20 x	
ca. 275 cm	18-24 x	18-24 x	
ca. 300 cm	18-24 x	18-24 x	
ca. 325 cm	21-28 x	21-28 x	
ca. 350 cm	24-32 x	24-32 x	
ca. 375 cm	24-32 x	24-32 x	
ca. 400 cm	24-32 x	24-32 x	

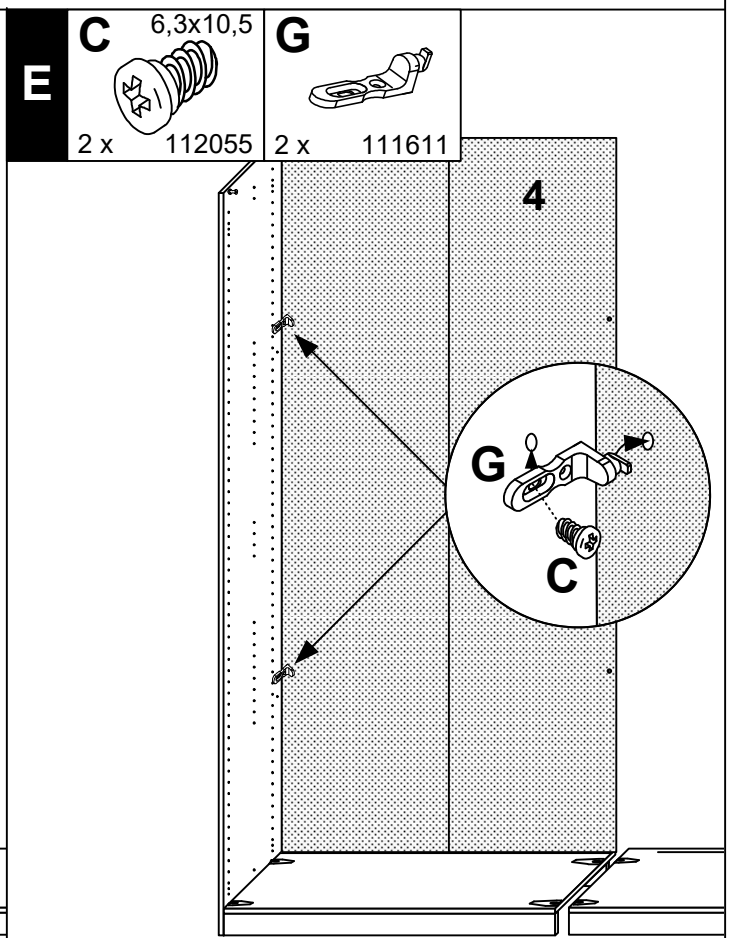
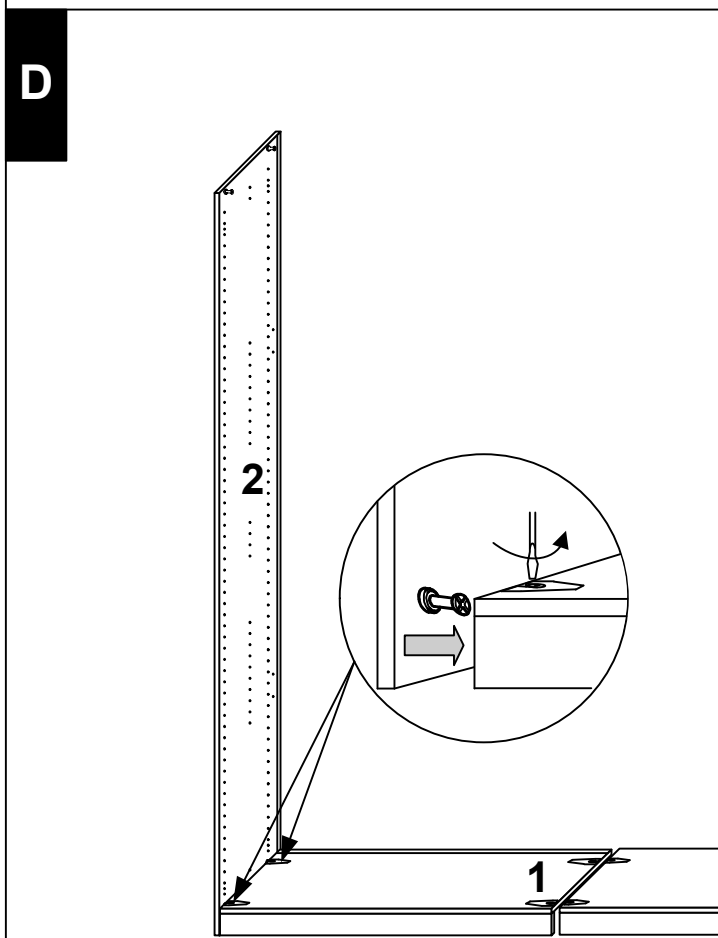
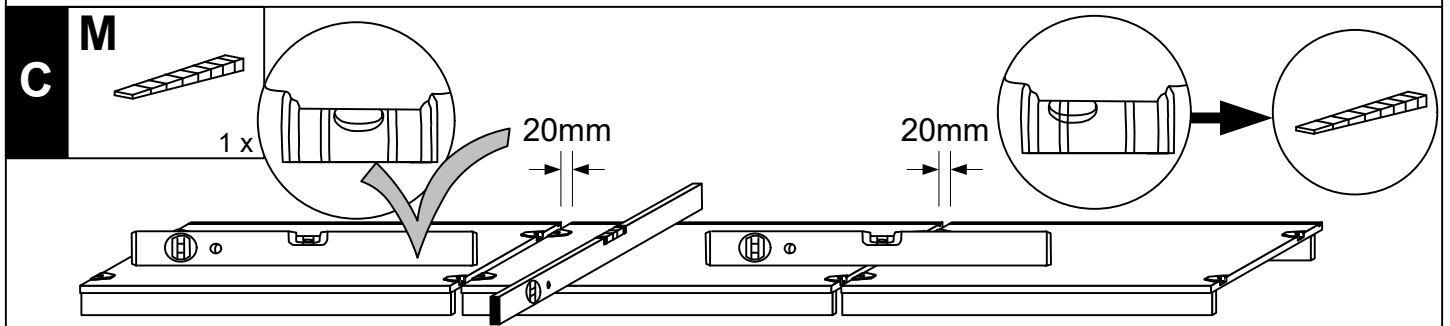
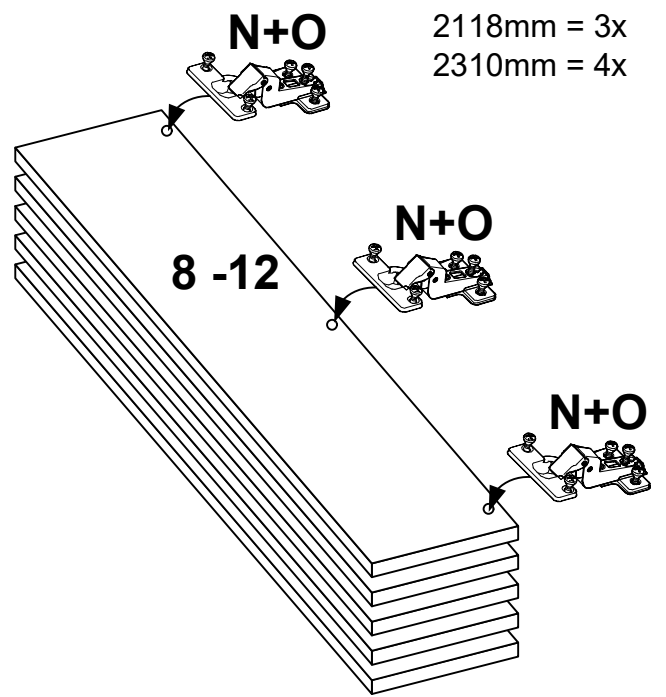

F	C 6,3x10,5	G
	2 x 112055	

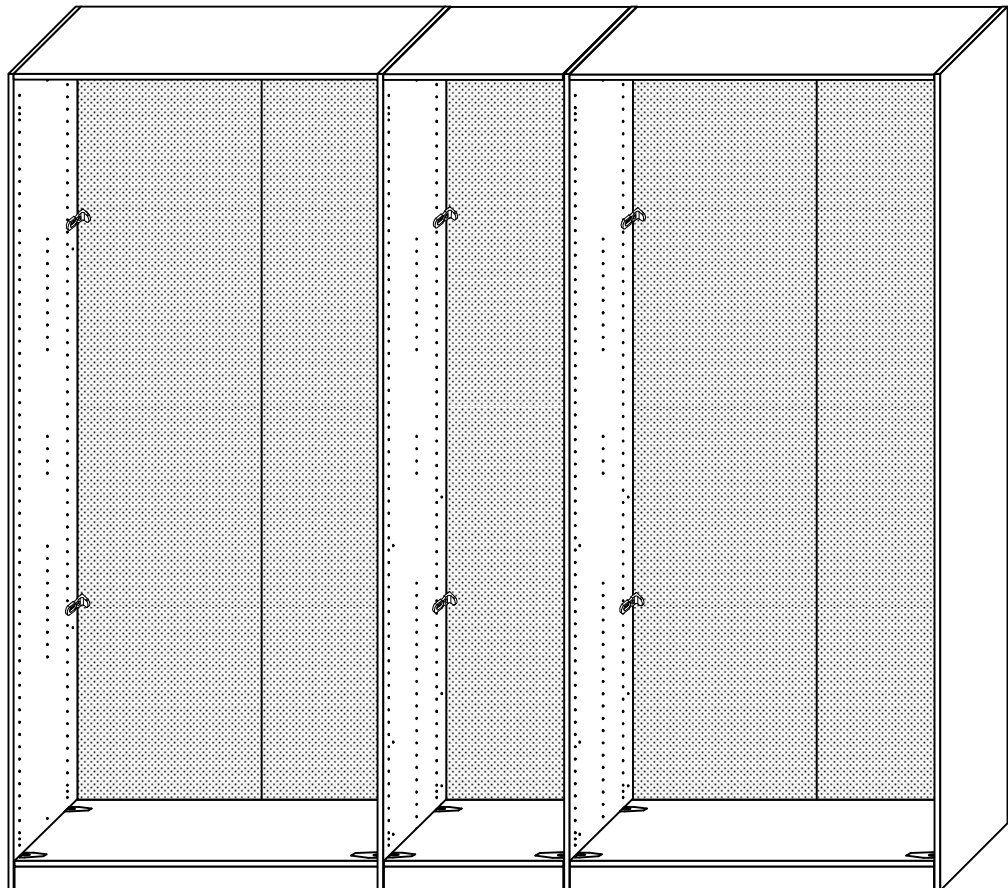
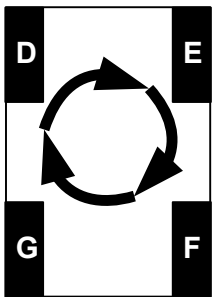
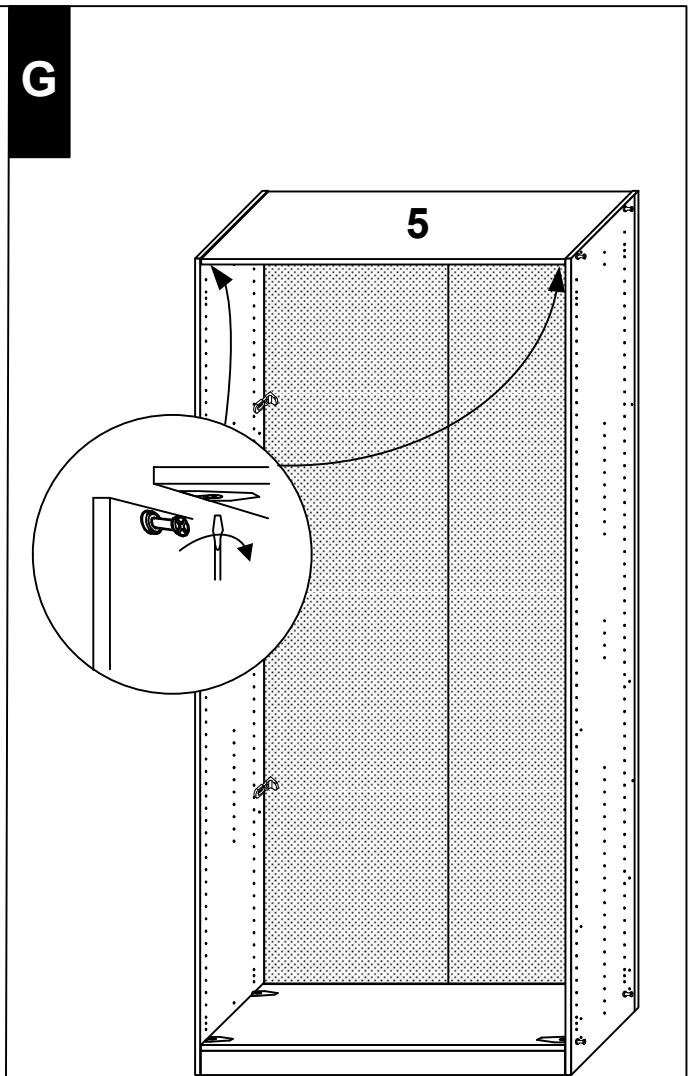
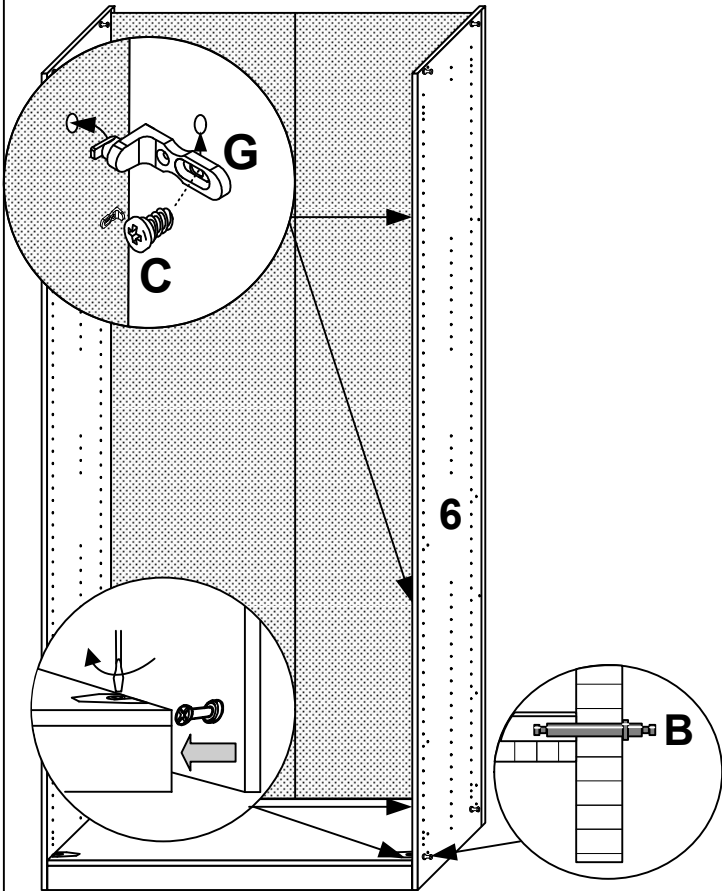

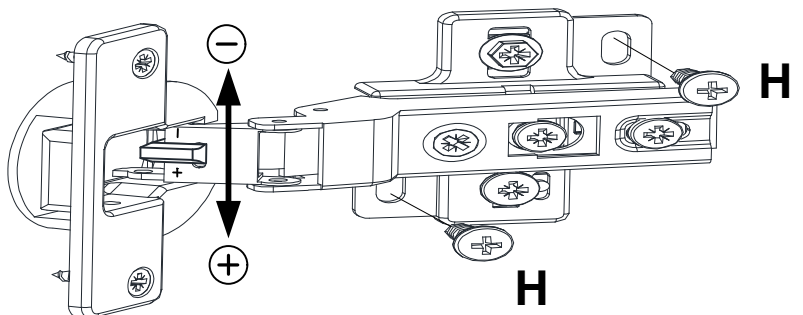
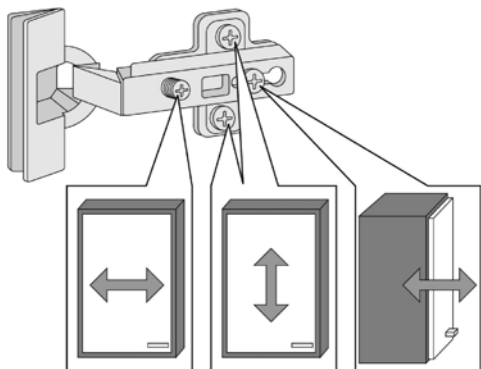
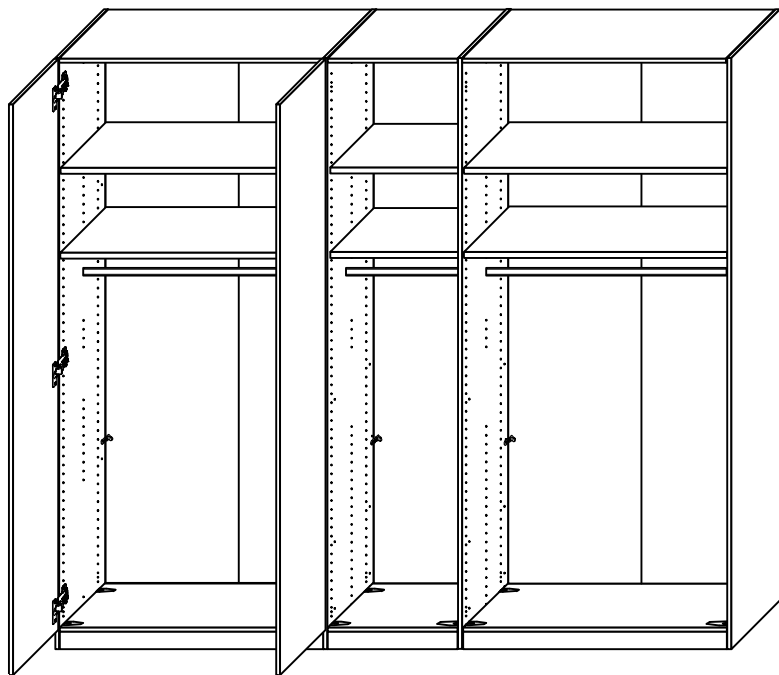
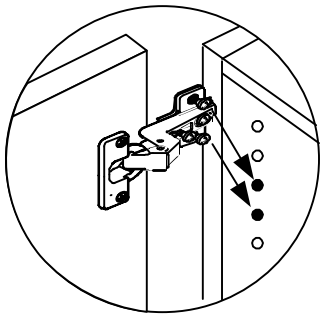
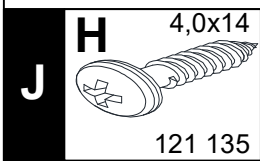
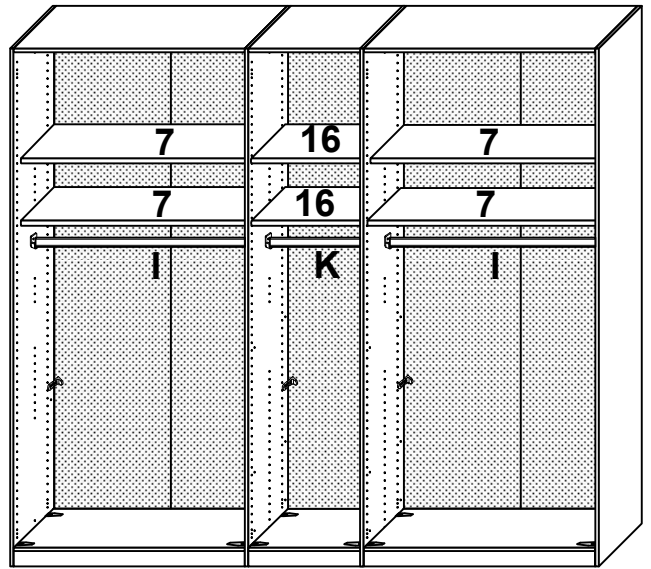
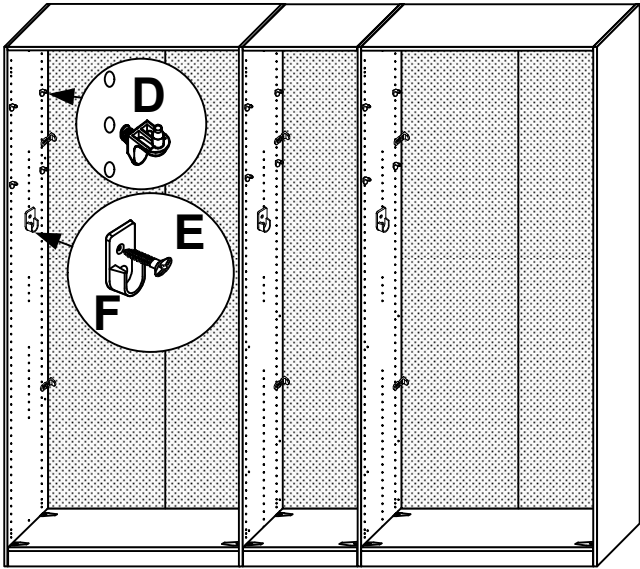
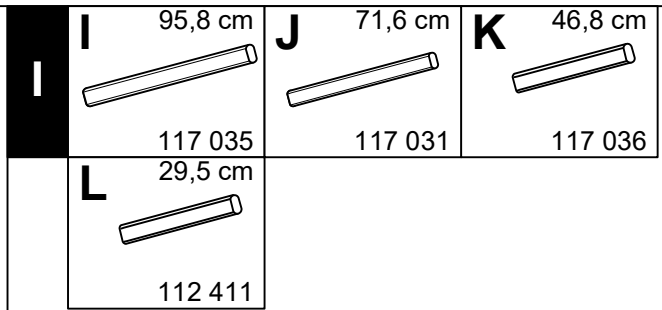
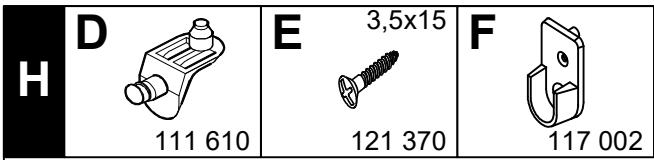

K **E** 3,5x15
2-10x 121370

